



OPERATING INSTRUCTIONS

INTEGRATED VOICE EVACUATION SYSTEM

VM-3000 Series

VOICE ALARM SYSTEM AMPLIFIER	VM-3240VA
VM EXTENSION AMPLIFIER	VM-3240E
FIREMAN'S MICROPHONE	RM-300MF
FIREMAN'S MICROPHONE EXTENSION	RM-320F
REMOTE MICROPHONE	RM-200M
REMOTE MICROPHONE EXTENSION	RM-210

Note: Refer to the Instruction Manual attached to the VX-2000DS for the installation of the the VX-2000DS Emergency power supply.

Thank you for purchasing TOA Integrated Voice Evacuation System VM-3000 Series.
Please carefully follow the instructions in this manual to ensure long, trouble-free use of your equipment.

TOA Corporation

TABLE OF CONTENTS

1. GENERAL DESCRIPTION	6
2. FEATURES	6
3. SYSTEM CONFIGURATION	
3.1. System Example 1	7
3.2. System Example 2	8
3.3. System Example 3	9
4. NOMENCLATURE AND FUNCTIONS	
4.1. VM-3240VA Voice Alarm System Amplifier	10
4.2. VM-3240E VM Extension Amplifier	10
4.3. RM-300MF Fireman's Microphone	16
4.4. RM-320F Fireman's Microphone Extension	19
4.5. RM-200M Remote Microphone	20
4.6. RM-210 Remote Microphone Extension	22
4.7. VP-2241 Power Amplifier	23
4.8. VP-200VX Power Amplifier Input Module	24
5. MAKING GENERAL BROADCASTS	
5.1. Making Broadcasts from the VM-3240VA	
5.1.1. BGM broadcasts	25
5.1.2. Microphone announcements	26
5.2. Broadcasting from the RM-200M	
5.2.1. Microphone announcements	28
5.2.2. Automatic announcement broadcasts	29
5.3. Making Automatic Announcements Using Control Signal Inputs	30
5.4. Summary of General Broadcast Procedures	
5.4.1. Making general broadcast from the VM-3240VA	31
5.4.2. Making general broadcasts from the RM-200M Remote Microphone ...	31
5.4.3. Broadcasting automatic general announcements using the control signal input	31
6. MAKING EMERGENCY BROADCASTS	32
6.1. Making Emergency Broadcasts from the VM-3240VA	
6.1.1. Microphone announcements	33
6.1.2. Automatic emergency announcement broadcasts	35
6.2. Making RM-300MF Emergency Broadcasts	
6.2.1. Microphone announcements	37
6.2.2. Automatic emergency announcement broadcasts	39
6.3. Making Automatic Emergency Announcements Using Control Signal Inputs (Automatic Fire Alarm Systems, etc.)	41
6.4. Summary of Emergency Broadcast Procedures	
6.4.1. Making emergency broadcast from the VM-3240VA	43
6.4.2. Fireman's microphone emergency broadcasts	43
6.4.3. Making automatic emergency announcements using the control signal input	43

7. EQUIPMENT STATUS AND RESPONSE WHEN EMERGENCY MODE IS ACTIVATED BY EXTERNAL EQUIPMENT	
7.1. RM-300MF Status and Operation When Emergency-Activated by External Equipment	44
7.2. VM-3240VA Status and Operation When Emergency-Activated by External Equipment	44
7.3. When Emergency-Activated by External Contact Input from Automatic Fire Alarm Systems, etc.	44
8. PRIORITY SETTINGS	
8.1. General Broadcast Priorities	45
8.2. Emergency Broadcast Priorities	46
9. CPU OFF FUNCTION	
9.1. What Is the CPU OFF Function?	47
9.2. Making All-Zone Calls Using the CPU OFF Function	
9.2.1. Making all-zone calls from the VM-3240VA	47
9.2.2. Making all-zone calls from the RM-300MF using the CPU OFF function	47
9.3. Priorities When All-Zone Calls Are Made Using the CPU OFF Function	48
10. SURVEILLANCE	
10.1. What Is the Surveillance Function?	49
10.2. How to Use the Surveillance Function	49
10.3. Monitored VM-3000 System Components	49
10.4. Equipment Operation upon Failure Detection and Recovery Procedure	50
10.4.1. Equipment operation upon failure detection	51
10.4.2. Failure acknowledgment	54
10.4.3. Failure reset operation	55
10.5. Examples of Failures and Their Counter-Operations	
10.5.1. Failure example 1: Communications failure	57
10.5.2. Failure example 2: Short circuit of speaker line 6	58
10.6. LCD Failure Display	60
11. SETTINGS	
11.1. Keys Used for Settings	64
11.2. Setting Hierarchical Chart	65
11.3. Configuration Settings	
11.3.1. Configuration settings hierarchical chart	66
11.3.2. Password entry	67
11.3.3. Configuration setting items	68
11.4. Information Settings	
11.4.1. Information setting hierarchical chart	77
11.4.2. Information setting items	77
11.5. Audio Settings	
11.5.1. Audio settings hierarchical chart	79
11.5.2. Audio setting items	80
11.6. Surveillance Settings	
11.6.1. Surveillance setting hierarchical chart	84
11.6.2. Surveillance setting items	84
11.7. Inputs 1 – 3 Settings	
11.7.1. Inputs 1 – 3 setting hierarchical chart	85
11.7.2. Inputs 1 – 3 setting items	86

11.8. BGM Settings	
11.8.1. BGM setting hierarchical chart	87
11.8.2. BGM setting items	88
12. REMOTE MICROPHONE SETTINGS (RM-300MF, RM-200M)	
12.1. DIP Switch Functions	
12.1.1. RM-300MF	89
12.1.2. RM-200M	89
12.2. Unit ID Number Settings	
(RM-300MF: Switch 5 operation or RM-200M: Switch 1 and 2 operation)	90
12.3. Compression Settings	
(RM-300MF: Switch 6 operation or RM-200M: Switch 6 operation)	90
12.4. Setting the Terminating RM-300MF Unit (RM-300MF: Switch 7 operation)	91
12.5. CPU OFF Function Enable/Disable Settings	
(RM-300MF: Switch 8 operation)	91
12.6. Talk Key Settings (RM-200M: Switch 4 operation)	91
12.7. Maintenance Mode (RM-300MF: Switch 1 operation)	91
13. INSTALLATION	
13.1. Installing the RM-300MF on a Wall	92
13.2. Installing the RM-320F on a Wall	95
13.3. Installing the RM-200M on a Wall	97
13.4. Installing the RM-210 on a Wall	98
13.5. Linking the RM-200M with the RM-210 (For Desktop Mounting)	99
13.6. Creating Remote Microphone Name Labels	
13.6.1. Inserting the name label	100
13.6.2. If the name label is not printed correctly	101
13.6.3. Dimensional diagram for printing devices	101
13.6.4. Pattern paper for hand writing	102
13.7. Installing the VP-200VX Power Amplifier Input Module	
in the VP-2241 Power Amplifier	104
13.8. Rack Mounting	106
13.9. Desktop Mounting of the VM Amplifiers	107
14. CONNECTIONS	
14.1. Removable Terminal Plug Connection	108
14.2. Audio and Control Connection Example	109
14.3. Remote Microphone Connections	
14.3.1. Power supply and limit on the number of remote microphones	110
14.3.2. RM-300MF connection	112
14.3.3. RM-200M connection	114
14.3.4. Connections between RM-300MF and RM-200M	116
14.4. General Control Input Terminal Connections	
14.4.1. Controlling functions assigned to the General Control	
Input terminals from the external equipment	117
14.4.2. Using the local input	118
14.4.3. Example of connection to external equipment	119
14.5. Emergency Control Input Terminal Connections	120
14.5.1. External emergency control equipment connection	121
14.5.2. Using the Amplifier cut off function	122
14.5.3. Connections to detect failures	
on the emergency control input lines	123
14.6. Status Output Terminal Connections	125

14.7. Power Amplifier and Speaker Connections	
14.7.1. Speaker connection	126
14.7.2. External attenuator connection (3-wire system)	126
14.7.3. External attenuator connection (4-wire system)	127
14.8. Connections between VM and VP Amplifiers	128
14.9. Connections between VM Amplifiers	130
14.10. Connecting Power Supply Equipment	131

15. VM-3000 CABLE USAGE TABLE..... 135

16. SPECIFICATIONS

16.1. VM-3240VA Voice Alarm System Amplifier	137
16.2. VM-3240E VM Extension Amplifier	139
16.3. RM-300MF Fireman's Microphone	140
16.4. RM-320F Fireman's Microphone Extension	140
16.5. RM-200M Remote Microphone	141
16.6. RM-210 Remote Microphone Extension	141
16.7. VP-2241 Power Amplifier 1 x 240 W	142
16.8. VP-200VX Power Amplifier Input Module	143
16.9. WB-RM200 WALL MOUNTING BRACKET	143

1. GENERAL DESCRIPTION

The VM-3000 Series Voice Alarm System is an integrated emergency/general announcement broadcast system. The VM-3240VA (240W) Voice Alarm System Amplifier plays the central role in the system. Using this amplifier in conjunction with the VM-3240E (240W) VM Extension Amplifiers allows larger systems to be built.

2. FEATURES

- The VM-3240VA has 6 speaker outputs. This can be expanded to up to 60 outputs by combining the VM-3240E amplifiers.
- Set data, log data and other Voice Alarm System Amplifier data can be accessed by way of the Ethernet.
- Up to 2 RM-300MF emergency broadcast Fireman's Microphones can be connected per Voice Alarm System Amplifier. Further, up to a total of 4 general broadcast-use RM-200M Remote Microphones and RM-300MF Fireman's Microphones can be connected.
- Connecting an external standby amplifier VP-2241 to both of the VM-3240VA amplifier and its Extension Amplifier VM-3240E enables background music (BGM)/paging broadcasts. The BGM/paging broadcast refers to simultaneous 2-channel broadcasts that allow paging calls (microphone announcements) to be made over other zones without interrupting current BGM broadcasts.
- For systems employing the VX-2000DS Emergency Power Supply, only emergency broadcasts can be made while backup power is being supplied by the VX-2000DS, even if the main power supply has been cut off.
- Easy-to-understand on-screen settings can be performed from a PC screen using the setting software.
- Audio inputs include inputs 1 – 4, a remote microphone input, an emergency remote microphone input, and BGM inputs 1 & 2 (select either of the two).
- Control inputs and outputs include 6 inputs and 3 status outputs for emergency broadcasts, and 8 inputs and 8 outputs for general broadcasts. By adding extension amplifiers (up to 9 units can be connected), the number can be increased up to 60 inputs for emergency broadcasts and up to 80 inputs and 80 outputs for general broadcasts.

3. SYSTEM CONFIGURATION

3.1. System Example 1

This example is for one of the simplest systems, and is ideal for installation in restaurants and small stores.

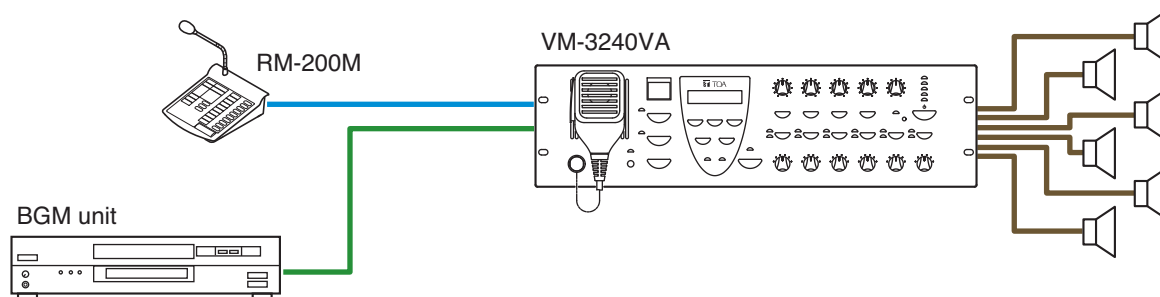

[System outline]

- A 240W 1-channel general broadcast system with 6 outputs.

3.2. System Example 2

A standby amplifier is connected to this system, which is ideal for installation in factories and schools.

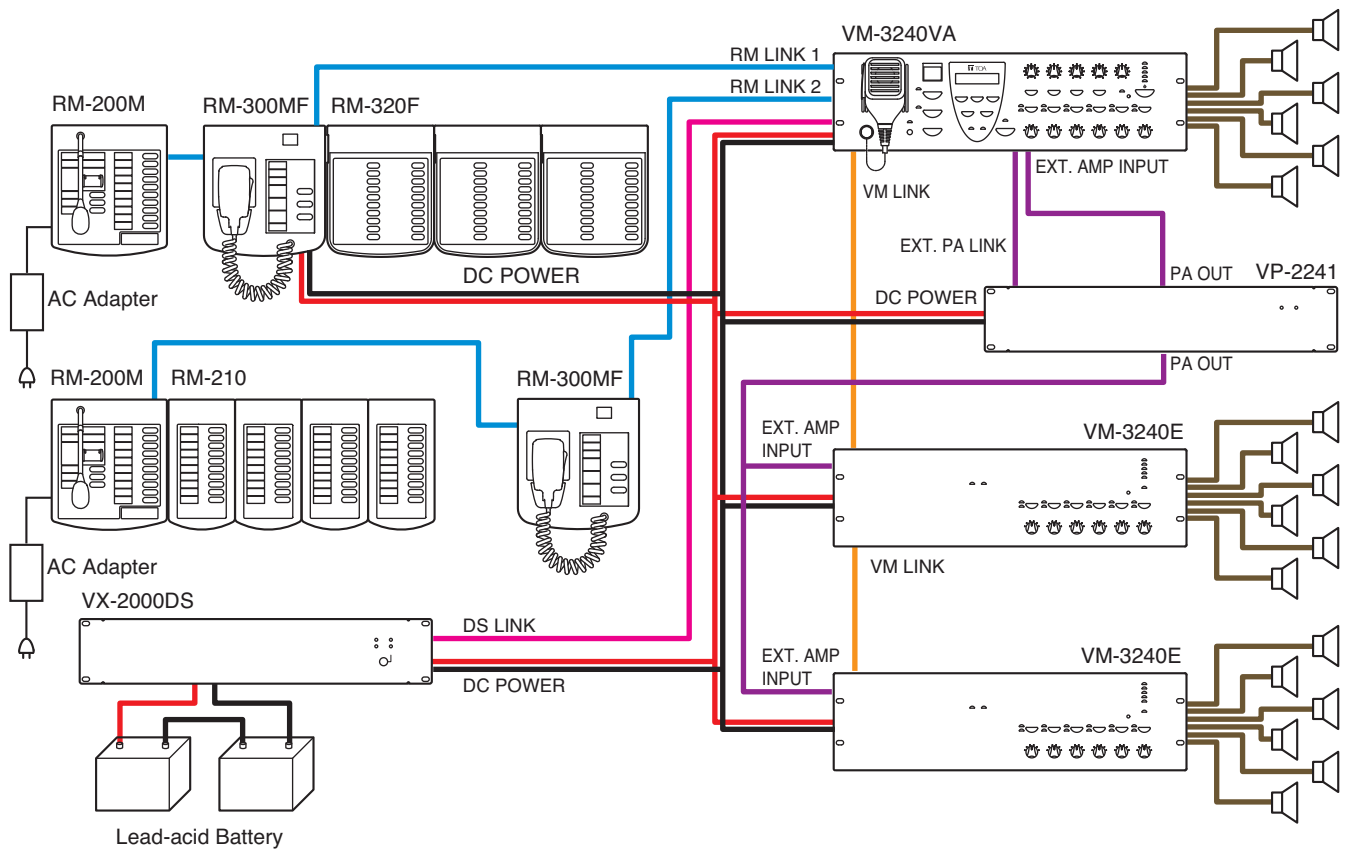

[System outline]

- A 720 W integrated 1-channel emergency/general broadcast system with 18 outputs.
- A VP-2241 standby amplifier is connected to the system. If the Voice Alarm System Amplifier should fail during a general or emergency broadcast, it is automatically switched to the standby amplifier, allowing the broadcast to continue uninterrupted.
- Emergency broadcasts can be made even during power failures if the VX-2000DS Emergency Power Supply is connected. However, general broadcasts are not possible.

3.3. System Example 3

This example is a system suited to shopping centers.

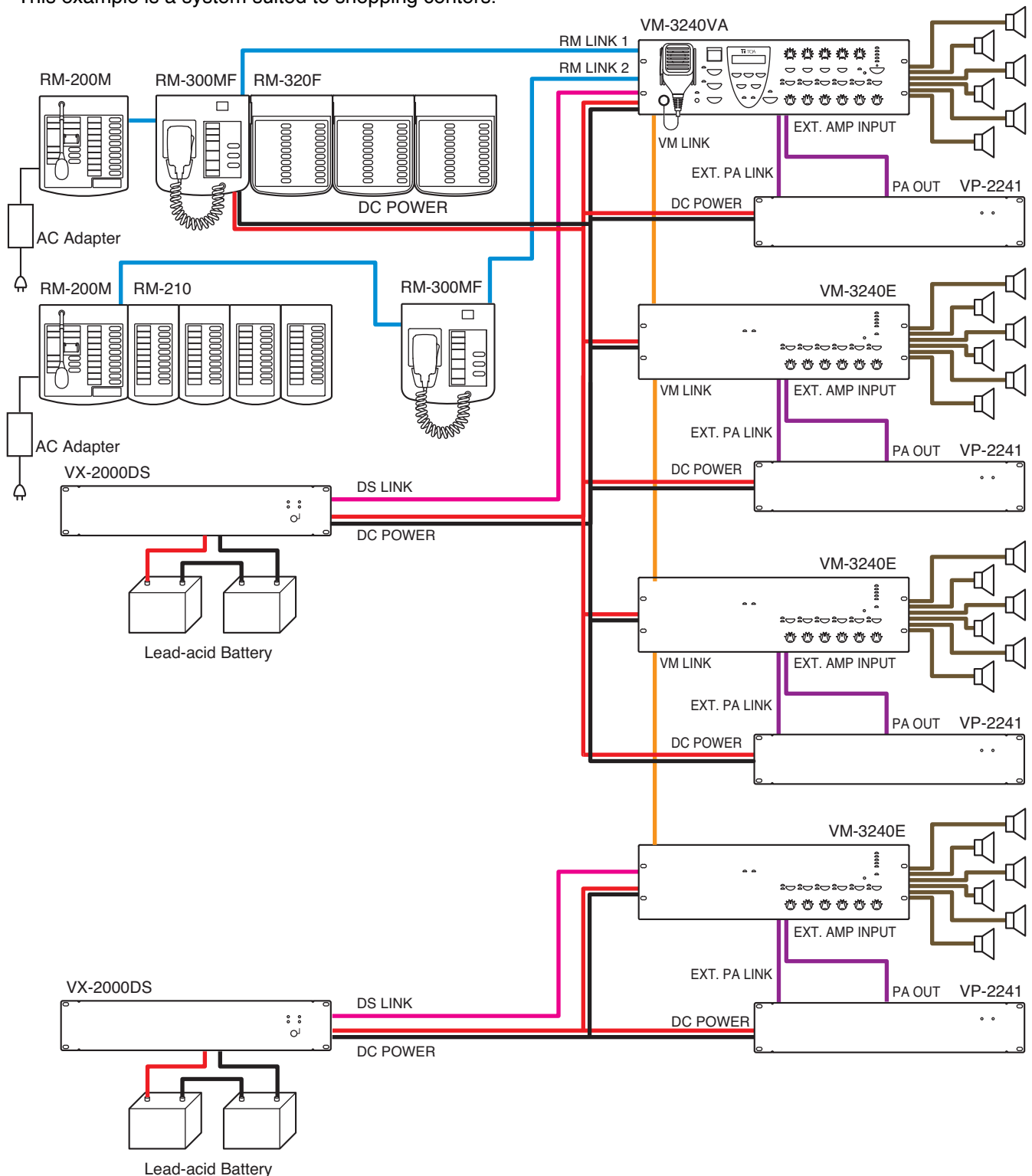

[System outline]

- In BGM/Paging system mode, the maximum output of each VM amplifier is 200 W.
- A 800 W integrated emergency/general broadcast system with 24 outputs.
- Unlike a 1-channel broadcast system, this system allows paging calls (microphone announcements) to be made over zones other than those currently being used by the BGM broadcast without interrupting the BGM broadcast. Example: It is possible to page over Zone 3 while playing BGM in Zones 1 and 2. BGM broadcasts are made by the VM amplifier and paging calls by the VP amplifier.
- Paging calls can still be initiated even if either the VM amplifier or the VP amplifier should fail.
- Emergency broadcasts can be made even if either the VM amplifier or the VP amplifier should fail.
- Emergency broadcasts can be made even during power failures if the VX-2000DS Emergency Power Supply is connected. However, general broadcasts are not possible.

4. NOMENCLATURE AND FUNCTIONS

4.1. VM-3240VA Voice Alarm System Amplifier

This amplifier functions as the central unit in the VM-3000 system and its power output is rated at 240 W. Only one unit can be connected in the system.

The front panel-mounted LCD displays setting and operation status. The amplifier also features an automatic message function and can play back up to 6 recorded general announcements and 2 recorded emergency announcements. Up to 2 RM-300MF Emergency Remote Fireman's Microphones can be connected, and up to a total of 4 RM-200M general broadcast-use Remote Microphones and RM-300MF Fireman's Microphones connected.

4.2. VM-3240E VM Extension Amplifiers

The system can be expanded by connecting up to 9 VM-3240E Extension Amplifiers. The 240 W VM-3240E is equipped with 6 speaker line outputs. It also features 8 inputs and 8 outputs for general broadcasts and 6 inputs and 3 outputs for emergency broadcasts. It is connected to the VM-3240VA via the VM Link connector.

[Front]

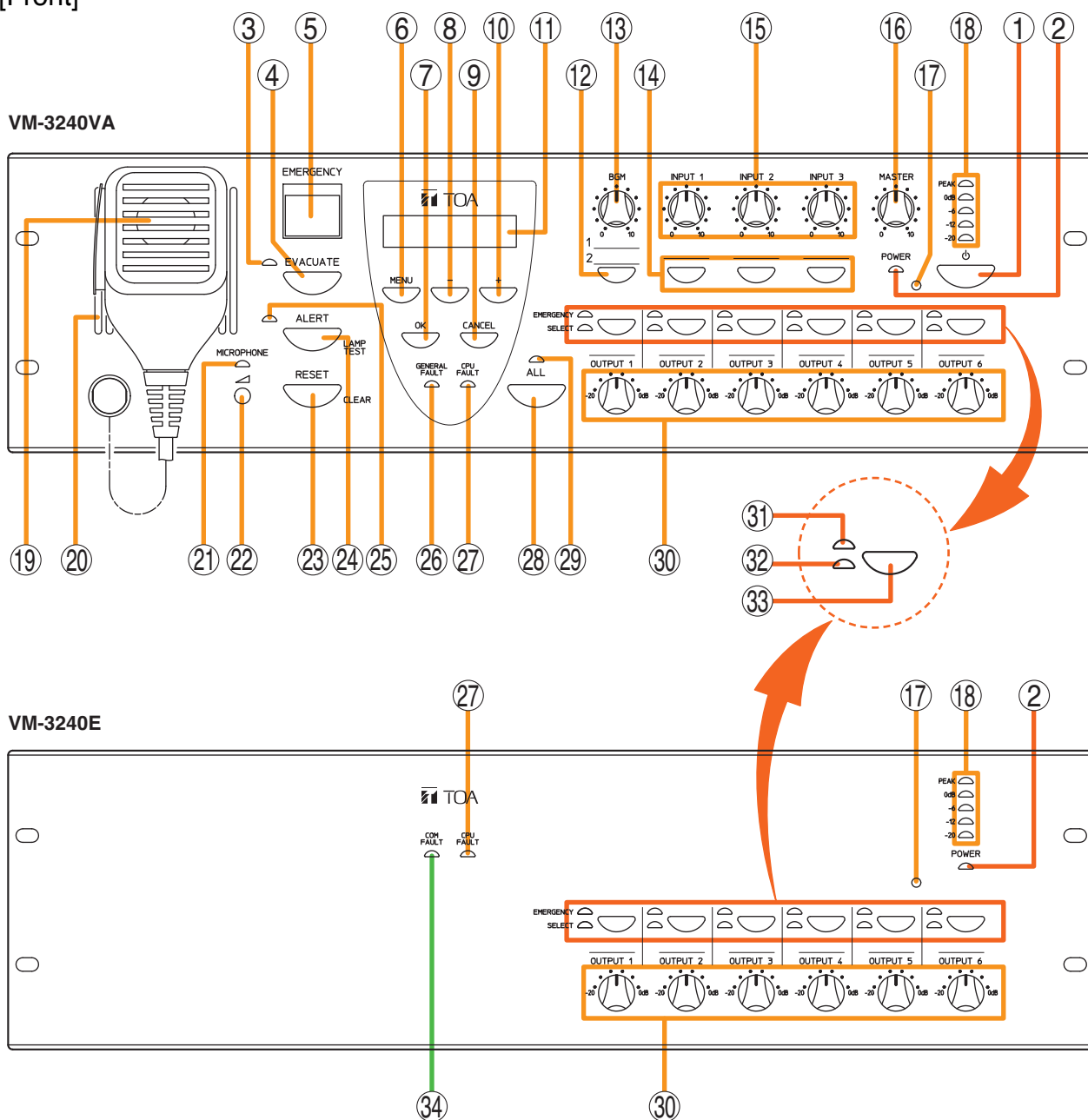

- Common to both Voice Alarm System and Extension amplifiers.
- Differing between Voice Alarm System and Extension amplifiers.

1. Power Switch

Unit is switched between operating and standby modes each time this switch is pressed. Power is always supplied regardless of the switch setting.

2. Live Status Indicator (green) [POWER]

Remains lit while power is supplied.

* As long as the power is connected, this indicator remains lit even if the power is switched OFF.

3. Evacuation Announcement Indicator (red)

Lights whenever an Evacuation announcement is broadcast.

4. Evacuation Announcement Key [EVACUATE]

Can only be used while in emergency broadcast mode.

Pressing this key plays back the recorded Evacuation announcement, which is broadcast from the speaker output(s) selected with the Output Selection key (33). To stop an Evacuation announcement, hold down this key for 3 seconds or more during emergency broadcast.

5. Emergency Activation Switch / Emergency Indicator (red) [EMERGENCY]

Pressing this switch while it is unlit causes it to light while switching output to emergency broadcast mode. (No automatic announcements are made.)

When an emergency broadcast is activated by a control input other than this switch or by the Fireman's Microphone, the switch flashes and a buzzer sounds, disabling front panel operation.

While flashing, this switch functions as an emergency activation acknowledgement switch. Pressing this switch while it is flashing causes it to stay lit, stopping the buzzer and enabling front panel operation. In any case, this switch goes out once the emergency broadcast is reset.

Steady ON: Lights when the emergency mode is activated either by this switch or by other connected external equipment and subsequently acknowledged, and remains lit until the emergency mode is reset.

Flashing: Flashes when the emergency mode is activated by external equipment other than this switch.

6. Menu Key [MENU]

During emergency broadcasts:

Cannot be used.

During general broadcasts:

Displays the setting item menu.

During settings:

Selects the setting item.

7. OK Key [OK]

During failure indication:

Stops the buzzer when a failure is detected by the surveillance function (functioning as a failure acknowledgment key).*

During setting:

Functions as a confirmation key.

* For more information on surveillance functions, refer to [page 49](#).

8. – (Minus) Key [–]

Decreases setting value numbers.

9. Cancel Key [CANCEL]

Returns the display to the previous screen during settings.

Pressing this switch when a failure occurs reverts the unit back to normal mode. (Refer to "[Failure reset operation](#)" on [page 55](#) and "[Examples of Failures and Their Counter-Operations](#)" on [page 57](#).)

10. + (Plus) Key [+]

Increases setting value numbers.

11. LCD

Backlit during unit operation.

During emergency or general broadcasts:

Displays operation and failure information.

During settings:

Used to perform settings.

12. BGM Selection Key [BGM]

Displays the BGM (background music) selection screen on the LCD (11). The display switches between the setting screens for Treble, Bass, etc. with each depression of this key. (Refer to "[BGM Settings](#)" on [page 87](#).)

13. BGM Volume Control [BGM]

Adjusts the BGM input volume.

14. Input Selection Keys [INPUT 1 – 3]

Display key's corresponding setting screen on the LCD (11). The display switches between the setting screens for Treble, Bass, etc. with each depression of the selected key. (Refer to "[Input 1 – 3 Settings](#)" on [page 85](#).)

15. Input Volume Controls [INPUT 1 – 3]

Adjust the input volume for Inputs 1 – 3.

16. Master Volume Control [MASTER]

Sets the output volume for the entire system.

- 17. VM Reset Key**
For the VM-3240VA:
 Resets the entire system.
For the VM-3240E:
 Resets only VM-3240E Extension amplifiers.
- 18. Level Meter**
 Indicates the output level of the unit's internal amplifier.
- 19. Emergency Microphone**
 Only used while in emergency broadcast mode. Press the Talk key located on the side of the microphone to broadcast emergency announcements.
- 20. Monitor Speaker**
 Buzzer tone is audible from this speaker when the emergency mode is activated by external equipment other than the unit's Emergency Activation switch (5) or when any failure occurs.
- 21. Emergency Microphone Indicator (red)**
 Lights when the unit's front panel-mounted emergency microphone (19) is used.
- 22. Emergency Microphone Volume Control**
 Rotate clockwise to increase the emergency microphone volume.
 Rotate counterclockwise to decrease the emergency microphone volume.
- 23. Reset Key [RESET]**
For emergency broadcasts:
 Terminates the emergency broadcast and returns operation to the original general broadcast.
For general broadcasts:
 Resets the front panel's output selection status.
- 24. Alert Announcement Start Key [ALERT]**
For emergency broadcasts:
 Plays recorded Alert announcements through the speaker output selected with the Output Selection key (33). Holding down this key for 3 seconds stops the broadcast.
For general broadcasts:
 Used to test LED indicators. (While pressed, LED indicators remain lit and the unit's internal buzzer sounds.)
- 25. Alert Announcement Indicator (red)**
 Remains lit while a recorded Alert announcement is being broadcast.
- 26. Failure Indicator (yellow) [GENERAL FAULT] (VM-3240VA only)**
 Flashes when a failure occurs while sounding the internal buzzer. Pressing the [OK] key (7) stops the buzzer and switches the indicator from flashing to steady ON. Failure details are displayed on the LCD (11). (When there are multiple failures, they can be checked by moving the screen using the [+] key (10) or [-] key (8)). Failures are not displayed on the LCD when in setting mode. Failures are displayed or notified after exiting the setting mode. Also, if any failure occurs during general or emergency broadcasts, the operation status and failure display are alternately shown on the LCD.
- 27. CPU Failure Indicator (yellow) [CPU FAULT]**
 Lights when the CPU fails.
- 28. All-Zone Call Selection Key [ALL]**
 Simultaneously selects all speaker outputs for general and emergency broadcasts. Press again to reset the simultaneous selection.
 When pressed, all speaker output volume controls do not work in both general and emergency broadcast modes.
- 29. All-Zone Call Indicator (green) [ALL]**
 Lights when an all-zone call is initiated.
- 30. Speaker Output Volume Controls [OUTPUT 1 – 6]**
 Adjust the output volume of speaker outputs 1 – 6.
- 31. Emergency Broadcast Output Indicators (red) [EMERGENCY]**
 Indicate the speaker outputs for emergency broadcasts.
- 32. Selected Output Indicators (green) [SELECT]**
 Indicate the speaker outputs selected with the Output Selection key (33).
- 33. Output Selection Keys**
 Select corresponding speaker output. Press again to reset the selection.
For general broadcasts:
 Select and reset broadcast zones.
For emergency broadcast:
 Select and reset speaker outputs for emergency broadcasts made by the unit's front panel-mounted emergency microphone and automatic announcements.
- 34. Communications Failure Indicator (yellow) [COM FAULT] (VM-3240E only)**
 Flashes when failures are detected in communications with the VM-3240VA.

[Rear]

VM-3240VA

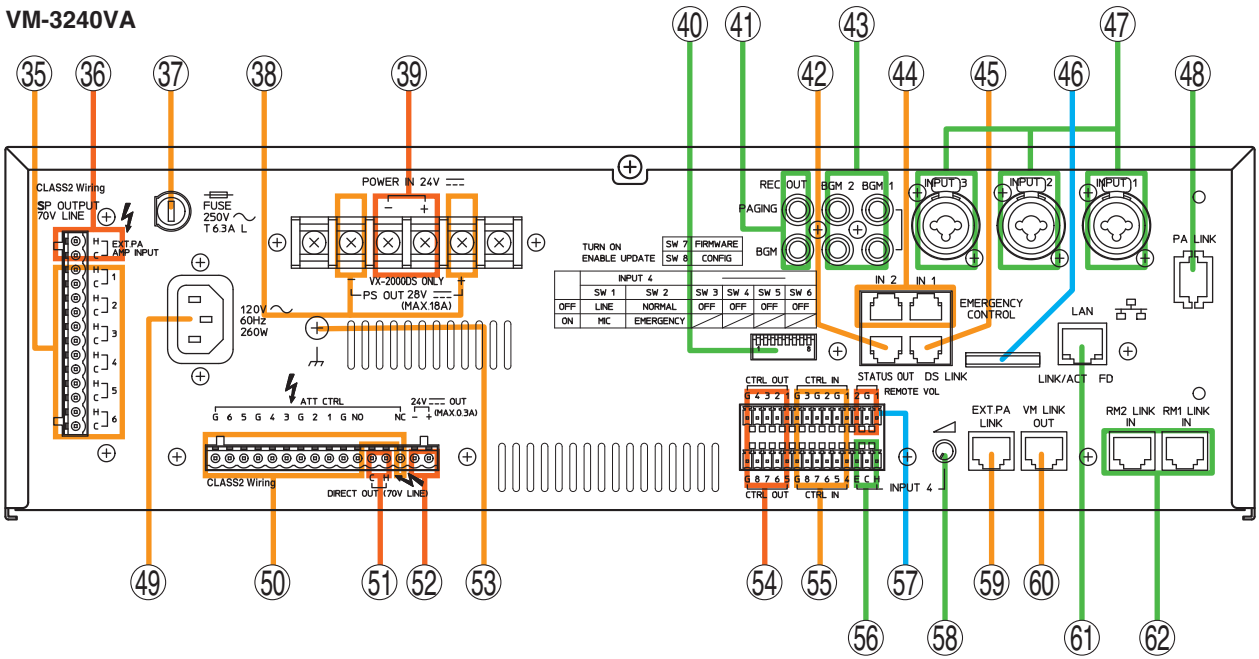

VM-3240E

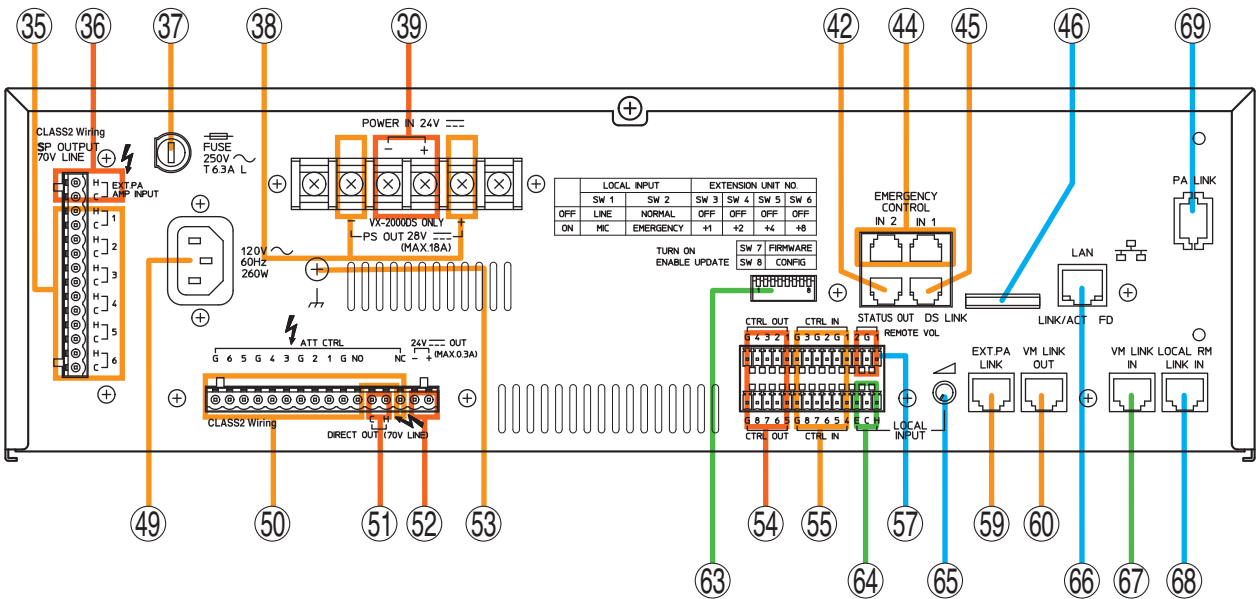

- Common to both Voice Alarm System and Extension amplifiers.
- Differing between Voice Alarm System and Extension amplifiers.
- Not used.

35. Speaker Output Terminals 1 – 6 [SP OUT 70 V LINE 1-6, H, C]
Connect speakers to these outputs.

37. AC Fuse
Use the following 20 mm type miniature fuses:
8 A (for VM-3240VA and VM-3240E)

36. External Amplifier Input [EXT. PA AMP INPUT]
Audio input terminals for VP-2241 standby amplifier's PA OUT terminals (70 V line).

38. Power Supply Output Terminals [VX-2000DS ONLY, PS OUT]
Supply power to the VX-2000DS Emergency Power Supply. When the VX-2000DS is not connected, use shorting bars to connect PS OUT (+) to POWER IN (+) and PS OUT (-) to POWER IN (-).

39. 24 V DC Input Terminals [VX-2000DS ONLY, 24 V POWER IN]

Connect power from the VX-2000DS Emergency Power Supply Unit. When the VX-2000DS is not connected, use shorting bars to connect PS OUT (+) to DC POWER IN (+) and PS OUT (-) to DC POWER IN (-).

40. DIP switch (VM-3240VA only)

Used to perform equipment settings.

DIP Switch 1 [LINE/MIC]

Switches input sensitivity of Input 4. (ON: MIC, OFF: LINE; Default: OFF)

DIP Switch 2 [NORMAL/EMERGENCY]

Always set this switch to OFF. (Default: OFF)

DIP Switches 3 – 5

Not used. (Default: OFF)

DIP Switches 6

Set to ON when excluding the front-mounted emergency microphone from the surveillance item. (Default: OFF)

DIP Switch 7 [FIRMWARE]

Set to ON when upgrading firmware version, and OFF to prohibit update. (Default: ON)

DIP Switch 8 [CONFIG]

Set to ON when transferring set data from a PC, and to OFF to prohibit set data transfer. (Default: ON) (For more information on set data transfer, refer to "Transferring Data Edited by PC between the VM-3000VA and a PC" in the separate software manual.)

41. BGM/Paging Recording Output Terminals [REC OUT BGM/PAGING]

(VM-3240VA only)

Output BGM and Paging bus audio signals.

42. Status Output Terminals [STATUS OUT]

Provide the following status outputs in synchronization with unit operation:

- Emergency status output
- Failure status output
- CPU OFF status output

43. BGM 1 & 2 Input Terminals [BGM 1, 2] (VM-3240VA only)

Connect the BGM sound source.

(-10 dB*, 10 kΩ)

*0 dB = 1 V

44. Emergency Control Input Terminals 1 – 6 [EMERGENCY CONTROL, IN 1/IN 2]

Connect to an automatic fire alarm system and activate emergency broadcasts, play back/stop automatic emergency announcements and reset emergency broadcasts.

Contact inputs 1 - 5 are no-voltage make contact inputs.

Input 6 is an isolated voltage input which activates when the polarity of the applied voltage (24 V DC is kept applied to this terminal under normal condition) is reversed.

45. DS Link Connector [DS LINK]

Connects to the VX-2000DS Emergency Power Supply's DS-SF link connector.

46. Not used.

47. Audio Input Terminals 1 – 3 [INPUT 1 – 3] (VM-3240VA only)

Electronically-balanced 600 Ω, -10 dB* / -50 dB, XLR/phone jack combination connectors. LINE or MIC input can be selected, and the phantom power supply turned on and off. (Refer to "Inputs 1-3 Settings" on page 85.) These inputs can be converted into transformer-balanced terminals using the optional IT-450 transformer. It is also possible to change microphone sensitivity to -30 dB. (Refer to the separate Installation guide.)

* 0 dB = 1 V

48. PA Link Connector [PA LINK]

Not used.

49. AC Input

Connects to an AC outlet using the supplied AC power cord.

50. Attenuator Control Outputs [ATT CTRL]

Connect to external attenuators.

51. Direct Output Terminals [DIRECT OUT 70 V LINE]

These speaker output terminals (70 V line) provide direct output of paging calls.

52. 24 V DC Output [24 V, +, -]

Provide 24 V DC output, max. 0.3 A.

53. Functional Ground Terminal

Hum noise may be generated when external equipment is connected to the unit. Connecting this terminal to the functional ground terminal of the external equipment may reduce the hum noise.

Note: This ground is not for protective ground.

54. Control Output Terminals 1 – 8 [CTRL OUT 1 – 8, G]

Control output terminals for general broadcasts. Operations assigned to each contact output are determined by software settings. (For details, refer to "Event Settings" in the separate software manual.)

55. Control Input Terminals 1 – 8 [CTRL IN 1 – 8, G]

Control input terminals for general broadcasts. Functions assigned to each contact input are determined by software settings. (For details, refer to "Event Settings" in the separate software manual.)

56. Audio Input 4 Terminals [INPUT 4] (VM-3240VA only)

Electronically-balanced 600 Ω , -10 dB* / -50 dB, screw terminal. Use DIP switch (40) for LINE/MIC switching.
* 0 dB = 1 V

57. Remote VOL Terminals 1 & 2 [REMOTE VOL]

Not used.

58. Input 4 Volume Control (VM-3240VA only)

Adjusts the audio input terminal 4's (56) input volume.

59. External Amplifier Link Connector [EXT. PA LINK]

Connects to the VP-2241 standby amplifier's PA Link connector.

60. VM Link Connector [VM Link Out]

Connects to the VM-3240E's VM Link In connector.

61. LAN Connector [LAN] (VM-3240VA only)

Connects to a PC.

62. Remote Microphone Link Connectors 1 & 2 [RM1 LINK IN, RM2 LINK IN] (VM-3240VA only)

Connect the RM-300MF Fireman's Microphone or RM-200M Remote Microphone to these connectors.

63. DIP Switch (VM-3240E only)

Used for unit ID and equipment settings.

DIP Switches 1 & 2 [LOCAL INPUT]

Not used. Default setting: OFF

DIP Switches 3 – 6 [EXTENSION UNIT NO.]

Used for unit ID settings for the VM-3240E. (Refer to "[Connections between VM Amplifiers](#)" on page 130 for ID settings.)

Default settings: ON (Switch 3), OFF (Switches 4 – 6)

DIP Switch 7 [FIRMWARE]

Set this switch to ON to enable firmware version updates, and OFF to prohibit the update.

Default setting: ON

DIP Switch 8 [CONFIG]

Not used.

Default setting: ON

64. Local Input Terminals [LOCAL INPUT] (VM-3240E only)

Local broadcast can be made when this terminal is used in conjunction with the Control Input terminals (55).

For details, refer to "6. SYSTEM SETTINGS; 6.8. Local Input Setting" in the separate software instruction manual.).

65. Local Input Volume Control

(VM-3240E only)

Adjusts the input volume of the equipment connected to the Local Input terminal (64).

66. LAN Connector [LAN]

(VM-3240E only)

Not used.

67. VM Link In Connector [VM LINK IN]

(VM-3240E only)

Connect this connector to the VM-3240VA's VM LINK OUT connector. When using two or more VM-3240Es, connect this connector to other VM-3240E's VM LINK OUT.

68. Local Remote Microphone Link Connector [LOCAL RM LINK IN] (VM-3240E only)

(VM-3240E only)

Not used.

69. PA Link Connector [PA LINK]

Not used.

4.3. RM-300MF Fireman's Microphone

This microphone is designed to be used exclusively for emergency broadcasts made by firemen or other persons when instructing building occupants to evacuate in emergency situations. It can activate the emergency mode, start and stop automatic broadcasts of emergency announcements, reset emergency signals, and make live microphone announcements in emergency situations. Operating the microphone's CPU OFF switch allows all-zone calls (simultaneous attenuator-free global calls) to go through. No general broadcasts can be made. By connecting the RM-320F Fireman's Microphone Extension to the RM-300MF Fireman's Microphone, the zone selection or failure indication/failure acknowledgment/failure reset function can be enabled. Up to 3 RM-320Fs can be connected to the Fireman's Microphone, expanding the available keys up to 20 per unit.

[Top]

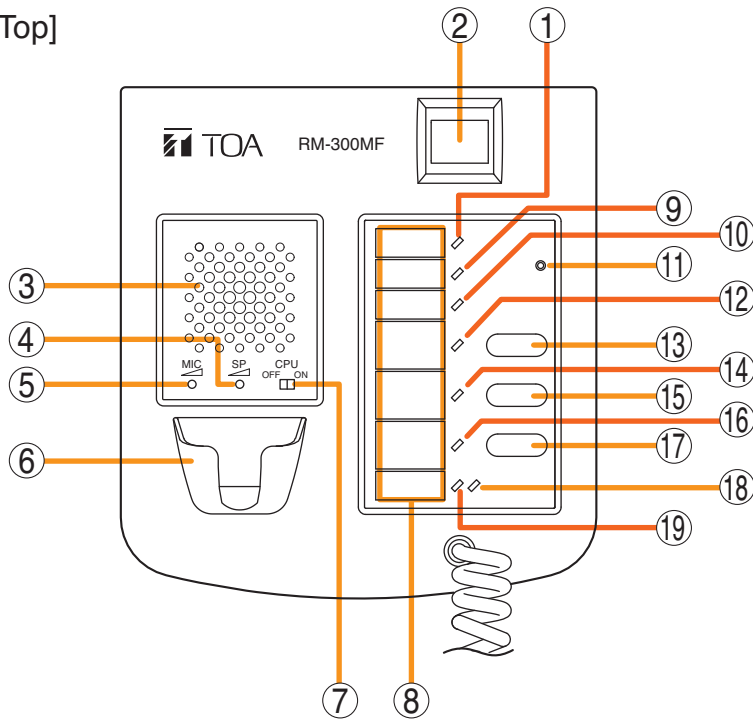

[Side]

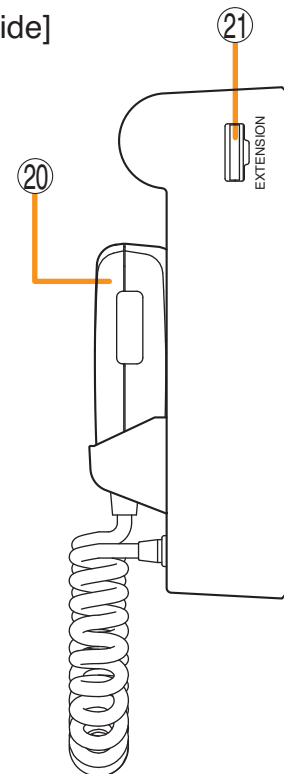

[Bottom]

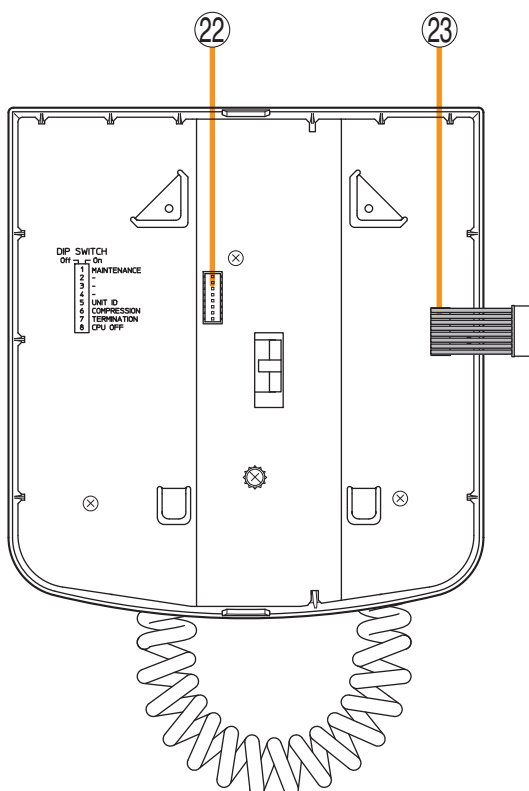

[Wall mount bracket unit (accessory)]

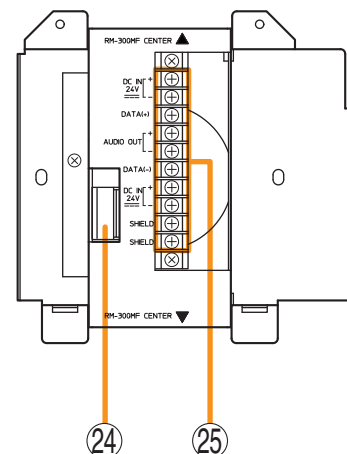

1. Power Indicator (green)

Lights when power is supplied to the unit.

2. Emergency Activation Switch/Emergency Indicator (red)

Places the system in emergency mode while illuminated. Also flashes when the emergency mode is activated by external equipment. In this event, if the switch is pressed to acknowledge the emergency activation, it changes from flashing to steady ON mode.

3. Buzzer

Sounds when a failure is detected or when the emergency mode is activated.

* The buzzer sounds with the same tone in either case.

4. Buzzer Volume Control [SP]

Adjusts the volume of the buzzer (3).

5. Microphone Volume Control [MIC]

Adjusts the volume of the emergency microphone (20).

6. Microphone Holder

Holder for the emergency microphone (20).

7. CPU ON/OFF Switch [CPU]

Turns the CPU on and off. Normally set to the ON position. Turning this switch off allows all-zone calls by the CPU OFF function. To use the CPU OFF function, Switch 8 of the DIP switch (22) on the bottom surface must be set to ON. (Refer to ["CPU OFF Function" on page 47](#) for details.)

8. Indication Label Holder

Write the name, purpose, etc. of the indicator and key on a label and insert the label into the holder from the top. Labels can be printed using the setting software. (For more information, refer to "Printing Remote Microphone Labels" in the separate software manual.)

9. Communication Failure Indicator (yellow/green) Flashing Yellow

Indicates that a failure has been detected in communications with the VM-3240VA.

Lit Green

Indicates that the unit is in maintenance mode*. In this event, the unit does not work. To return to normal condition, set Switch 1 of the DIP switch (22) on the bottom surface to OFF.

* Unit is placed in this mode if Switch 1 of DIP switch (22) on the bottom surface is set to ON.

10. CPU OFF Indicator (red)

Lights when the unit is placed in CPU OFF mode using the CPU OFF switch.

11. RM Reset Key

Resets the unit.

12. Evacuation Announcement Indicator (red)

Lights when Evacuation announcements are made.

13. Evacuation Announcement Start Key

Plays the Evacuation announcement when in emergency mode. When the RM-320F Fireman's Microphone Extension is used, the announcement is broadcast over the zone(s) selected by the RM-320F. Pressing this key without first selecting the zones automatically makes an all-zone call. To stop the Evacuation announcement, hold down the key for 3 seconds.

14. Alert Announcement Indicator (red)

Lights when an Alert announcement is made.

15. Alert Announcement Start Key/Lamp Test Key

Plays the Alert announcement when in emergency mode. When the RM-320F Fireman's Microphone Extension Unit is used, the announcement is broadcast over the zone(s) selected by the RM-320F. Pressing this key without first selecting the zones automatically makes an all-zone call. To stop the Alert announcement, hold down this key for 3 seconds. Pressing this key during general broadcast mode allows a lamp test to be conducted.

16. Emergency Reset In-Progress Indicator (red)

Remains lit while the Emergency Reset key (17) is pressed.

17. Emergency Reset Key

Terminates emergency broadcasts to return to general broadcasts.

18. Emergency Microphone In-Use Indicator (green)

Lights when the Emergency Microphone (20) is used for broadcasts.

19. External Emergency Equipment In-Use Indicator (orange/green)

Flashes when external emergency equipment is used for broadcasts.

Orange: Indicates the mode that disables broadcasts from the unit.

Green: Indicates the mode that allows the unit to interrupt broadcasts from external equipment.

20. Emergency Microphone

After the emergency mode is activated, press the Talk key located on the side of the microphone to make an all-zone call or emergency broadcast over the selected zones (the RM-320F is required for zone selection).

21. RM-320F Connector

Connect the RM-320F Fireman's Microphone Extension Unit to this connector.

22. DIP Switch

Used to set the unit ID number and equipment functions. (Refer to ["DIP Switch Functions" on page 89.](#))

Switch 1 [MAINTENANCE]

Always set this switch to the OFF position.
Default setting: OFF
(Refer to ["Maintenance Mode" on page 91.](#))

Note

If this switch is set to ON, the unit is placed in the maintenance mode and the front panel-mounted Communication Failure indicator (9) lights green, causing the unit not to work.

Switches 2 – 4

Not used.

Default setting: OFF

Switch 5 [UNIT ID]

Sets the ID number of the Fireman's Microphone.

Default setting: ON

(Refer to ["Unit ID Number Settings" on page 90.](#))

Switch 6 [COMPRESSION]

Enables/disables compression.

Default setting: ON

(Refer to ["Compression Settings" on page 90.](#))

Switch 7 [TERMINATION]

Sets the RM-300MF Fireman's Microphone that functions as a terminating unit.

Default setting: OFF

(Refer to ["Setting the Terminating RM-300MF Unit" on page 91.](#))

Switch 8 [CPU OFF]

Enables/disables the CPU OFF function.

Default setting: ON

(Refer to ["CPU OFF Function Enable/Disable Settings" on page 91.](#))

23. Relay Connector

Connects to the relay connector (24) of the wall mount bracket unit (accessory).

24. Relay Connector

Connect the cable from the RM-300MF Fireman's Microphone to this connector.

25. Screw Terminal Block

RM Communication Line [DATA (+), DATA (-)]

A control/communication line between the RM-300MF Fireman's Microphone and the VM-3240VA .

Audio Output Line [AUDIO OUT H/C]

Audio output line from the RM-300MF Fireman's Microphone to the VM-3240VA.

DC Power Supply Input [DC IN 24V +/-]

Power supply line from the VM-3240VA to the RM-300MF Fireman's Microphone.

Shield [SHIELD]

Control line used by the VM-3240VA for confirmation of RM-300MF connections. Ensure that at least one shield is connected.

4.4. RM-320F Fireman's Microphone Extension

The RM-320F is an expansion unit for the RM-300MF Fireman's Microphone. Up to 3 Expansion Units can be added, expanding the available function keys to up to 20 per unit. Zone selection (1 – 20) and failure indication/acknowledgement functions can be assigned to each function key using the dedicated software.

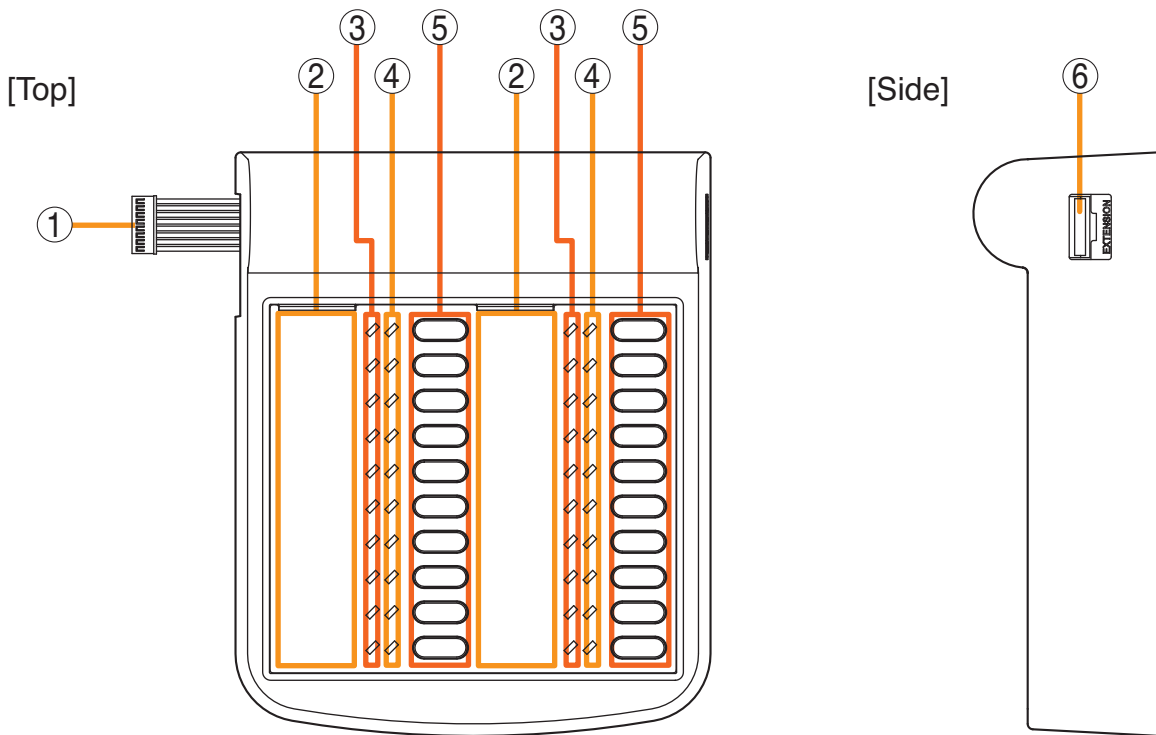

1. Connection Cable

Used for connection to the RM-300MF or RM-320F.

2. Indication Label Holder

Write the name, purpose, etc. of the indicator and key on a label and insert the label into the holder from the top. Labels can be printed using the setting software. (For more information, refer to "Printing Remote Microphone Labels" in the separate software manual.)

3. Emergency Broadcast Zone/Failure Indicators

Indicator function assigned to each indicator is determined by software settings.

Emergency Broadcast Zone Indicators (red)

Light to indicate emergency announcement broadcast zones.

Failure Indicators (yellow)

Flash yellow (before failure acknowledgment) or light yellow (after failure acknowledgment) when a failure is detected.

Failure Reset Indicators (yellow)

Remain lit while the Failure Reset key is pressed.

4. Broadcast Zone Indicators (green)

Light to indicate the corresponding selected zone.

5. Broadcast Zone Selector / Failure Acknowledgment Keys / Failure Reset Key

Key function assigned to each key is determined by software settings.

Broadcast Zone Selector Keys

Select broadcast zones when in Emergency mode.

Failure Acknowledgment Keys

Keys can be set to acknowledge failures. When an assigned failure occurs, pressing the corresponding key acknowledges the failure.

Failure Reset key

Key can be set to reset functions. When a failure occurs, remove the cause of the failure, then press the corresponding key, reverting the unit back to normal mode.

6. Expansion Connector

Connect the RM-320F Fireman's Microphone Extension to this connector.

4.5. RM-200M Remote Microphone

The RM-200M Remote Microphone connects to the VM-3240VA for the purpose of making general broadcast announcements. It communicates with the VM-3240VA through its RS-485 interface. Zone selection or automatic announcement start can be assigned to the function key using the dedicated software. No emergency broadcasts can be made with this microphone.

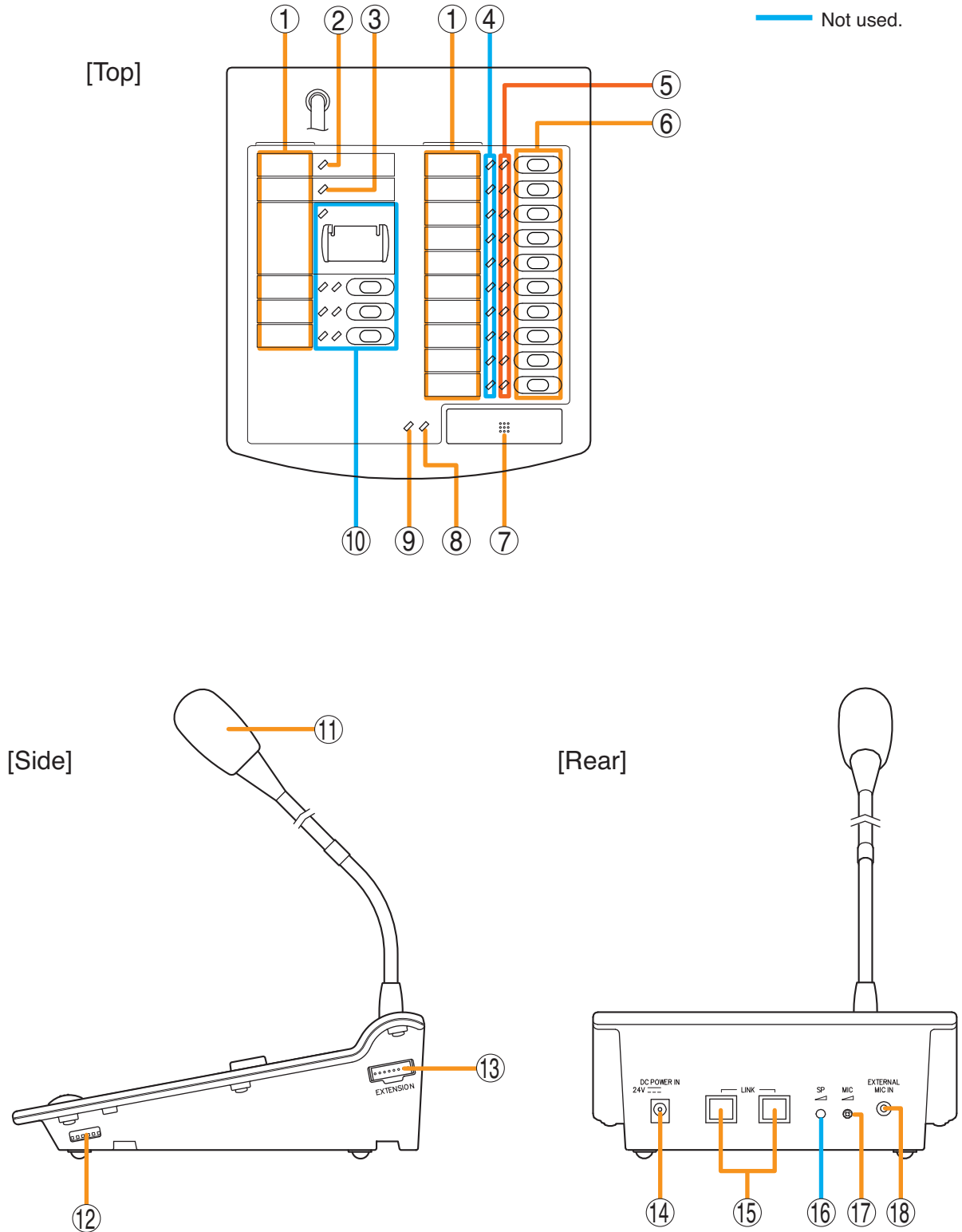

1. Indication Label Holder

Write the name, purpose, etc. of the indicator and key on a label and insert the label into the holder from the top. Labels can be printed using the setting software. (For more information, refer to "Printing Remote Microphone Labels" in the separate software manual.)

2. Power Indicator (green)

Lights when power is supplied to the unit.

3. Communication Failure Indicator (yellow)

Flashes when a failure is detected in communications with the VM-3240VA.

4. Not used.

Lights when the system is in emergency status.

5. Broadcast Zone / Automatic general broadcast Announcement Start Indicators (green)

Indicator's function assigned to each indicator is determined by software settings.

Broadcast Zone Indicators

Light when their corresponding zones are selected.

Automatic general broadcast Announcement Start Indicators

Light when an automatic announcement is started.

6. Broadcast Zone Selector / Automatic general broadcast Announcement Start Keys

Key function assigned to each key is determined by software settings.

Broadcast Zone Selector Keys

Select broadcast zones. Pressing the Talk key (7) after zone selection allows microphone announcements to be broadcast over the selected zone(s).

Automatic general broadcast Announcement Start Key

Automatic general broadcast announcements are broadcast over the selected zone(s).

7. Talk Key

This key is used for general broadcast microphone announcements. Pressing the Talk key after zone selection allows microphone announcements to be broadcast over the selected zone(s).

8. Talk Indicator (green)

Lights when the Talk key (7) is pressed.

9. External Microphone In-Use Indicator (orange / green)

Flashes when a paging call is made from the external remote microphone.

Orange: Indicates the mode that disables broadcasts from the unit.

Green: Indicates the mode that allows the unit to interrupt broadcasts from external equipment.

10. Not used.

11. Microphone

Used for making announcements.

12. DIP Switch

Used to set the unit ID number and equipment functions. (Refer to "[DIP Switch Functions](#)" on [page 89](#).)

Switches 1 and 2

Set the ID number of the Remote Microphone.

Default setting: ON

(Refer to "[Unit ID Number Settings](#)" on [page 90](#).)

Switch 3

Not used.

Default setting: ON

Switch 4

Sets the Talk key's operating system.

Default setting: ON

(Refer to "[Talk Key Settings](#)" on [page 91](#).)

Switch 5

Not used.

Default setting: ON

Switch 6 [COMPRESSION]

Enables/disables compression.

Default setting: ON

(Refer to "[Compression Settings](#)" on [page 90](#).)

13. RM-210 Connector [Extension]

Connect the added RM-210 Remote Microphone Extension to this connector.

14. Power Supply Input Connector

The VM-3240VA can only supply power to one RM-200M Remote Microphone. Connect the power supply to this connector when using multiple Remote Microphones or Fireman's Microphone Extensions.

15. Link Connector (RJ45 Connector)

Connects to the VM-3240VA's, RM-300MF's or other RM-200M's LINK connector.

16. Not used.

17. Microphone Volume Control

Adjusts the volume of the unit's microphone (11).

Rotate clockwise to increase the microphone volume.

Rotate counterclockwise to decrease the microphone volume.

18. External Microphone Input Jack (3.5 mm mini jack)

An electret condenser microphone can be connected to this terminal. Connecting a microphone to this jack disables the unit's microphone (11).

4.6. RM-210 Remote Microphone Extension

The RM-210 is an expansion unit for the RM-200M Remote Microphone. Up to 4 Expansion Units can be added, expanding the available function keys to up to 10 per unit. Zone selection or automatic announcement start functions can be assigned to each function key using the dedicated software. Only the right-side indicators are used.

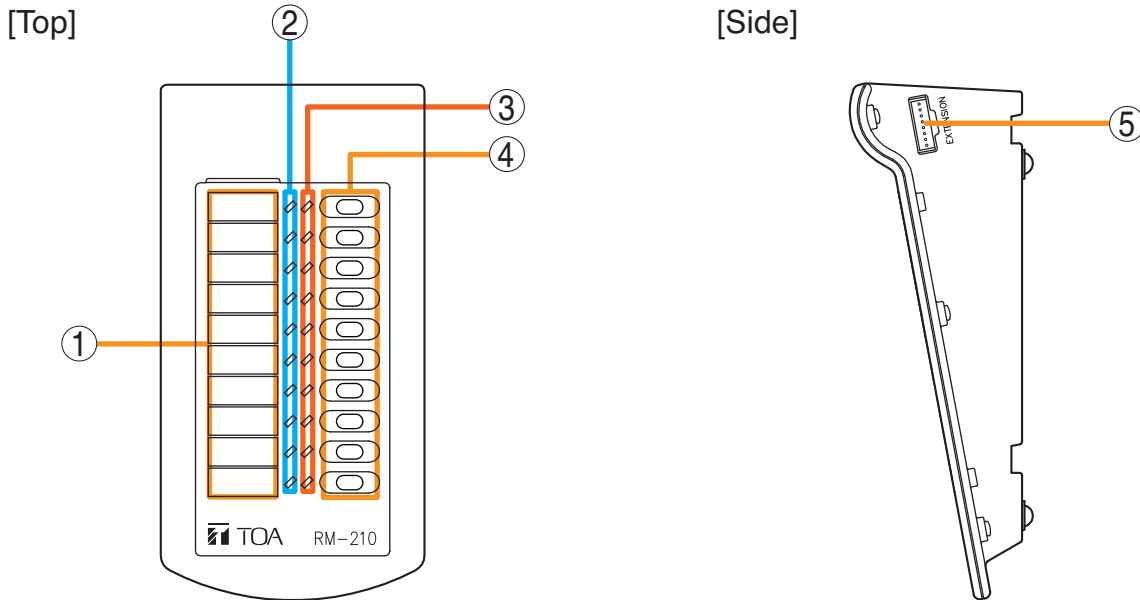

1. Indication Label Holder

Write the name, purpose, etc. of the indicator and key on a label and insert the label into the holder from the top. Labels can be printed using the setting software. (For more information, refer to "Printing Remote Microphone Labels" in the separate software manual.)

2. Not used.

3. Broadcast Zone / Automatic Announcement Start Indicators (green)

Indicator's function assigned to each indicator is determined by software settings.

Broadcast Zone Indicators

Light when their corresponding zones are selected.

Automatic general broadcast Announcement Start Indicators

Light when an automatic announcement is started.

4. Broadcast Zone Selector Keys/ Automatic Announcement Start Keys

Key function assigned to each key is determined by software settings.

Broadcast Zone Selector Keys

Select broadcast zones. Pressing the RM-200M Remote Microphone's Talk key (7) after zone selection allows microphone announcements to be broadcast over the selected zone(s).

Automatic general broadcast Announcement Start Key

Automatic general broadcast announcements are broadcast over the selected zone(s).

5. Connector [Extension]

Connect the RM-200M Remote Microphone or additional RM-210 Remote Microphone Extension to this connector.

The same terminal is provided on the other side as well.

4.7. VP-2241 Power Amplifier

The VP-2241, featuring 240 W x 1 channel, is designed for use in the VM-3000 system. Mount a VP-200VX Power Amplifier Input module to the module slot on the rear.

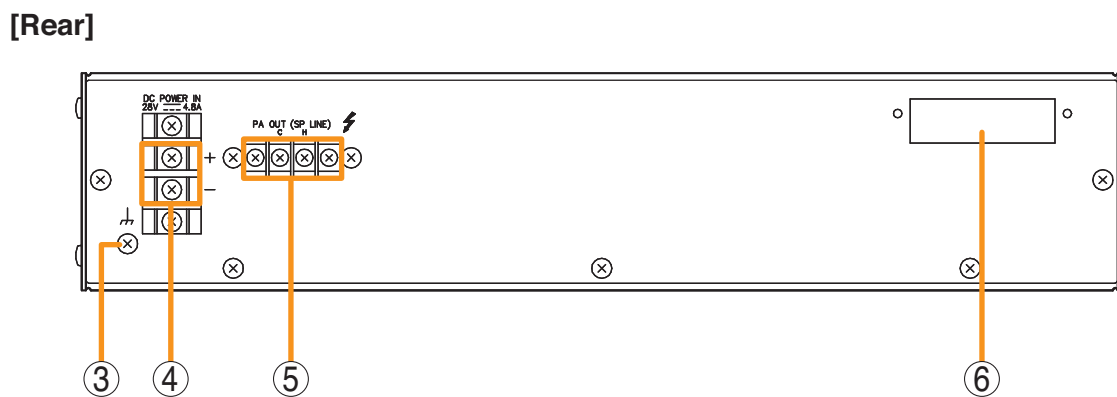
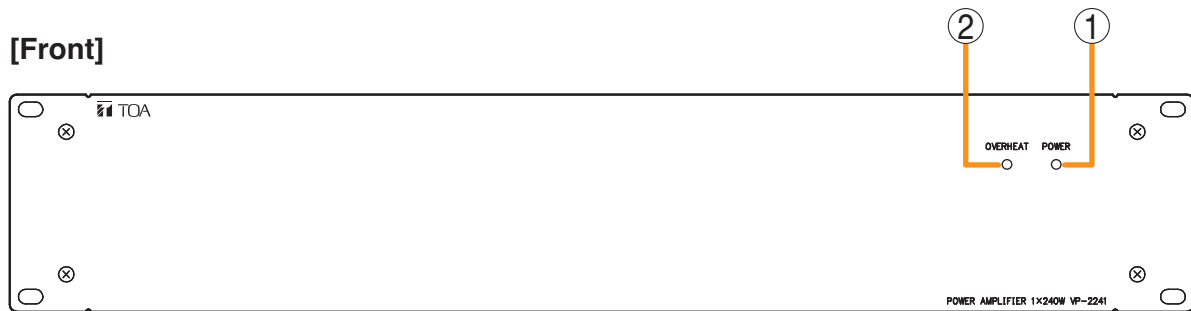

1. Channel power indicator [POWER]

Lights green when the power is supplied with the input module mounted.

- Off: VP-200VX not installed
- Lights green: In-use status
- Lights red: Standby status or DC fuse blowout

2. Overheat indicator [OVERHEAT]

If the internals of the power amplifier overheat, this indicator lights yellow and the power amplifier's operation is stopped.

3. Ground terminal

4. DC power inputs [DC POWER IN]

Connect to the VX-2000DS Emergency Power Supply's DC POWER OUT terminal.

5. Output terminals [PA OUT (SP LINE)]

Connect to the power amplifier input terminal of the VM-3240VA or VM-3240E.

The speaker line output voltage can be changed with an internal modification.

6. Module slot

Insert the VP-200VX Power Amplifier Input module into this slot.

4.8. VP-200VX Power Amplifier Input Module

Insert this module into the Power Amplifier's Input module slot when in use.

[Front]

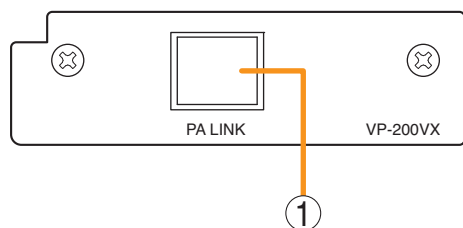

1. Input connector [PA LINK]

This RJ45 connector connects to the VM-3240VA's EXT. PA LINK connector.

Output audio signals are transmitted to the power amplifier, and the power amplifier's audio monitor signals are returned to the module.

It is also possible to retrieve data regarding power amplifier overheating status and blown DC fuses.

5. MAKING GENERAL BROADCASTS

5.1. Making Broadcasts from the VM-3240VA

5.1.1. BGM broadcasts

Broadcast musical programs from the BGM sound source connected to BGM input terminals 1 or 2 located on the rear panel of the VM-3240VA. Adjust the BGM volume control and the volume control of the designated speakers to an appropriate sound level in advance.

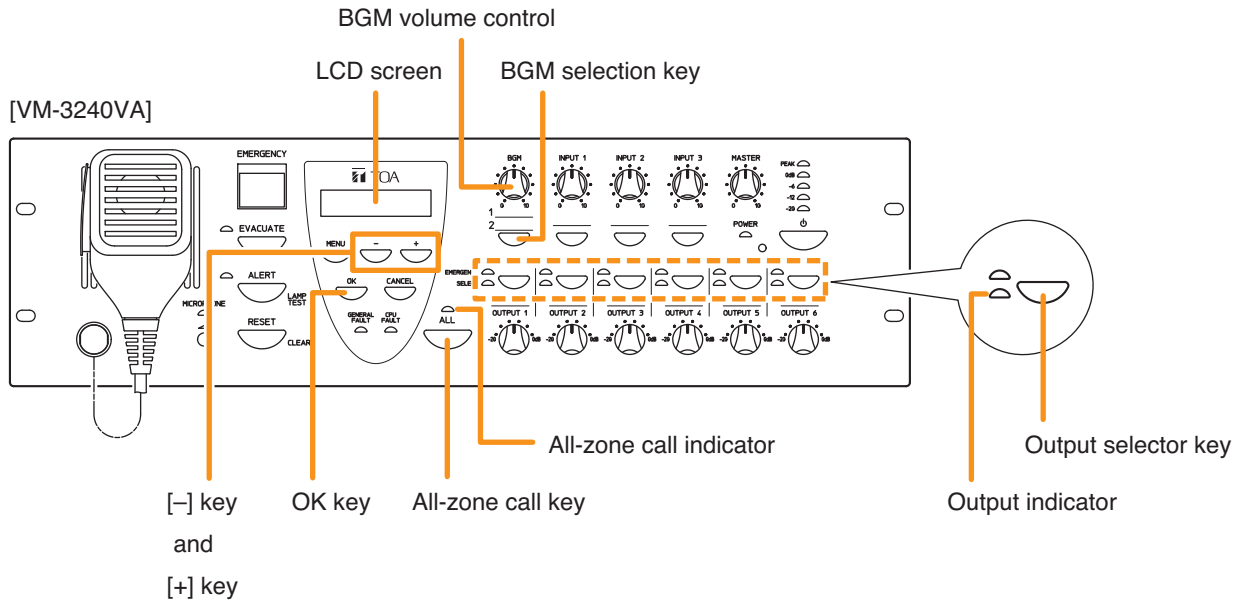

Step 1. Press the BGM selection key. The "Select BGM" screen will be displayed on the LCD.

Step 2. Select either BGM 1 or BGM 2 with the [+] or [-] key.

Step 3. Press the [OK] key to confirm the selected BGM program.

Step 4. Press the all-zone call key or output selector key to select the broadcast zone, then begin the BGM broadcast.

- Pressing the all-zone call key causes the all-zone call indicator to light green, enabling BGM broadcasts over an entire area.
- Pressing an output selector key causes the selected output's indicator to light green, allowing the BGM program to be broadcast over the corresponding zone.

Step 5. To terminate the BGM broadcast, press either the all-zone call key or output selector key again. The indicator goes out and the BGM broadcast is terminated.

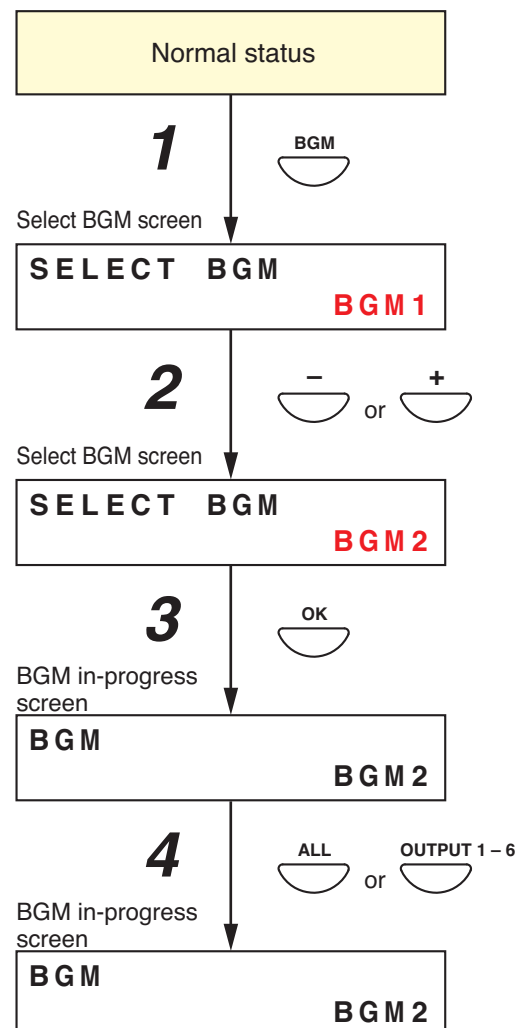

5.1.2. Microphone announcements

Make voice broadcasts using the microphone connected to any of audio input terminals 1 – 4 located on the rear panel of the VM-3240VA. Perform input sensitivity settings (Line/Mic selection) while viewing the LCD. (Refer to "Input 1 – 3 Settings" on page 85.) Also, adjust the volume control for the input the microphone is connected to (Inputs 1 – 4) and the speaker output volume control for the broadcast zone to an appropriate volume in advance.

Note

The microphone on the front panel is intended for emergency broadcasts only. It cannot be used for general broadcasts.

[Front panel-mounted key operation for microphone announcements]

Perform the following setting in advance using the setting software:

Set the priority level of the audio input terminal to which the microphone is connected to "7" (MIX). (Refer to "General Broadcast Priorities" on page 45 for priority levels, and to "Priority Settings" in the separate software manual for how to set priorities.)

Step 1. Press either the all-zone call key or output selector key to select the broadcast zone.

- Pressing the all-zone call key causes the all-zone call indicator to light green, enabling microphone announcement broadcast over an entire area.
- Pressing an output selector key causes the selected output's indicator to light green, allowing the microphone announcement to be broadcast over the corresponding zone.

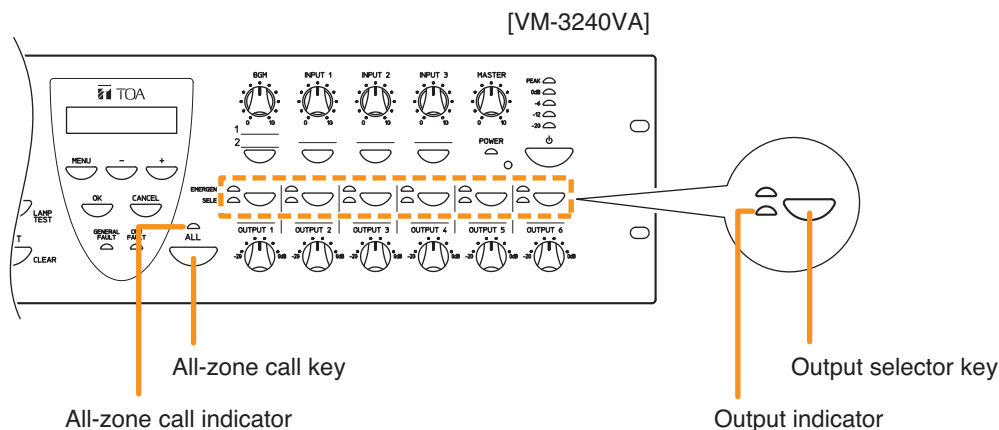

Step 2. Make a microphone announcement using the microphone connected to the audio input terminal on the rear panel.

Step 3. To terminate the microphone announcement, press the all-zone call key or the same output selector key again.

The corresponding indicator goes out, terminating the microphone announcement.

[Making microphone announcements by activating control inputs]

Perform the following settings in advance using the setting software:

- Set the priority level of the audio input terminal to which the microphone is connected to any of "1" – "6". (Refer to "General Broadcast Priorities" on page 45 for priority levels, and to "Priority Settings" in the separate software manual for how to set priorities.)
- Perform settings so that a microphone announcement is broadcast over designated broadcast zones when the control input terminal is activated. (For more information, refer to "General Control Input Settings" in "Event Settings" in the separate software instruction manual.)

Step 1. Close ("Make") the Control Input terminals on the rear panel of the VM-3240VA.

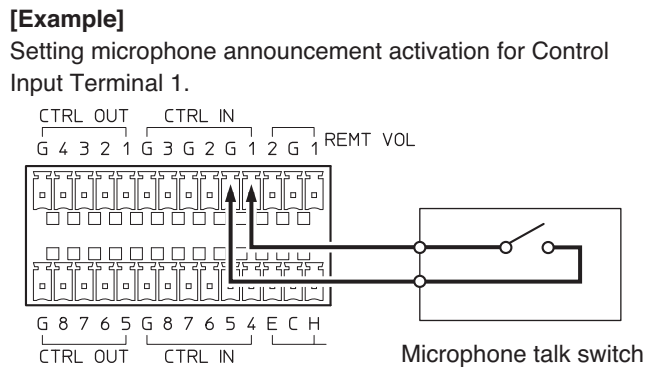
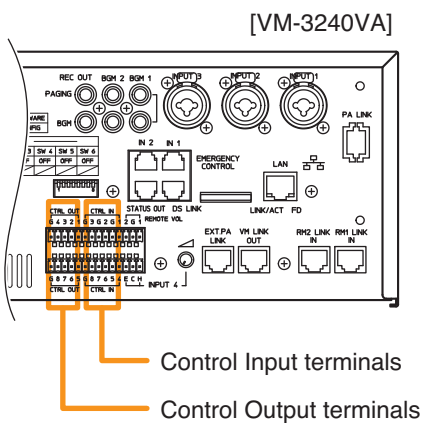

The corresponding all-zone call or output indicator lights green, allowing microphone announcements to be broadcast from the corresponding speaker line.

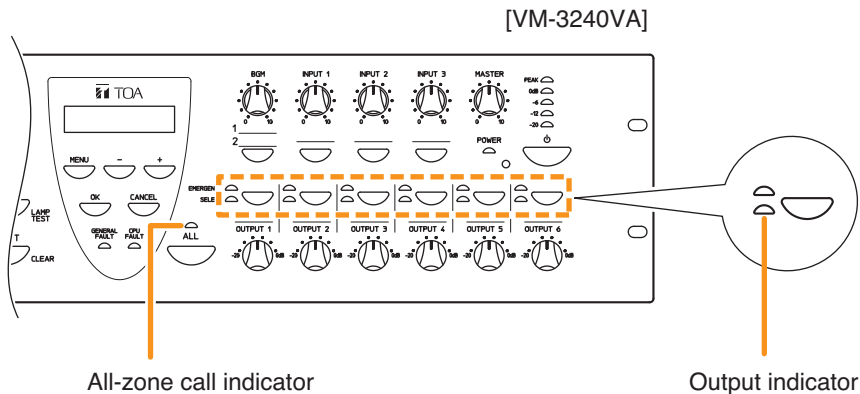

In this event, if interlock outputs have been set, a set contact is provided from the Control Output terminal. (For interlock output settings, refer to "General Control Input Settings" in "Event Settings" in the separate software instruction manual.)

Step 2. Make a microphone announcement using the microphone connected to the audio input terminal on the rear panel.

Step 3. To terminate the microphone announcement, open ("break") the Control Input terminals. The corresponding indicator goes out, terminating the microphone announcement.

5.2. Broadcasting from the RM-200M

5.2.1. Microphone announcements

Use the RM-200M's microphone to make announcements.

Perform the following settings in advance using the setting software:

Assign a broadcast zone selection function to the key.
(Refer to "RM Function Key Settings" in "Event Settings" in the separate software instruction manual.)

Step 1. Press the broadcast zone selector key to select the broadcast zone.

The selected zone's indicator lights green, allowing microphone announcements to be broadcast over the zone assigned to the key.

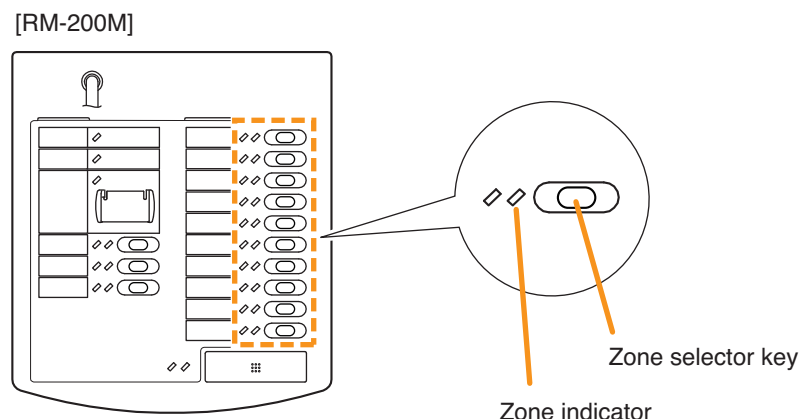

Step 2. Press the Talk key to make an announcement.

The talk indicator lights green while the Talk key is pressed.

Notes

Two modes are available for Talk key operation: "PTT" and "Lock" modes.

- When the talk key is set to PTT mode, announcements can only be broadcast while the Talk key is held down. Releasing the Talk key terminates the broadcast and extinguishes the indicator.
- When set to Lock mode, pressing the Talk key initiates a broadcast and pressing the key again terminates the broadcast and extinguishes the indicator.

To set the Talk key mode, use the DIP switch located on the side of the RM-200M.

(Refer to "Talk Key Settings" on page 91 for DIP switch settings.)

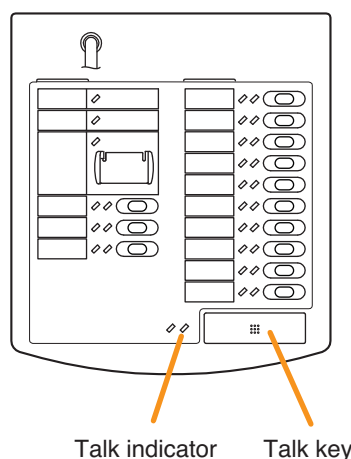

5.2.2. Automatic announcement broadcasts

This function makes general broadcasts by activating and playing back automatic announcements recorded and stored in the VM-3240VA.

Perform the following settings in advance using the setting software:

- Assign a broadcast zone selection to the key.
(Refer to "RM Function Key Settings" in "Event Settings" in the separate software instruction manual.)
- Assign an automatic announcement function to the key.
(Refer to "RM Function Key Settings" in "Event Settings" in the separate software instruction manual.)

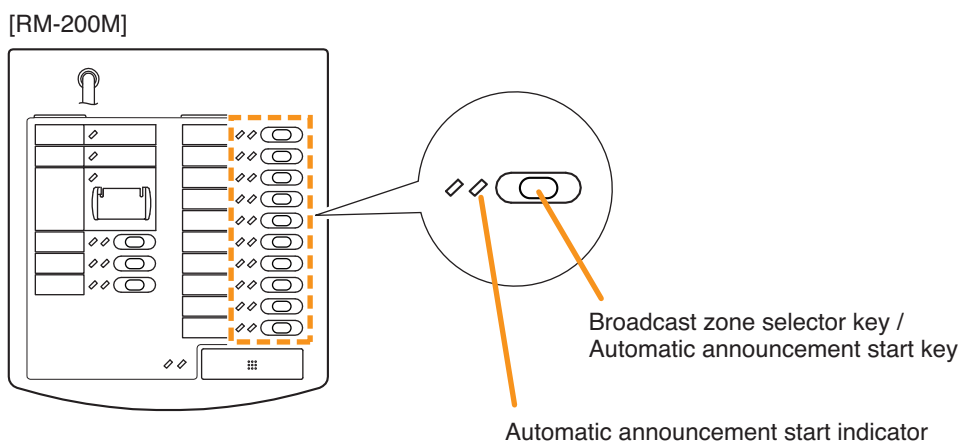

Step 1. Press the broadcast zone selector key to select the broadcast zone.

The selected zone's indicator lights green, allowing the automatic announcement assigned to that key to be broadcast.

Step 2. Press the automatic announcement start key to start the broadcast. The automatic announcement indicator lights green and the automatic announcement is broadcast over the selected zone.

Step 3. When the automatic announcement playback is complete, the indicator goes out and the broadcast is terminated.

Note

Pressing the automatic announcement start key partway through playback causes the broadcast to be terminated and the indicator to go out.

5.3. Making Automatic Announcements Using Control Signal Inputs

This function makes general broadcasts by playing back internal automatic announcements activated when the control input terminals located on the rear panel of the VM-3240VA or VM-3240E receive a broadcast control signal.

Perform the following settings in advance using the setting software:

Make settings so that the automatic general announcement is broadcast over the designated zone(s) when the control input terminals of the VM-3240VA or VM-3240E are activated.
 (For more information, refer to "VM-3000VA Settings" or "VM-3000E Settings" in "System Settings" in the separate software instruction manual.)

Step 1. Connect a timer or other external control device to the control input terminals located on the rear panel of the VM-3240VA or VM-3240E.

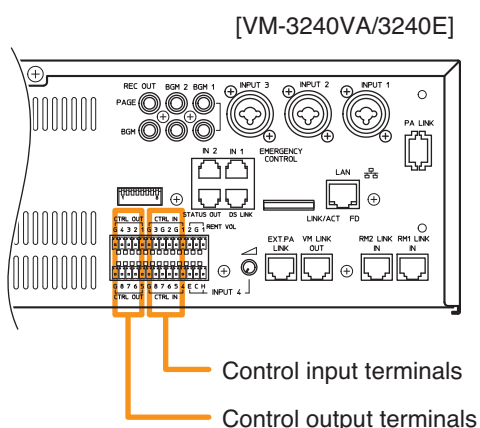

[Example] Connecting a timer to Control Input Terminal 1

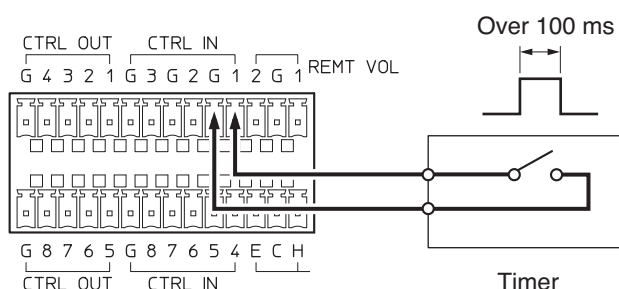

Note: This figure represents the VM-3240VA.

Step 2. When the timer's preset time is reached, the Contact Input receives a contact output signal (make contact) from the timer. The all-zone call indicator or output indicator corresponding to the set zone lights green and the automatic general announcement is broadcast over that zone.

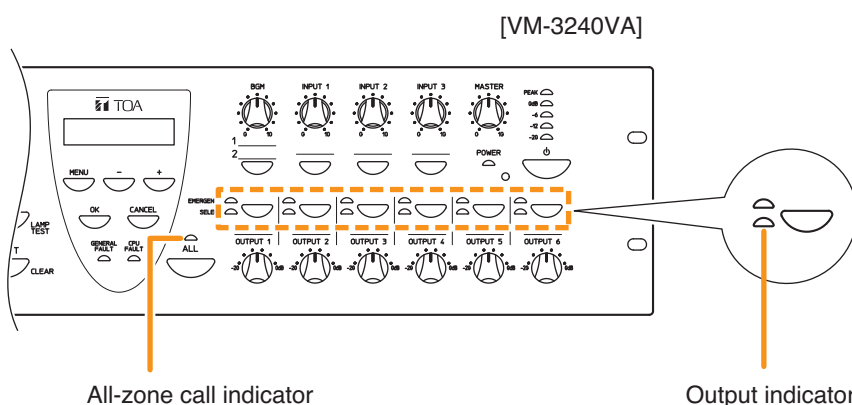

At the same time, a set contact is output from the control output terminal if interlock outputs have also been set. (For interlock output settings, refer to "General Control Input Settings" in "Event Settings" in the separate software instruction manual.)

Step 3. After the automatic general announcement playback is complete, the broadcast is terminated and the indicator goes out.

5.4. Summary of General Broadcast Procedures

5.4.1. Making general broadcasts from the VM-3240VA

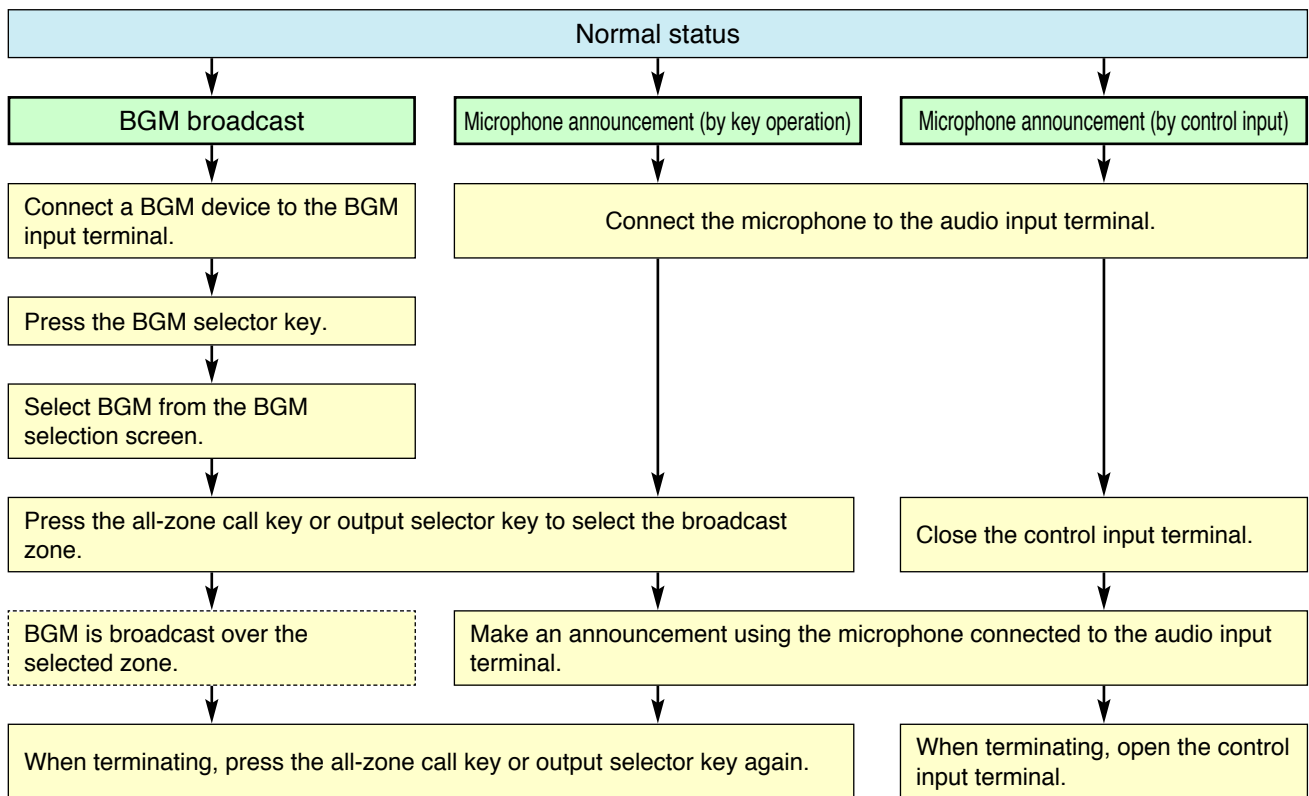

5.4.2. Making general broadcasts from the RM-200M Remote Microphone

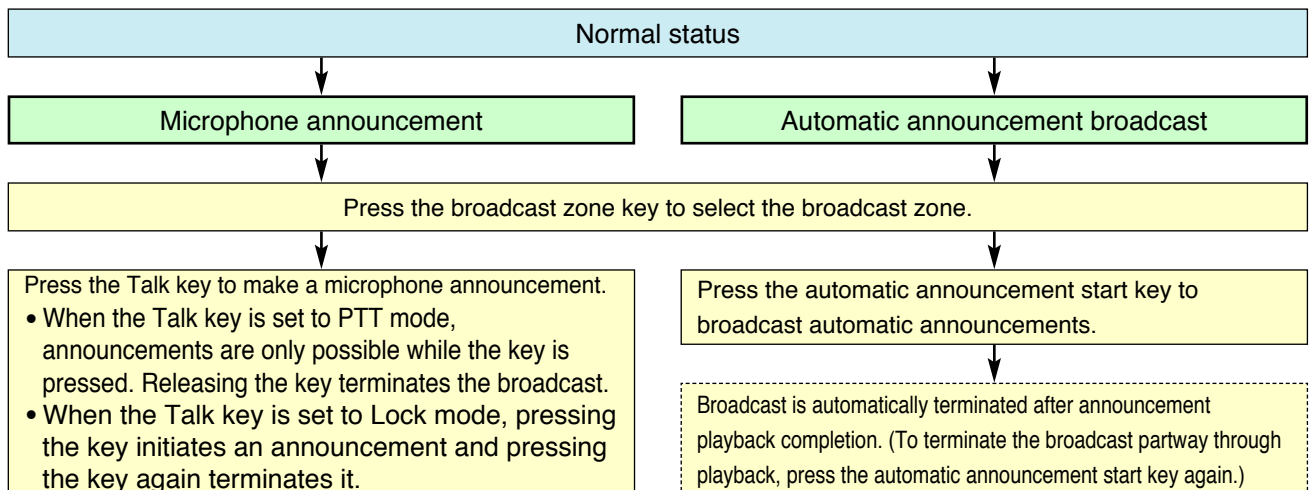

5.4.3. Broadcasting automatic general announcements using the control signal input

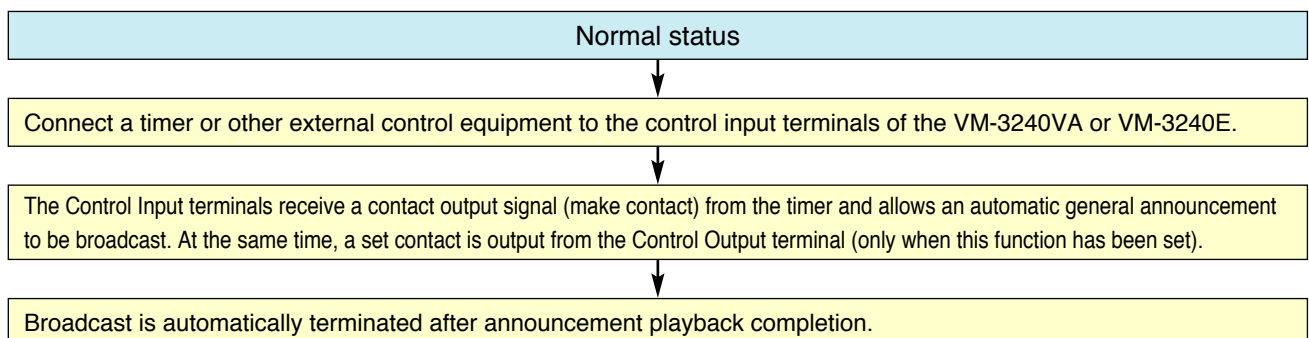

6. MAKING EMERGENCY BROADCASTS

The following 3 methods are mainly used for making emergency broadcasts:

- Press the Emergency Activation switch on the front panel of the VM-3240VA to initiate emergency broadcasts.
- Press the RM-300MF Fireman's Microphone's front panel-mounted Emergency Activation switch to initiate emergency broadcasts.
- Activate and broadcast automatic emergency announcements using the control signal input transmitted from an automatic fire alarm system or connected external equipment.

Note

To use the keys shown below, enable their functions on the setting software. (For details, refer to "Emergency Control Input Settings" in "Event Settings" in the separate software instruction manual.)

[VM-3240VA]

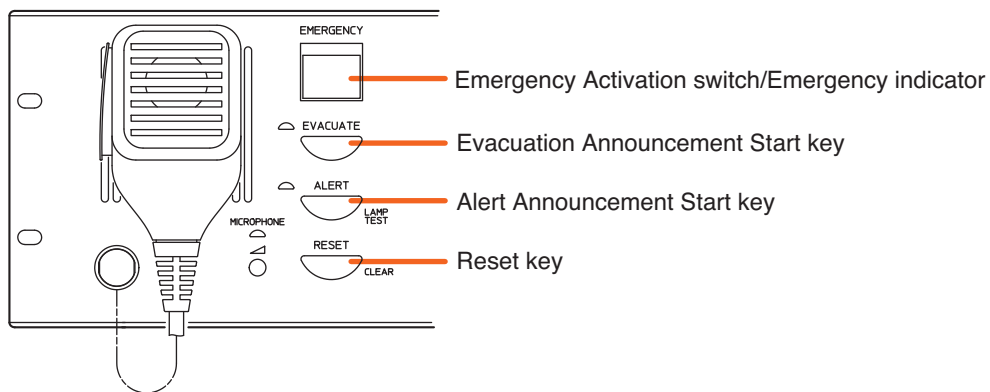

[RM-300MF]

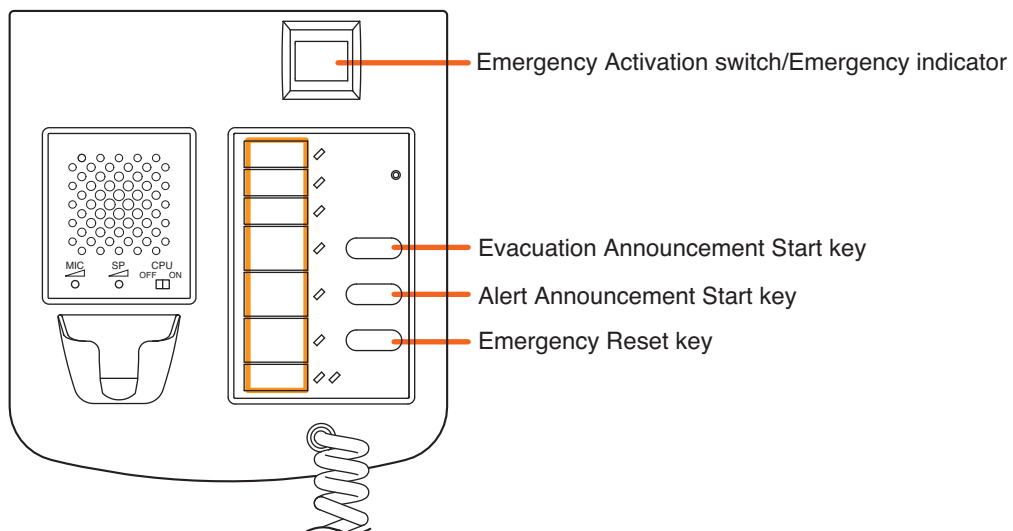

6.1. Making Emergency Broadcasts from the VM-3240VA

6.1.1. Microphone announcements

Use the emergency microphone located on the front panel of the VM-3240VA.

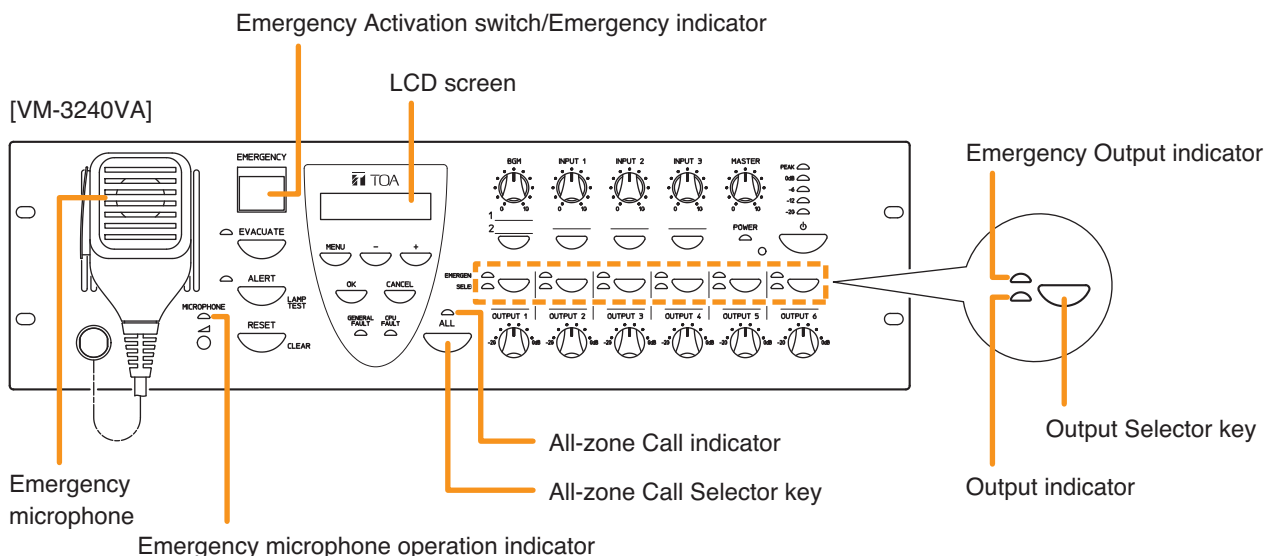

Step 1. Press the Emergency Activation switch.

The Emergency indicator (Emergency Activation switch) lights red and the VM-3240VA is placed in emergency broadcast mode. The indication requesting broadcast output selection is displayed on the LCD.

Step 2. Press the All-Zone Selector key or Output Selector key to select the broadcast zones.

- Pressing the All-Zone Call Selector key causes the All-Zone Call indicator to light green, allowing emergency broadcasts to be made over all broadcast zones.
- Pressing the Output Selector key causes the selected Output indicators to light green, allowing emergency broadcasts to be made over the corresponding broadcast zone(s).

Note

Skipping Step 2 allows emergency broadcasts to be made over all zones, as if the All-Zone Call Selector key was pressed.

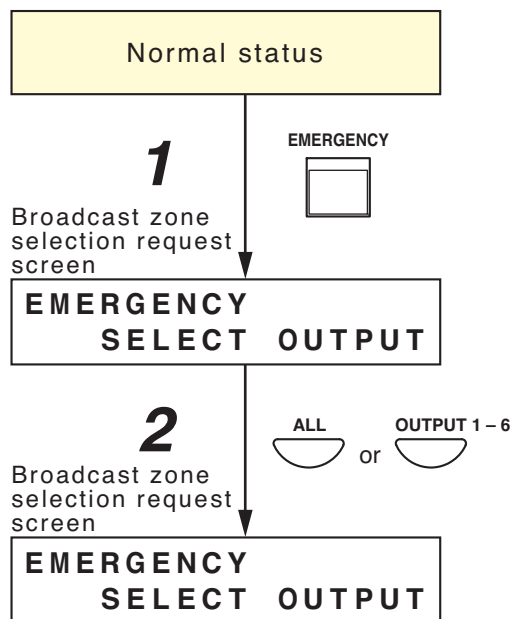

Step 3. Make announcement while pressing the emergency microphone's Talk key. During emergency microphone announcements, the Emergency Microphone Operation indicator and Output indicator both light red. At the same time, the "EMERGENCY VA MICROPHONE" indication is displayed on the LCD.

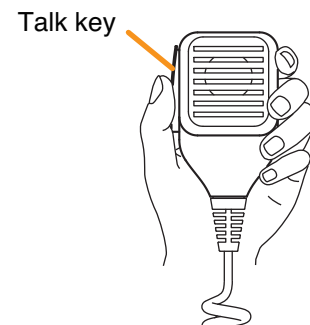

Step 4. To terminate the emergency broadcast, reset the emergency mode using one of the following methods:

- Press the Reset key on the front panel of the VM-3240VA.

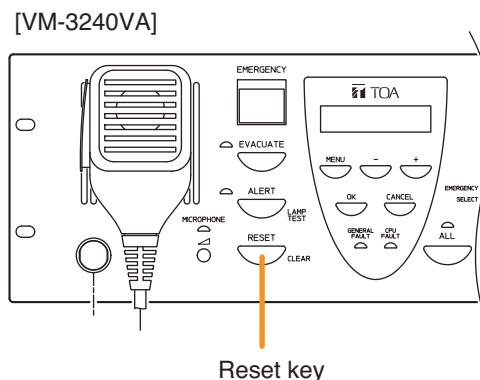

- Press the RM-300MF Fireman's Microphone Emergency Reset key.

Note

The Emergency Reset indicator (red) remains lit while the Emergency Reset key is pressed.

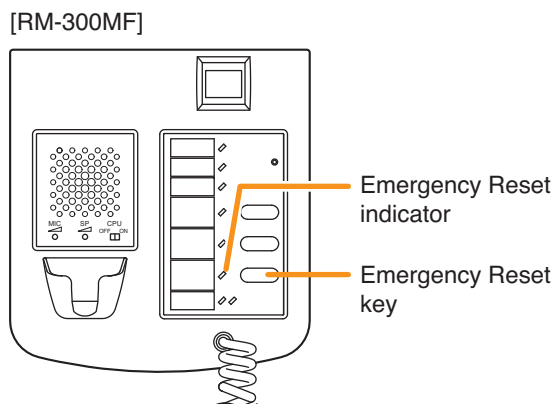

- Input a reset signal to the Emergency Control Input terminals of the VM-3240VA or VM-3240E which has been assigned a reset function.

Note

Use the setting software to assign the reset function to the Emergency Control Input terminal. (Refer to "Emergency Control Input Settings" in "Event Settings" in the separate software instruction manual.)

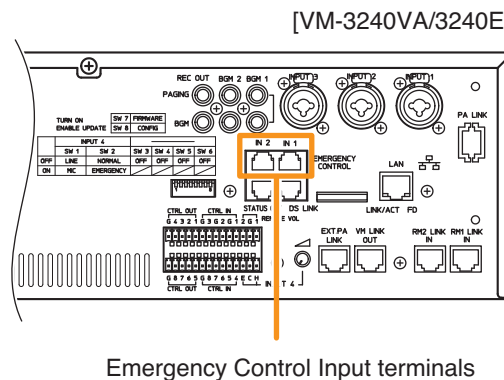

Note: This figure represents the VM-3240VA.

6.1.2. Automatic emergency announcement broadcasts

This function makes emergency broadcasts with the key on the VM-3240VA's front panel by playing back the Alert or Evacuation announcements recorded and stored in the VM-3240VA.

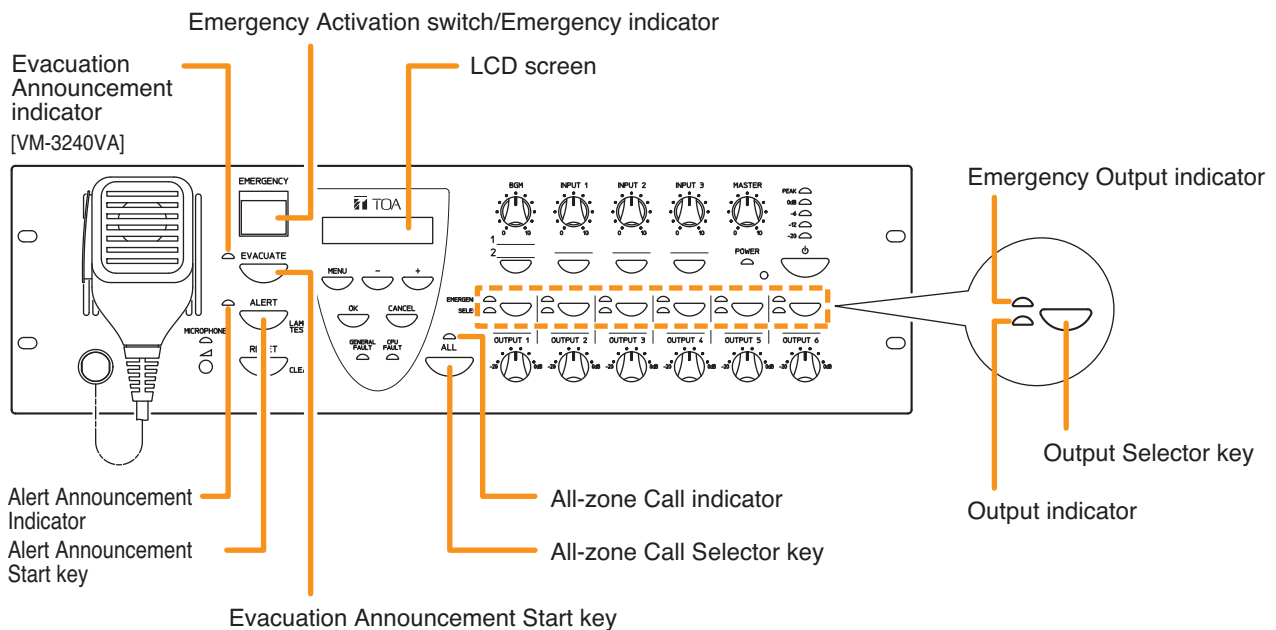

Step 1. Press the Emergency Activation switch.

The Emergency indicator (Emergency Activation switch) lights red and VM-3240VA is placed in emergency broadcast mode. The indication requesting broadcast output selection is displayed on the LCD.

Step 2. Press the All-Zone Call Selector key or Output Selector key to select the broadcast zones.

- Pressing the All-Zone Call Selector key causes the All-Zone Call indicator to light green, allowing emergency broadcasts to be made over all broadcast zones.
- Pressing the Output Selector key causes the selected Output indicators to light green, allowing emergency broadcasts to be made over the corresponding broadcast zone(s).

Note

Skipping Step 2 allows emergency broadcasts to be made over all zones, as if the All-Zone Call Selector key was pressed.

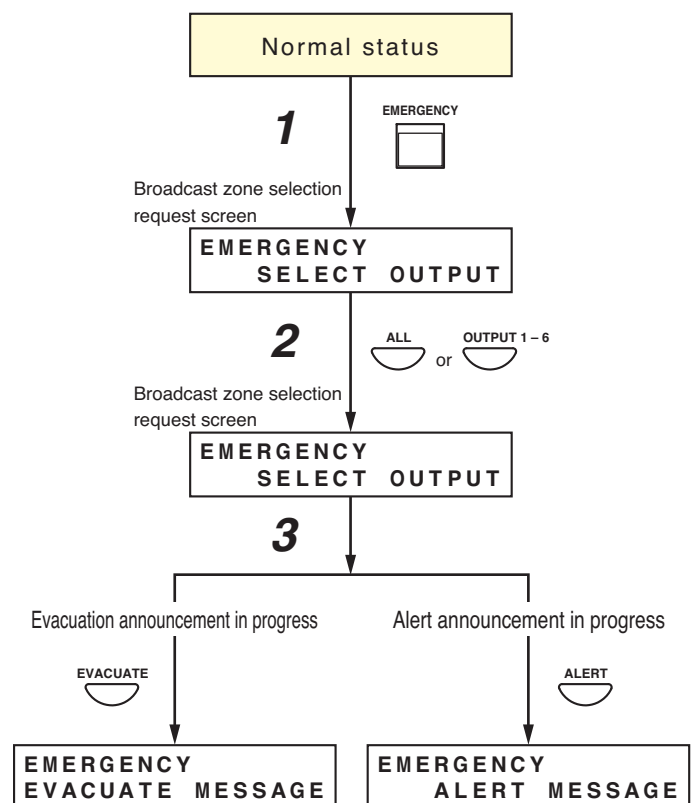

Step 3. Press either the Alert or Evacuation Announcement Start key.

The Alert Announcement indicator or Evacuation Announcement indicator and the Emergency Output indicator both light red, broadcasting the Alert or Evacuation announcement over the selected broadcast zone(s).

Note

Holding down the Alert Announcement Start key during Alert announcements or the Evacuation Start key during Evacuation announcements for 3 seconds or more causes the announcement to be terminated and the indicator to go out.

Step 4. To terminate the emergency broadcast, reset the emergency mode using one of the following methods:

- Press the Reset key on the front panel of the VM-3240VA.

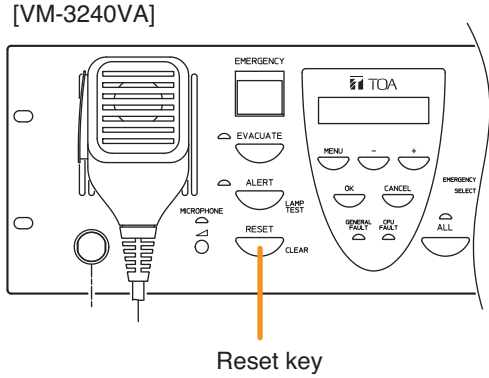

- Press the RM-300MF Fireman's Microphone Emergency Reset key.

Note

The Emergency Reset indicator (red) remains lit while the Emergency Reset key is pressed.

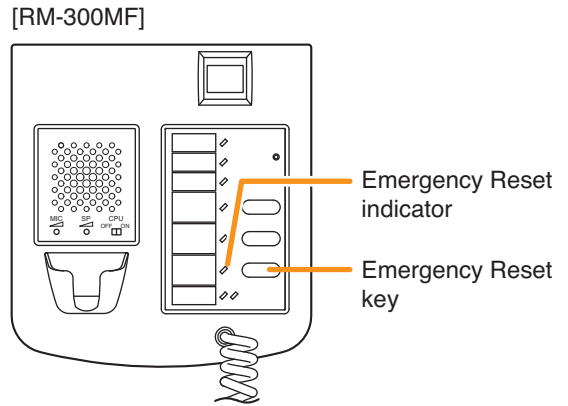

- Input a reset signal to the Emergency Control Input terminal of the VM-3240VA or VM-3240E which has been assigned a reset function.

Note

Use the setting software to assign the reset function to the Emergency Control Input terminal. (Refer to "Emergency Control Input Settings" in "Event Settings" in the separate software instruction manual.)

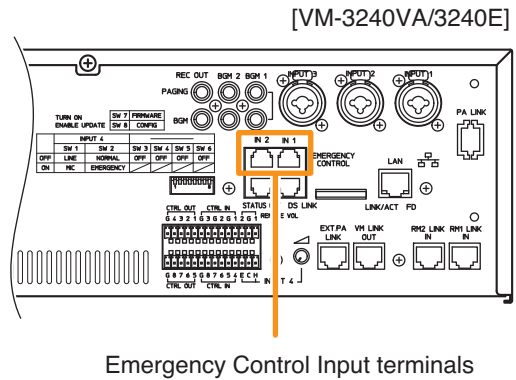

Note: This figure represents the VM-3240VA.

6.2. Making RM-300MF Emergency Broadcasts

6.2.1. Microphone announcements

Make emergency broadcasts through the emergency microphone of the RM-300MF Fireman's Microphone.

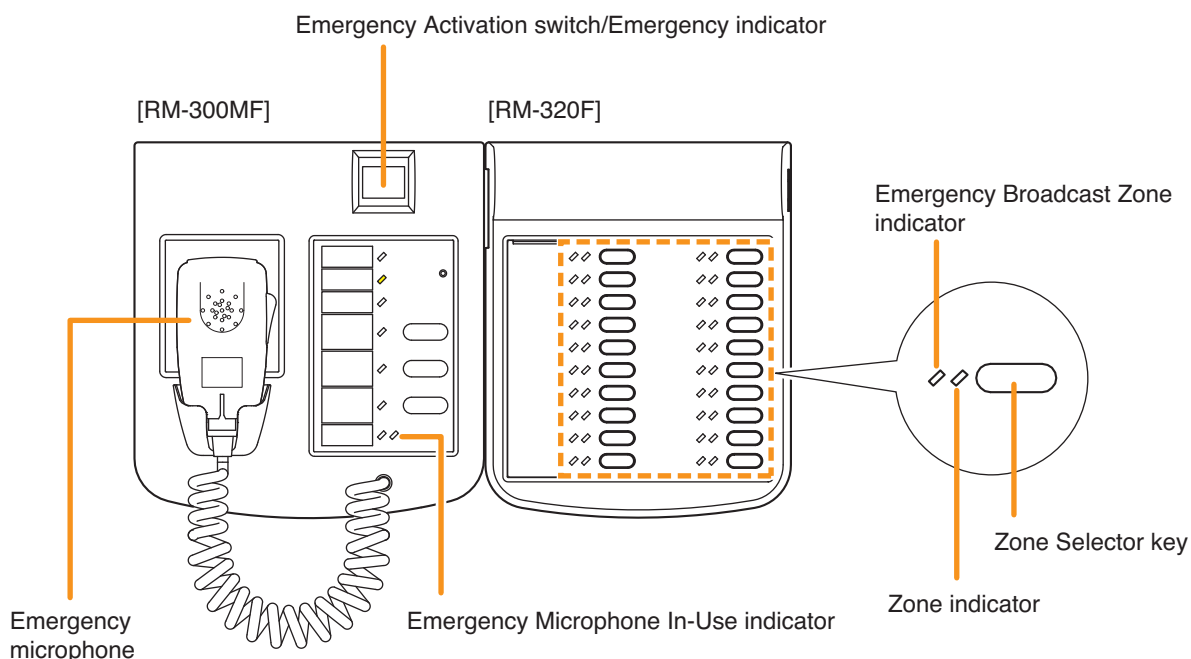

Step 1. Press the RM-300MF's Emergency Activation switch.

The Emergency indicator (Emergency Activation switch) lights red, placing the unit in emergency broadcast mode.

Step 2. Press the RM-320F Fireman's Microphone Extension's Zone Selector key(s) to select broadcast zone(s).

The selected zone's indicator lights green, indicating that emergency microphone announcements can be broadcast over the selected zone.

Notes

- The RM-320F Fireman's Microphone Extension is an optional device. If the Fireman's Microphone Extension is not connected, emergency announcements are broadcast over all broadcast zones.
- Use the setting software to set the Zone Selector key. (Refer to "Event Settings" → "RM Function Settings" → "RM-320F Settings" in the separate software instruction manual.)
- If Step 2 is skipped and the broadcast zone is not selected, emergency announcements are broadcast over all broadcast zones.

Step 3. Make emergency broadcasts by pressing the Talk key of the RM-300MF's emergency microphone.

During the emergency microphone announcement, the RM-300MF's Emergency Microphone In-Use indicator lights green and the RM-320F Fireman's Microphone Extension's Emergency Broadcast Zone indicator lights red.

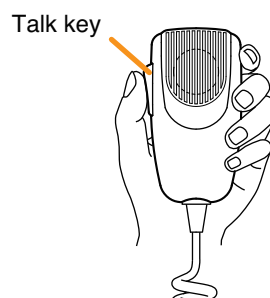

Step 1. To terminate the emergency broadcast, reset the emergency mode using one of the following methods:

- Press the Reset key on the front panel of the VM-3240VA.

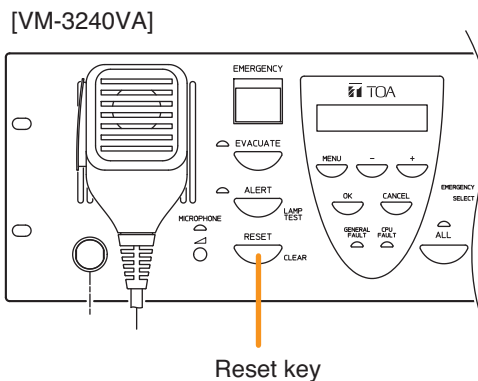

- Press the RM-300MF Fireman's Microphone Emergency Reset key.

Note

The Emergency Reset indicator (red) remains lit while the Emergency Reset key is pressed.

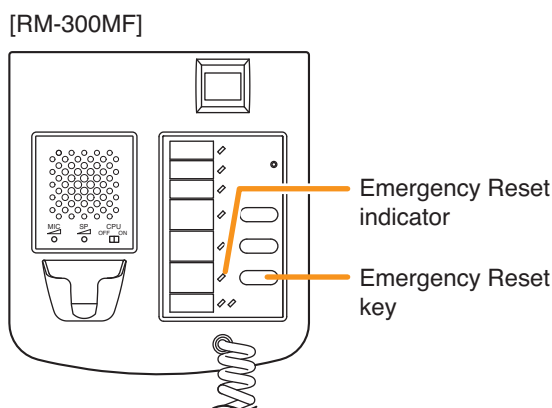

- Input a reset signal to the Emergency Control Input terminal of the VM-3240VA or VM-3240E which has been assigned a reset function.

Note

Use the setting software to assign the reset function to the Emergency Control Input terminal. (Refer to "Emergency Control Input Settings" in "Event Settings" in the separate software instruction manual.)

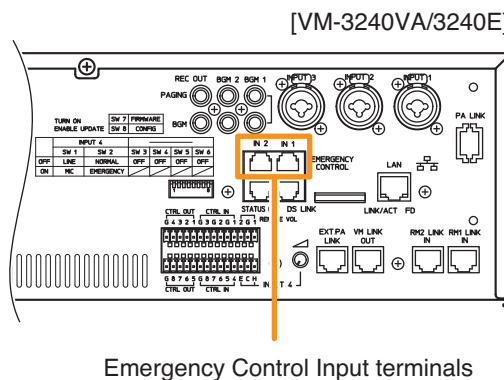

Note: This figure represents the VM-3240VA.

6.2.2. Automatic emergency announcement broadcasts

This function makes emergency broadcasts from the RM-300MF Fireman's Microphone by playing back the Alert or Evacuation announcements stored in the VM-3240VA.

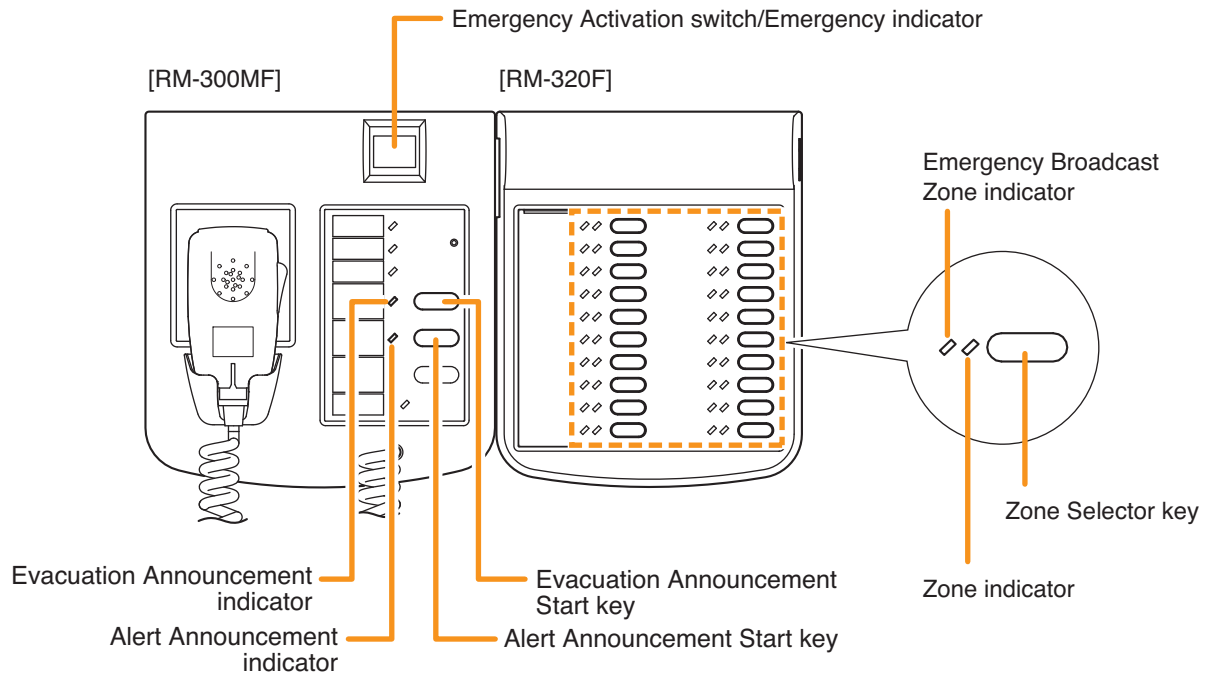

Step 1. Press the RM-300MF's Emergency Activation switch.

The Emergency indicator (Emergency Activation switch) lights red, placing the unit in emergency broadcast mode.

Step 2. Press the RM-320F Fireman's Microphone Extension's Zone Selector key(s) to select broadcast zone(s).

The selected zone's indicator lights green, indicating that emergency microphone announcements can be broadcast over the selected zone.

Notes

- The RM-320F Fireman's Microphone Extension is an optional device. If the Expansion Unit is not connected, emergency announcements are broadcast over all broadcast zones.
- Use the setting software to set the Zone Selector key. (Refer to "Emergency Control Input Settings" in "Event Settings" in the separate software instruction manual.)
- If Step 2 is skipped and the broadcast zone is not selected, emergency announcements are broadcast over all broadcast zones.

Step 3. Press either the RM-300MF's Alert or Evacuation Announcement Start key.

The Alert Announcement indicator or Evacuation Announcement indicator and the RM-320F Fireman's Microphone Extension's Emergency Output indicator both light red, broadcasting the Alert or Evacuation announcement over the selected broadcast zone(s).

Note

Holding down the Alert Announcement Start key during Alert announcements or the Evacuation Announcement Start key during Evacuation announcements for 3 seconds or more causes the announcement to be terminated and the indicator to go out.

Step 4. To terminate the emergency broadcast, reset the emergency mode using one of the following methods:

- Press the Reset key on the front panel of the VM-3240VA.

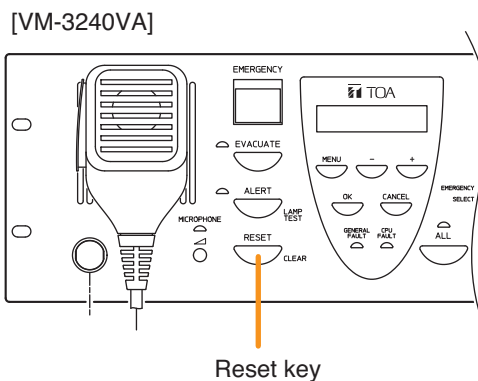

- Press the RM-300MF Fireman's Microphone Emergency Reset key.

Note

The Emergency Reset indicator (red) remains lit while the Emergency Reset key is pressed.

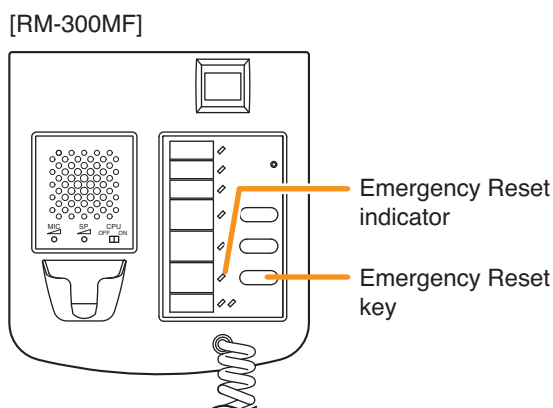

- Input a reset signal to the Emergency Control Input terminal of the VM-3240VA or VM-3240E which has been assigned a reset function.

Note

Use the setting software to assign the reset function to the Emergency Control Input terminals. (Refer to "Emergency Control Input Settings" in "Event Settings" in the separate software instruction manual.)

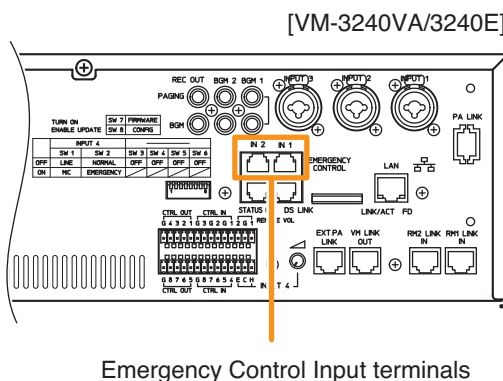

Emergency Control Input terminals

Note: This figure represents the VM-3240VA.

6.3. Making Automatic Emergency Announcements Using Control Signal Inputs (Automatic Fire Alarm Systems, etc.)

This function makes emergency broadcasts by playing back internal Alert or Evacuation announcements when the emergency control input terminals located on the rear panel of the VM-3240VA or VM-3240E receive an emergency control signal from a connected automatic fire alarm system or external equipment. These emergency announcements being broadcast can also be stopped by the control signal.

Perform the following settings in advance using the setting software:

Make settings so that the Alert or Evacuation announcement to be broadcast over the designated zone(s) when the emergency control input terminal of the VM-3240VA or VM-3240E is activated. (For more information, refer to "Emergency Control Input Settings" in "Event Settings" in the separate software instruction manual.)

[Emergency control signal entry and operation]

Step 1. An emergency control signal is input to the Emergency Control Input terminals when an automatic fire alarm system is activated.

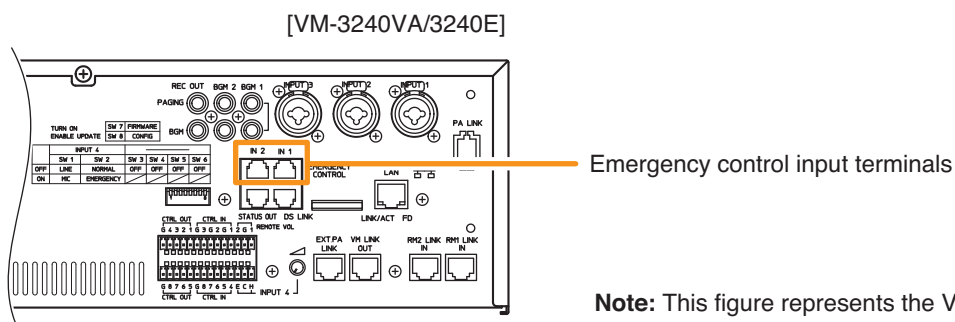

Step 2. The Alert or Evacuation announcement is broadcast over the zone(s) assigned to the Emergency Control Input terminals. The Emergency indicator flashes red, the buzzer sounds and the Alert or Evacuation Announcement indicator lights red. At the same time, the Output indicator corresponding to the set broadcast zone(s) lights.

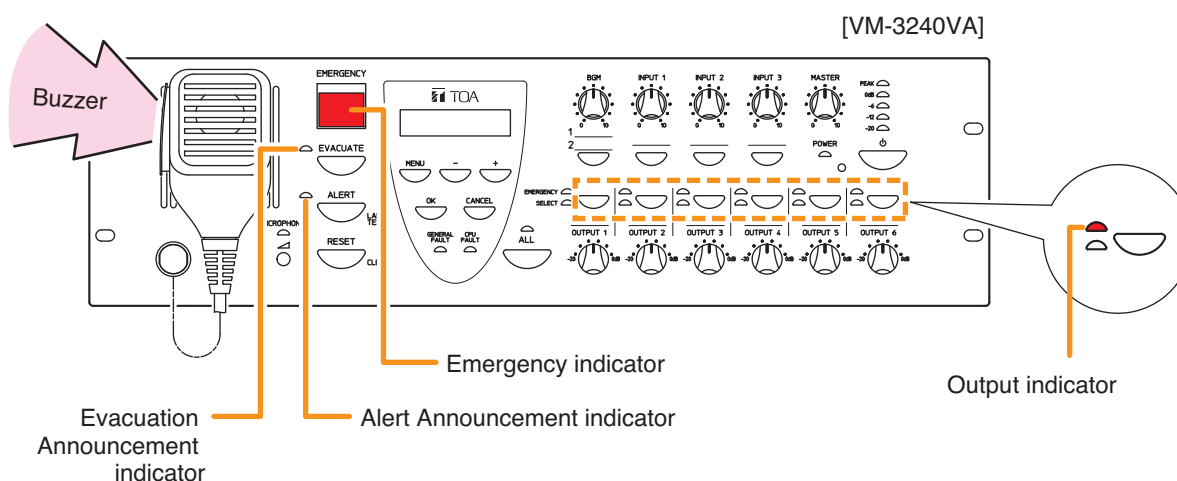

Note

Assigning a function to stop the Alert or Evacuation message announcements to the emergency control input terminals allows these announcements being broadcast to be stopped. Use the setting software to assign message stop function to the Emergency Control Input terminals. (Refer to the separate software instruction manual.)

Step 3. To terminate the emergency broadcast, reset the emergency mode using one of the following methods:

- Press the Reset key on the front panel of the VM-3240VA.

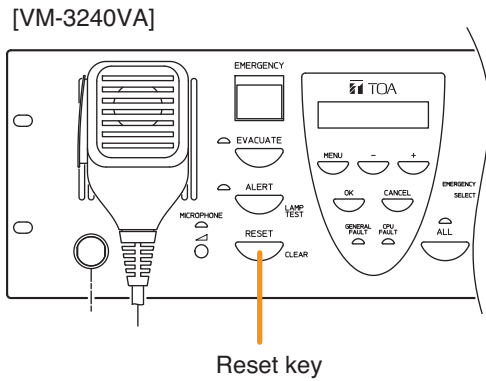

- Press the RM-300MF Fireman's Microphone Emergency Reset key.

Note

The Emergency Reset indicator (red) remains lit while the Emergency Reset key is pressed.

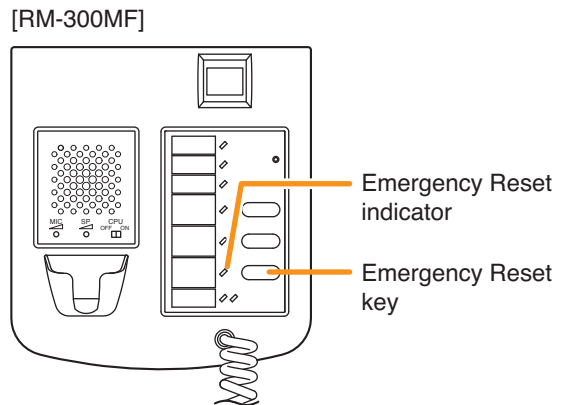

- Input a reset signal to the Emergency Control Input terminal of the VM-3240VA or VM-3240E which has been assigned a reset function.

Note

Use the setting software to assign the reset function to the Emergency Control Input terminals. (Refer to "Emergency Control Input Settings" in "Event Settings" in the separate software instruction manual.)

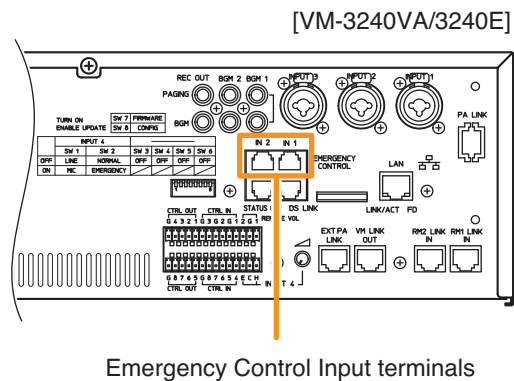

Note: This figure represents the VM-3240VA

6.4. Summary of Emergency Broadcast Procedures

6.4.1. Making emergency broadcasts from the VM-3240VA

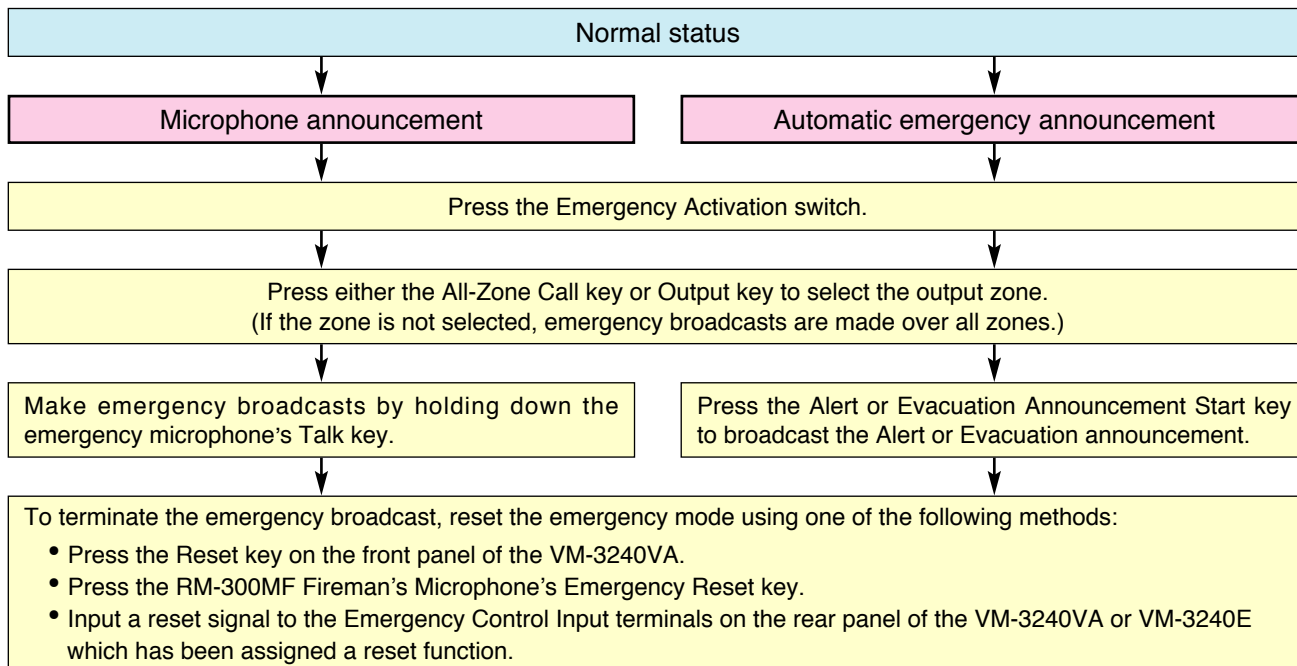

6.4.2. Fireman's microphone emergency broadcasts

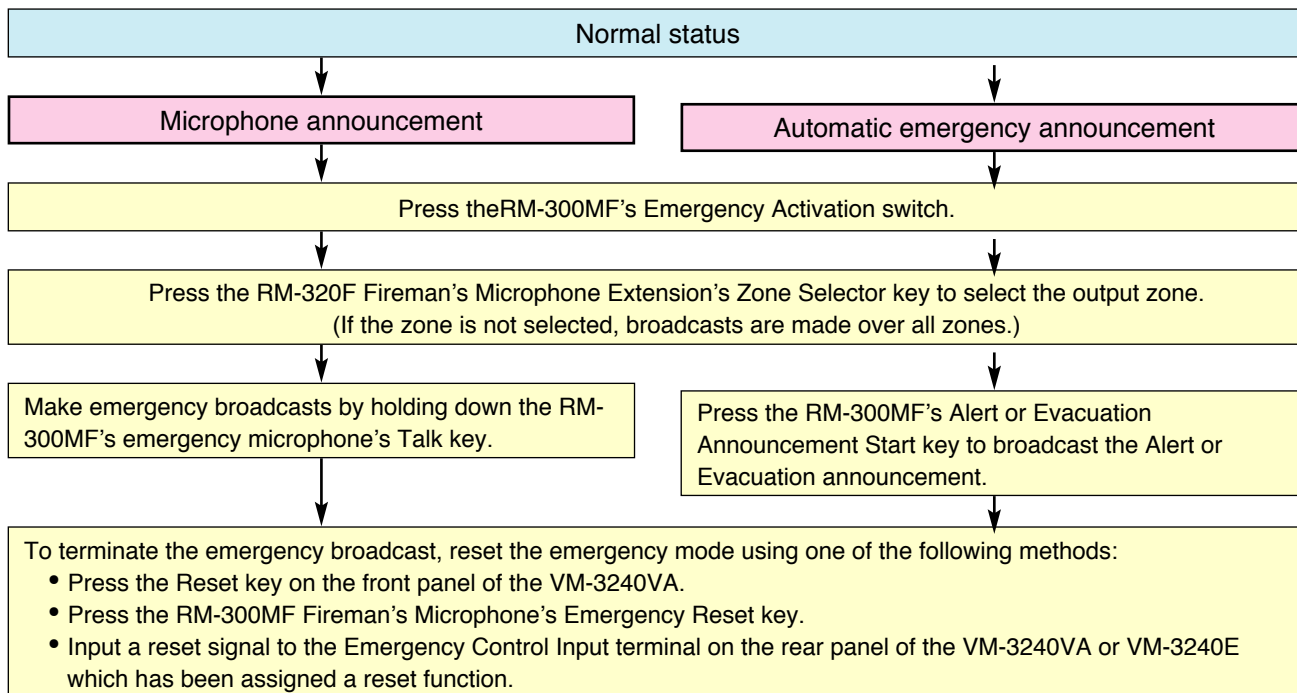

6.4.3. Making automatic emergency announcements using the control signal input

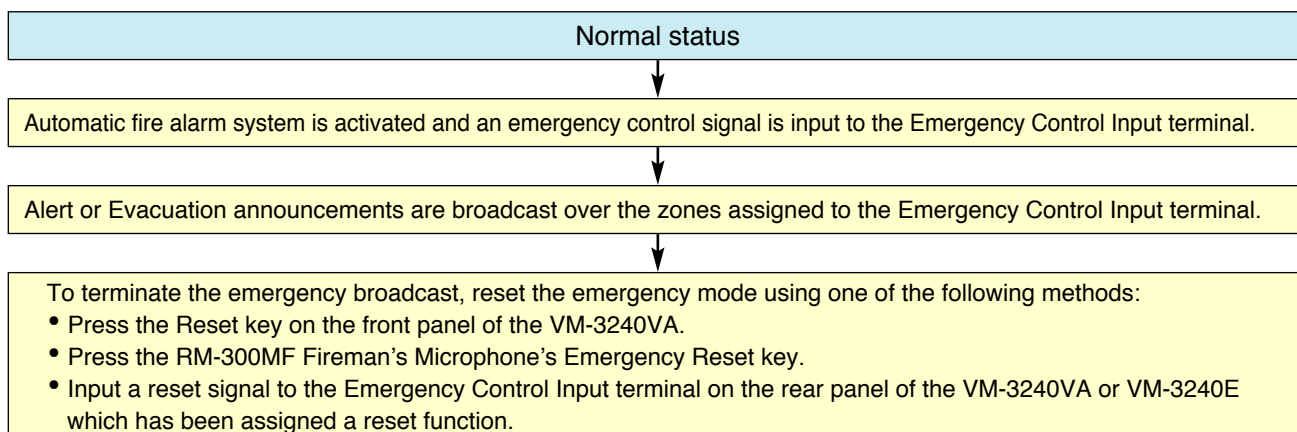

7. EQUIPMENT STATUS AND RESPONSE WHEN EMERGENCY MODE IS ACTIVATED BY EXTERNAL EQUIPMENT

Note

Enable the function for Emergency Activation switch. (For details, refer to "Emergency Control Input Settings" and "RM-300MF settings" in "Event Settings" in the separate software instruction manual.)

7.1. RM-300MF Status and Operation When Emergency-Activated by External Equipment

The Emergency indicator flashes red and the buzzer sounds. If the Emergency Activation switch is pressed, the Emergency indicator stops flashing and continuously lights red. At the same time, the buzzer stops.

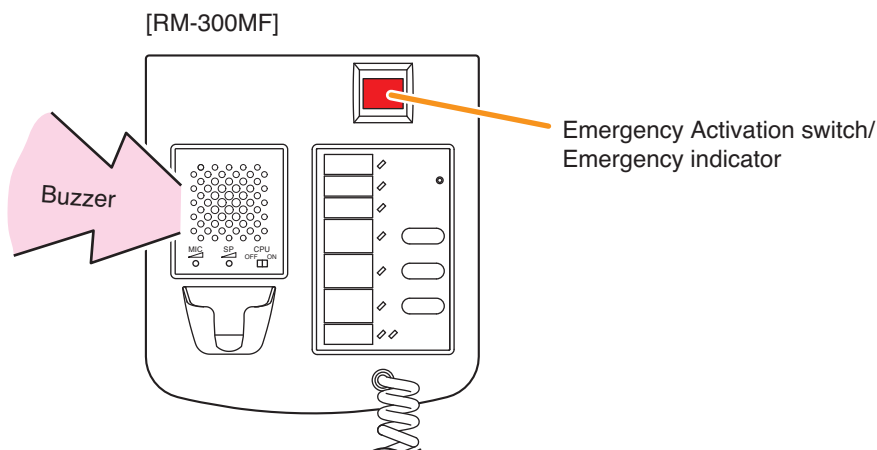

7.2. VM-3240VA Status and Operation When Emergency-Activated by External Equipment

The Emergency indicator flashes red and the buzzer sounds. If the Emergency Activation switch is pressed, the Emergency indicator stops flashing red and continuously lights red. At the same time, the buzzer stops.

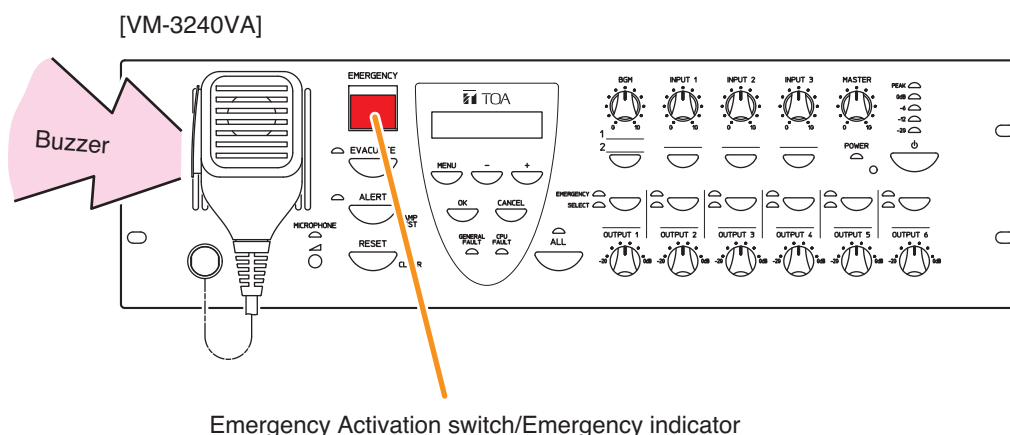

7.3. When Emergency-Activated by External Contact Input from Automatic Fire Alarm Systems, etc.

- VM-3240VA: The Emergency indicator flashes red and the buzzer sounds.
- RM-300MF: The Emergency indicator flashes red and the buzzer sounds.

If the Emergency Activation switch of each device is pressed, the Emergency indicator stops flashing red and continuously lights red. At the same time, the buzzer stops.

8. PRIORITY SETTINGS

8.1. General Broadcast Priorities

In general broadcasts, priorities can be set to the VM-3240VA's input source and the VM-3240E's local input source. Following are such priority-assignable inputs or sound sources: INPUT 1 – 4 (audio input), BGM 1 & 2 (BGM input), RM 1 & 2 LINK IN (remote microphone input), internal automatic general announcements 1 – 6, and Local INPUT (audio input).

Priority levels can be set on the setting software. (Refer to "Priority Settings" in the separate software instruction manual.)

- The lower the number, the higher the priority. Priorities that can be set differ depending on the connected terminal.

Input Terminal (Sound Source)	Priorities
Inputs 1 – 4 (audio)	1 – 6 and 7 (MIX)
BGM 1 & 2 (BGM)	8 (BGM)
RM 1&2 LINK IN (remote microphone)	1 – 6
Automatic announcements 1 – 6 (Internal sound source)	1 – 6
Local Input	1 – 6

- While a broadcast with Priority 1 – 6 is being made, if another broadcast with higher priority is made, the lower priority broadcast is interrupted. When multiple broadcasts with the same priority are simultaneously made, the latest broadcast takes precedence (default: last-in-first-out priority). This priority can be changed to a first-in-first-out arrangement through software settings. The original broadcast is restored after the priority broadcast is complete.
- Priority 7 can be assigned only to Inputs 1 – 4 (audio input). Setting these inputs to Priority 7 (MIX) allows them to be used as BGM source inputs. If two or more of these inputs are set to Priority 7, their sound source outputs are mixed.
- Priority 8 can be assigned only to BGM 1 & 2 (BGM input). If broadcast with Priority 1 – 7 is started during BGM (Priority 8) playback, the BGM is temporarily attenuated to allow the broadcast with Priority 1 – 7 to go through. The original BGM playback is restored when the priority broadcast is complete.
- When multiple input sound sources are simultaneously broadcast, the Output indicator indicates the input sound source with the highest priority.
- Depending upon priorities set to each input terminal (sound source), operations of the internal attenuator (speaker output volume control), external attenuator and master volume control differ.

Priority	Internal ATT.	External ATT.	Master volume
1, 2	Bypass	Bypass	Bypass
3, 4	Bypass	Enable	Bypass
5, 6	Bypass	Enable	Enable
7 (MIX)	Enable	Enable	Enable
8 (BGM)	Enable	Enable	Enable

Differences in System Operation Due to "System Type" Settings When Priority Broadcasts Are Made

[In a 1-channel broadcast system]

When another higher priority broadcast is started during a broadcast, if broadcast areas for the two are different, the original broadcast is cut off in areas other than those where the higher priority broadcast has been made.

[In a BGM/Paging broadcast system]

Priorities 1 – 6 are assigned to paging calls made by the VP series standby amplifiers, while Priorities 7 (MIX) and 8 (BGM) are for BGM broadcasts made by the VM-3000 series Amplifiers. When another broadcast with priority 1 – 6 is made during a broadcast with priority 7 or 8, if broadcast areas for the two are different, the original broadcast is maintained in areas other than those where the latest broadcast has been made.

8.2. Emergency Broadcast Priorities

Priorities for emergency broadcasts are assigned to the following announcements: microphone announcements from VM-3240VA, microphone announcements from the RM-300MF, and Alert/Evacuation announcements. (Priorities are fixed.)

The lower the number, the higher the priority.

Sound Source	Priorities (fixed)
Microphone announcement by RM-300MF/ID1 (RM-300MF assigned to ID1 using the setting software)	1
VM-3240VA Microphone Announcement	2
Microphone announcement by RM-300MF/ID2 (RM-300MF assigned to ID2 using the setting software)	3
Evacuate EV (internal pre-recorded Evacuation message)	4
Alert EV (internal pre-recorded Alert message)	5

The internal attenuator (speaker output volume control), external attenuator and master volume control cannot be used during emergency broadcasts.

9. CPU OFF FUNCTION

9.1. What Is the CPU OFF Function?

The CPU OFF function bypasses the CPU*, which the VM-3000 system uses in ordinary broadcasts, and allows all-zone calls to be made from the VM-3240VA or RM-300MF. Use this function when ordinary broadcasts cannot be made due to system failures, etc.

* A signal processing unit installed in the VM-3240VA or VM-3240E and RM-300MF.

9.2. Making All-Zone Calls Using the CPU OFF Function

9.2.1. Making all-zone calls from the VM-3240VA

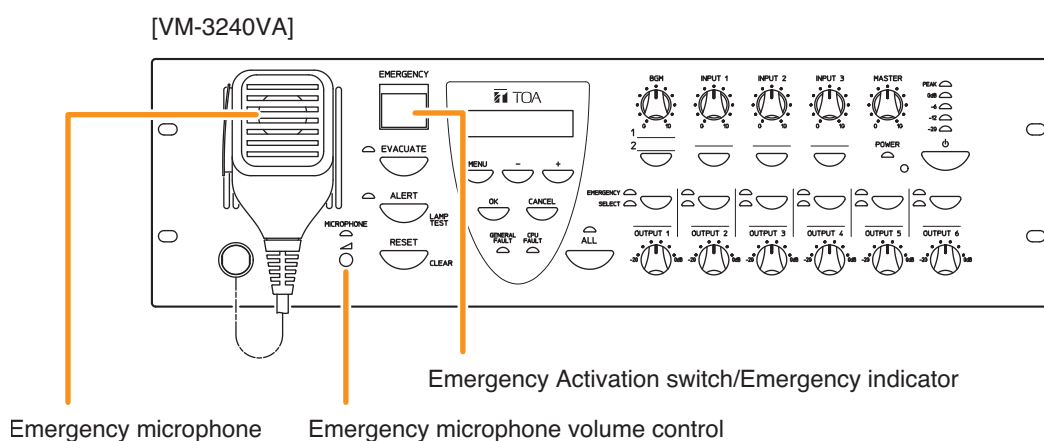

While the Emergency Activation switch on the front panel of the VM-3240VA and the Emergency Microphone's Talk key are simultaneously held down, the Emergency indicator (red) remains lit and the amplifier is placed in CPU OFF condition, allowing all-zone calls to be made from the Emergency Microphone. Adjust the sound volume with the Emergency Microphone's volume control.

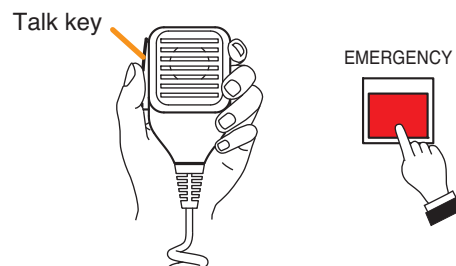

9.2.2. Making all-zone calls from the RM-300MF using the CPU OFF function

Set DIP switch 8 on the RM-300MF's bottom surface to the ON position to use the CPU OFF function. Setting the RM-300MF's front-mounted CPU ON/OFF switch to the OFF position causes the CPU OFF indicator to light red, placing the unit in CPU OFF mode. Pressing the Emergency Microphone's Talk key allows all-zone calls to be made from the Emergency Microphone. Adjust the sound volume with the microphone volume control.

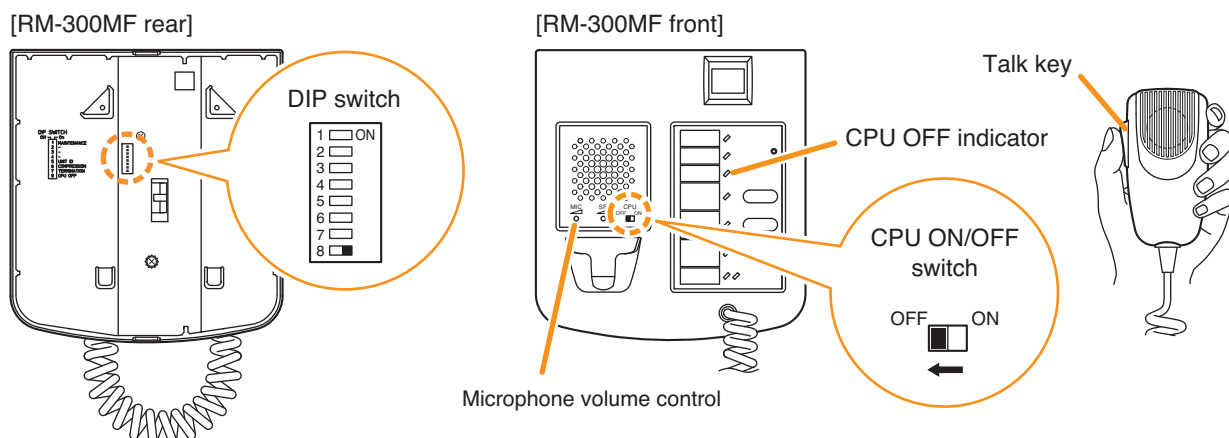

9.3. Priorities When All-Zone Calls Are Made Using the CPU OFF Function

Priorities of all-zone calls using the CPU OFF function differ depending on the input terminal to which the RM-300MF is connected. Connect the RM-300MF to the VM-3240VA's RM1 LINK or RM2 LINK connector.

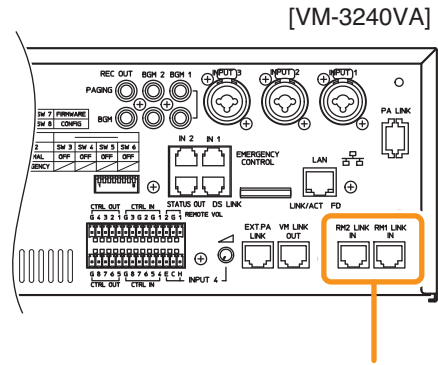

Remote microphone link connectors

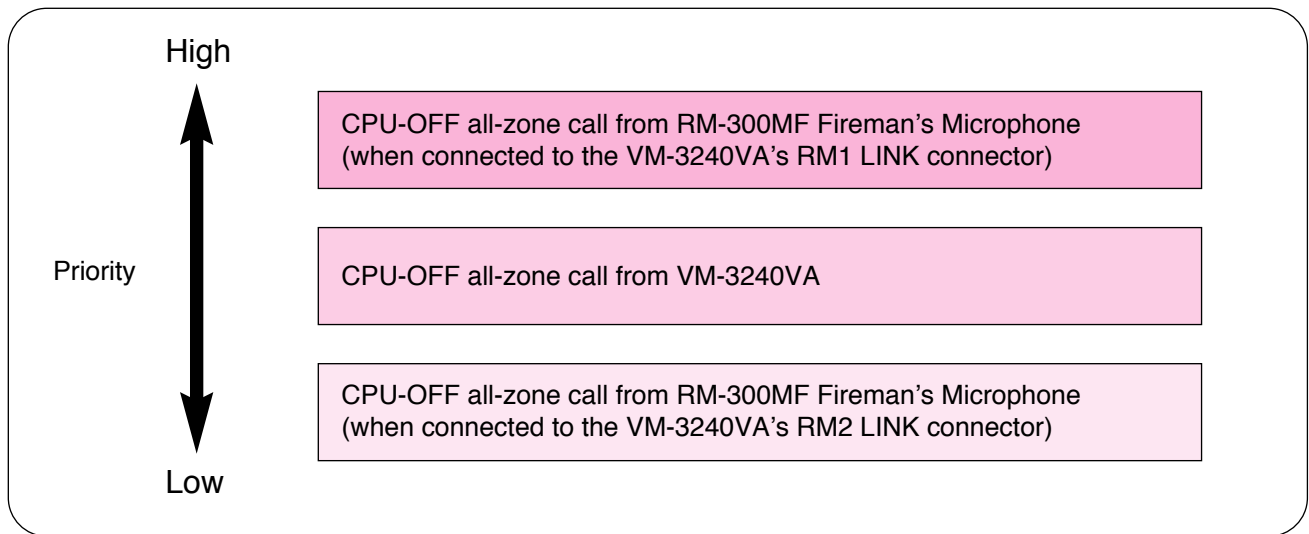

10. SURVEILLANCE

10.1. What Is the Surveillance Function?

The surveillance function continually monitors operating conditions for each piece of equipment in the system, operations between equipment components, connections and communications between equipment components, power supply conditions and other important component parts and points extending from input to output. If malfunctions or cable breakage is detected, details of such irregularities* are displayed on the VM-3240VA's LCD. At the same time, the communications failure indicator or failure indicator on the system equipment flashes to alert the system operator to such irregularities along with a buzzer tone.

The setting software is used to set surveillance time intervals, component parts to be monitored and subsequent operations when a failure is detected. (Refer to "Surveillance Settings" in the separate software instruction manual.)

Detected failures are recorded in the VM-3240VA's log, and the recorded log can be confirmed using the setting software. (Refer to "Log Display" in the separate software instruction manual.)

* For LCD failure display, refer to [page 60](#).

10.2. How to Use the Surveillance Function

Be sure to perform the following settings to enable the surveillance function. If not performed, the surveillance function cannot be used.

- Initialize surveillance settings using the setting menu displayed on the VM-3240VA's LCD. (Refer to "[Surveillance Settings](#)" on [page 84](#).)

Note

Be sure to perform this initialization after completing the system installation and connections.

- Use the setting software to set the surveillance function. (Refer to "Surveillance Settings" in the separate software instruction manual.)

10.3. Monitored VM-3000 System Components

Shown below are the monitored component parts and points:

- VM-3240VA
- Automatic emergency announcement
- Expansion amplifier (VM-3240E)
- Emergency remote microphone (RM-300MF)
- Battery
- Speaker (short or open circuit)
- Speaker (ground fault)
- Charging device (VX-2000DS)
- Emergency control terminal
- General-use remote microphone (RM-200M)
- Extension amplifier (VP-2241)
- Standby amplifier (VP-2241)

Using the setting software, enable or disable settings individually for each of the above items. (Refer to "Surveillance Settings" in the separate software instruction manual.)

Tip

Each of the above items can be registered into up to 64 groups. (Refer to "RM-300MF settings" in "Event Settings" in the separate software instruction manual.)

10.4. Equipment Operation upon Failure Detection and Recovery Procedure

If any malfunction is detected within the system, the buzzer sounds, the failure indicator flashes and failure information* is displayed on the VM-3240VA's LCD screen. The operations of other system equipment differ when a communications error or other failures occur. The following are rough guidelines on actions to take after such failures have been detected.

The procedure for recovery from irregularities other than communications failures is:

1. Perform failure acknowledgment.
2. Remedy the cause.
3. Perform failure reset.

Recovering from communications failures:

When a failure is detected in communications between an individual component and the VM-3240VA, component operation can no longer be performed. First, remedy the cause of the failure. If communication returns to normal, the original condition will automatically be restored.

* For LCD failure display, refer to [page 60](#).

10.4.1. Equipment operation upon failure detection

[VM-3240VA]

Equipment operation upon failure detection

The buzzer sounds, the failure indicator flashes yellow and failure information is displayed on the LCD screen.

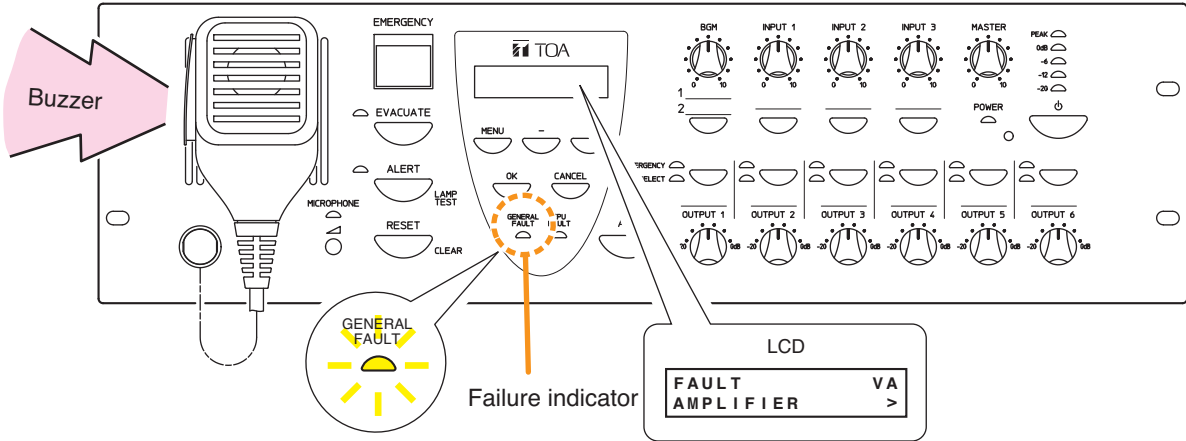

In this event, a failure of the contents shown on the LCD screen has occurred within the system. Pressing the amplifier's [OK] key to acknowledge the failure or acknowledging the failure by way of the Fireman's Microphone stops the buzzer and switches the yellow failure indicator from flashing to steady-on mode. (Refer to "Failure Acknowledgement" on [page 54](#)).

If the failure is reset at the amplifier, the failure indicator goes out. However, if the cause of the failure has not been remedied, the unit will return to failure status. (Refer to "Failure Reset Operation" on [page 55](#)).

[VM-3240E]

Equipment operation upon failure detection

The Communications Failure indicator flashes yellow.

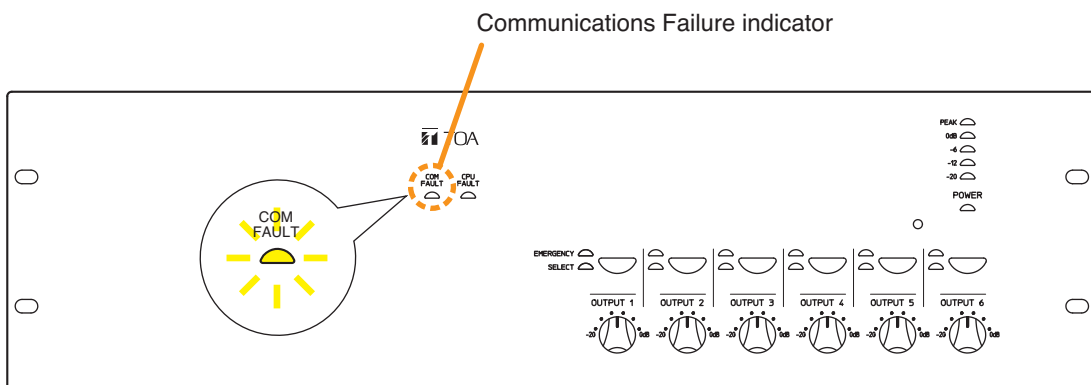

A failure has occurred in communications between the unit and the VM-3240VA. The previous status is automatically restored if communications return to normal.

[RM-300MF and RM-320F]

Equipment operation upon failure detection (1)

The buzzer sounds and the Failure indicator flashes yellow.

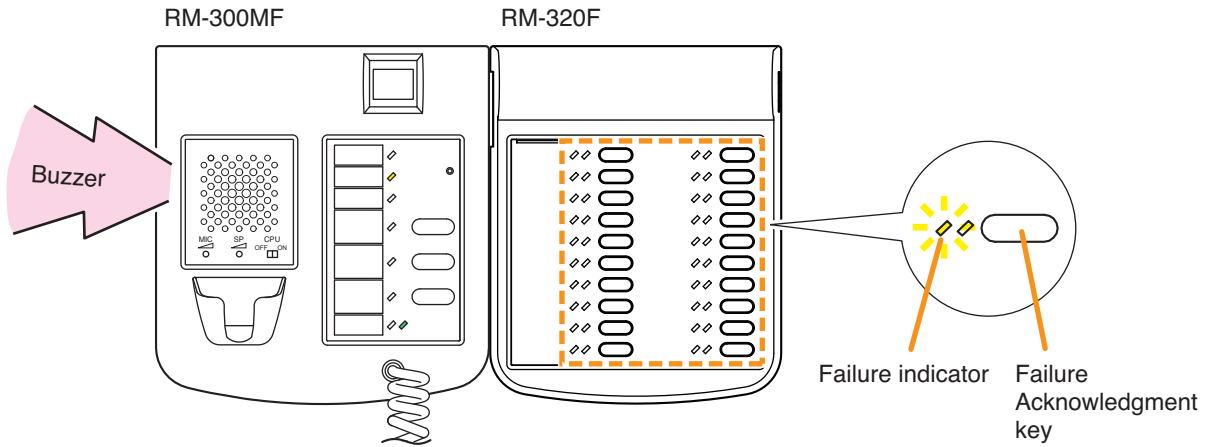

In this event, a failure not related to communications has occurred within the system. If the failure is acknowledged by any system component, the buzzer stops and the yellow Failure indicator light switches from flashing to steady on mode. (Refer to "Failure Acknowledgement" on page 54). Resetting the failure at the VM-3240VA causes the Failure indicator to go out. However, if the cause of the failure has not been remedied, the unit will again return to failure status. (Refer to "Failure Reset Operation" on page 55).

Note

The function of acknowledging the specified failure must be assigned to the RM-320F's key in advance using the setting software. (Refer to "Event Settings" -> "RM Function Key Settings" -> "RM-320F Settings" in the separate software instruction manual.)

Equipment operation upon failure detection (2)

The Communications Failure indicator flashes yellow.

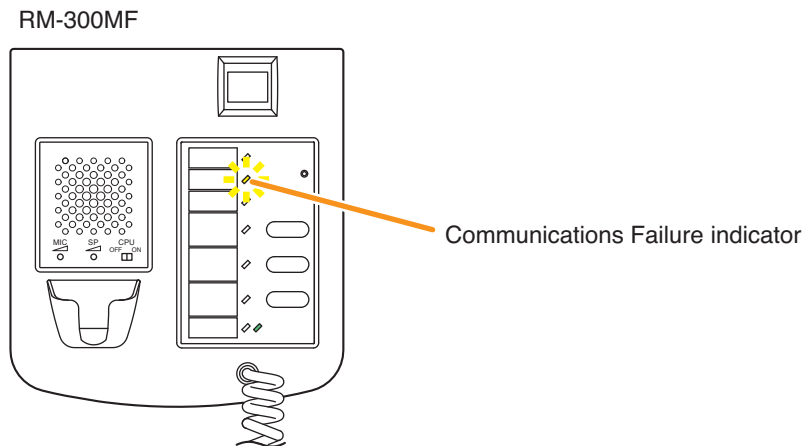

A failure has occurred in communications between the RM-300MF and the VM-3240VA. The previous status is automatically restored if communications return to normal.

[RM-200M]

Equipment Operation Upon Failure Detection

The Communications Failure indicator flashes yellow.

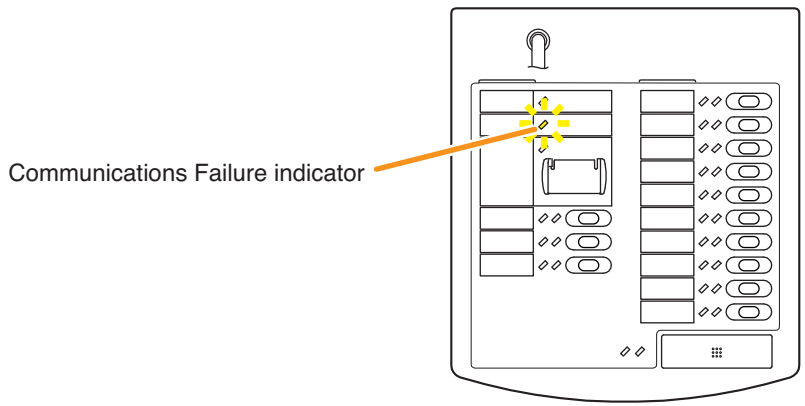

A failure has occurred in communications between the RM-200M and the VM-3240VA. The previous status is automatically restored if communications return to normal.

10.4.2. Failure acknowledgment

Perform failure acknowledgment at the VM-3240VA or RM-320F, or by use of the control input. Acknowledging a failure causes all currently sounding buzzers to stop. At the same time, the flashing yellow Failure indicator on the VM-3240VA or RM-320F will switch to steady on mode.

Note

Only the Failure indicator is switched from flashing to steady on mode when failures are acknowledged. The Communications Failure indicator that flashes when a communications-related failure occurs will remain flashing.

[Acknowledging failures at the VM-3240VA]

Press the [OK] key.

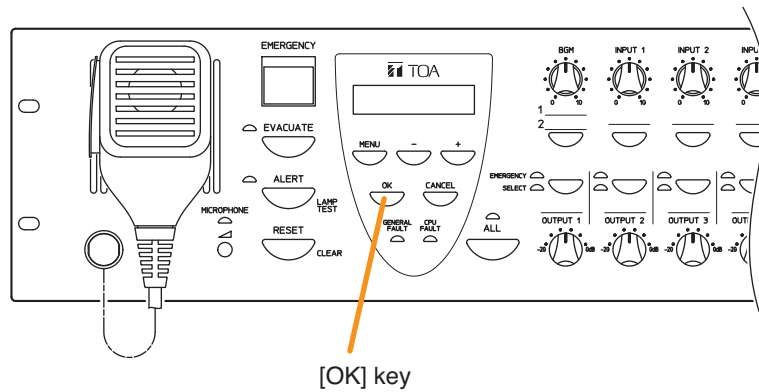

[Acknowledging failures at the RM-320F]

Press the Failure Acknowledgment key corresponding to the yellow flashing Failure indicator.

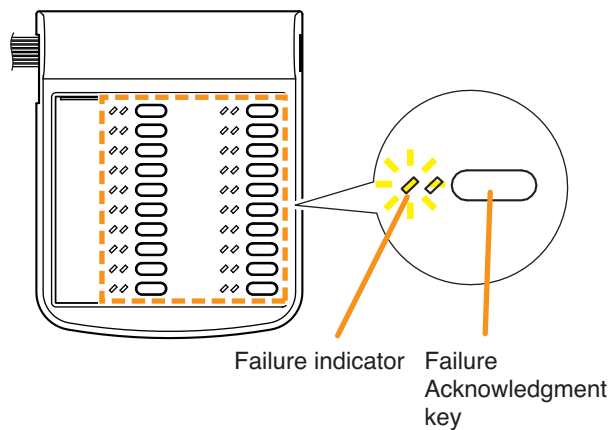

Notes

- The "Failure Acknowledgment" function must be assigned to the key in advance. If this function is not assigned, the RM-320F cannot be used for failure acknowledgment.
- The acknowledgment function can be assigned using the setting software. (Refer to "Event Settings" → "RM Function Key Settings" → "RM-320F Settings" in the separate software instruction manual.)

[Acknowledging failures by the control input]

Failure acknowledgment can also be performed by using the control inputs of the VM-3240VA and VM-3240E. (Refer to "Event Settings" → "General Control Input Settings" in the separate software instruction manual.)

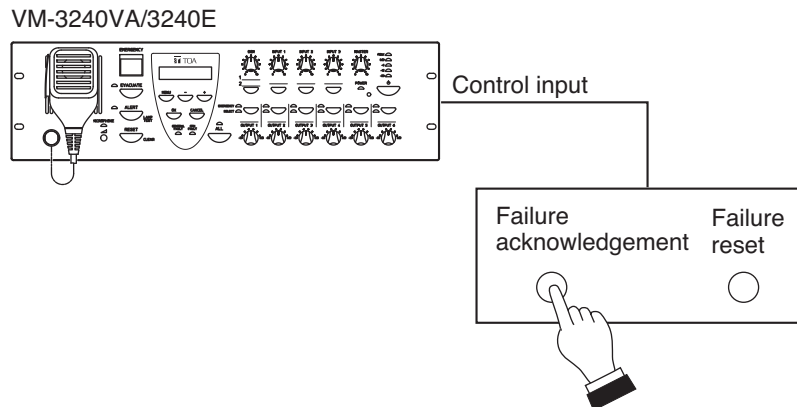

10.4.3. Failure reset operation

Perform failure reset at the VM-3240VA or RM-320F, or by use of the control input. Resetting failures causes all currently lit or flashing yellow Failure and Communications Failure indicators to go out and returns the system to normal status. However, if the cause of the failure has not been remedied, the system will again return to failure mode.

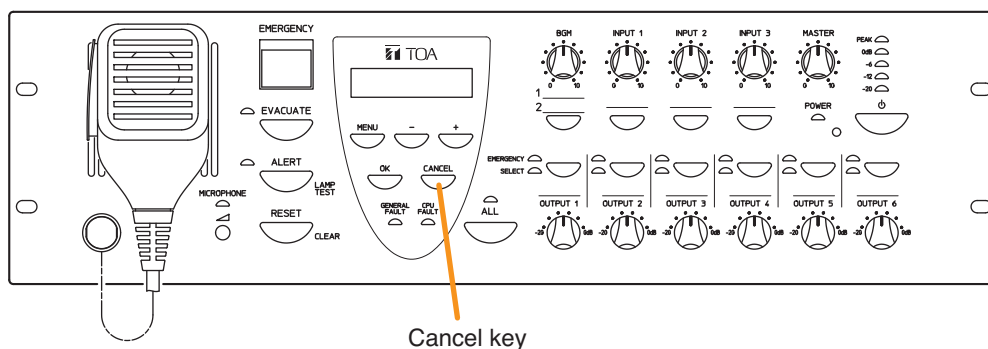

[Resetting failures at the RM-320F]

Press the Failure Reset key.
The Failure Reset indicator remains lit while the key is held down.

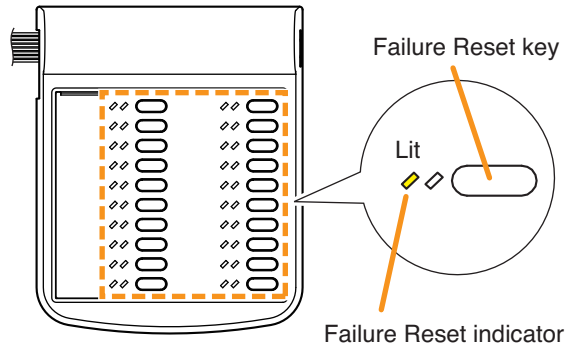

Notes

- The "Failure Reset" function must be assigned to the key in advance. If this function is not assigned, the RM-320F cannot be used for failure reset.
- The Failure Reset function can be assigned using the setting software. (Refer to "Event Settings" → "RM Function Key Settings" → "RM-320F Settings" in the separate software instruction manual.)

[Resetting failures by the control input]

Failure reset can also be performed by using the control inputs of the VM-3240VA and VM-3240E. (Refer to "Event Settings" → "General Control Input Settings" in the separate software instruction manual.)

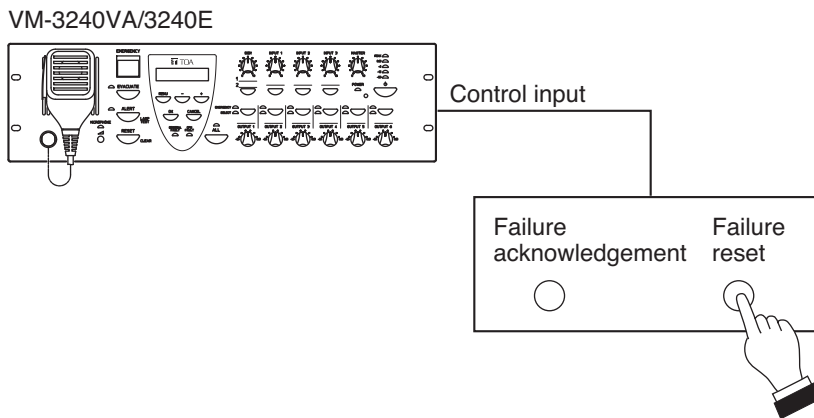

10.5. Examples of Failures and Their Counter-Operations

Procedures for acknowledging and resetting failures are explained here.

10.5.1. Failure example 1: Communications failure

Assuming that the RM-300MF's connection is disconnected within the VM-3000 system, when the failure is detected, the equipment operates as follows:

VM-3240VA	The buzzer sounds, the Failure indicator flashes yellow and failure information is displayed on the LCD screen.
RM-300MF	The Communications Failure indicator flashes yellow.

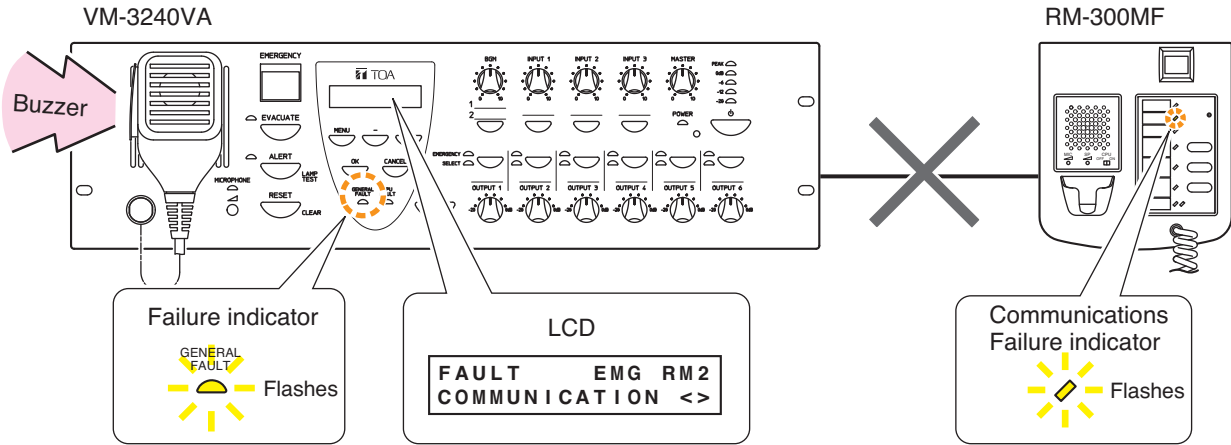

[Operation examples when a failure occurs]

Note

The RM-300MF cannot be used.

- Step 1.** Press the VM-3240VA's [OK] key (to acknowledge the failure).
The buzzer stops and the yellow Failure indicator light switches from flashing to steady on mode.

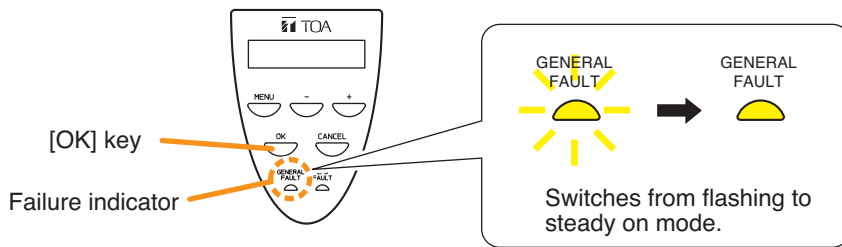

- Step 2.** Determine the cause and remedy it.
Then correctly reconnect the cables between the RM-300MF and the VM-3240VA.

- Step 3.** If communications are restored, the system automatically returns to the previous status, causing the VM-3240VA's Failure indicator and the RM-300MF's Communications Failure indicator to go out.

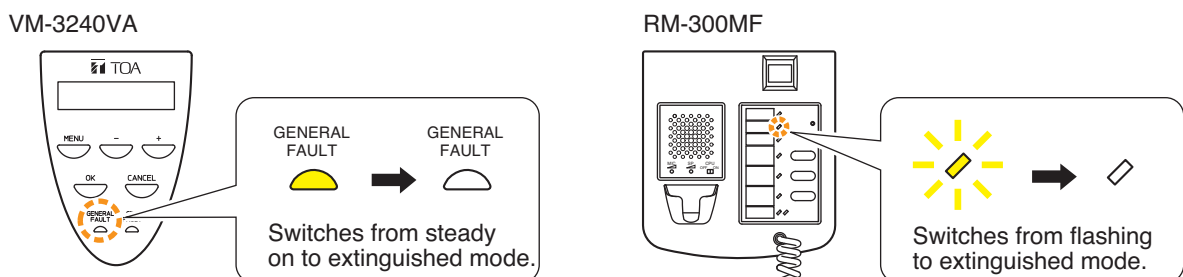

10.5.2. Failure example 2: Short circuit of speaker line 6

Assuming that Speaker Line 6 connected to the VM-3240VA is shorted, when the failure is detected, the equipment operates as follows.

VM-3240VA	The buzzer sounds, the Failure indicator flashes yellow and failure information is displayed on the LCD screen.
RM-300MF and RM-320F	The buzzer sounds and the Failure indicator flashes yellow.

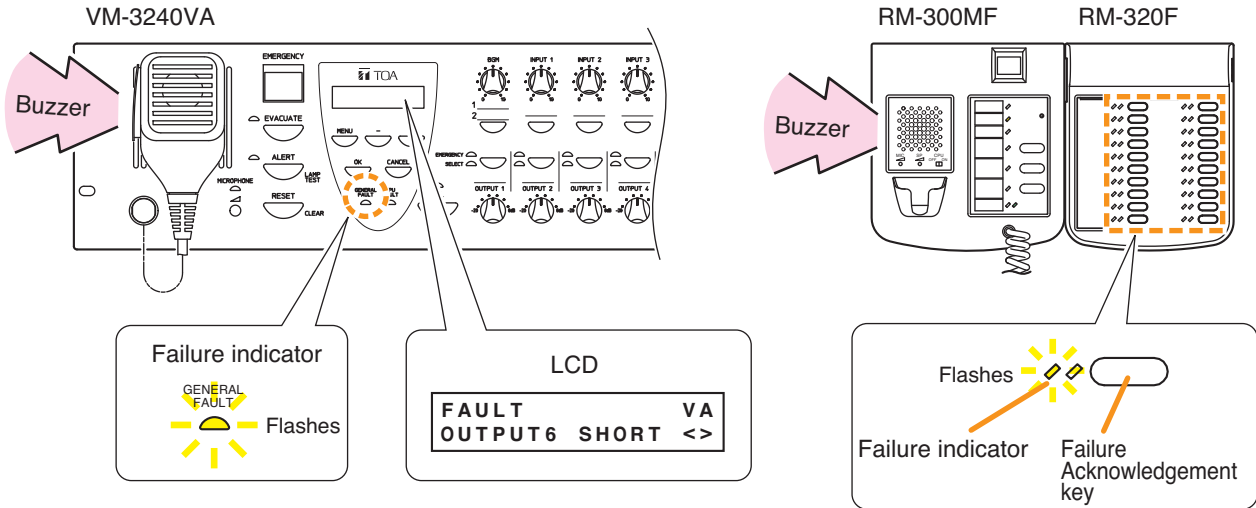

Note

The function of acknowledging speaker short circuit failures must be assigned to the Failure Acknowledgement key. If this function is not assigned, failures cannot be acknowledged by the RM-320F. Use the setting software to assign the failure acknowledgement function. (Refer to "Event Settings" → "RM Function Key Settings" → "RM-320F Settings" in the separate software instruction manual.)

[Operation example when a failure occurs]

Step 1. Press either the VM-3240VA's [OK] key (to acknowledge the failure) or the RM-320F's [Failure Acknowledgment] key. The buzzers on the VM-3240VA and the RM-320F stop and the yellow Failure indicators on the VM-3240VA and RM-320F switch from flashing to steady on mode.

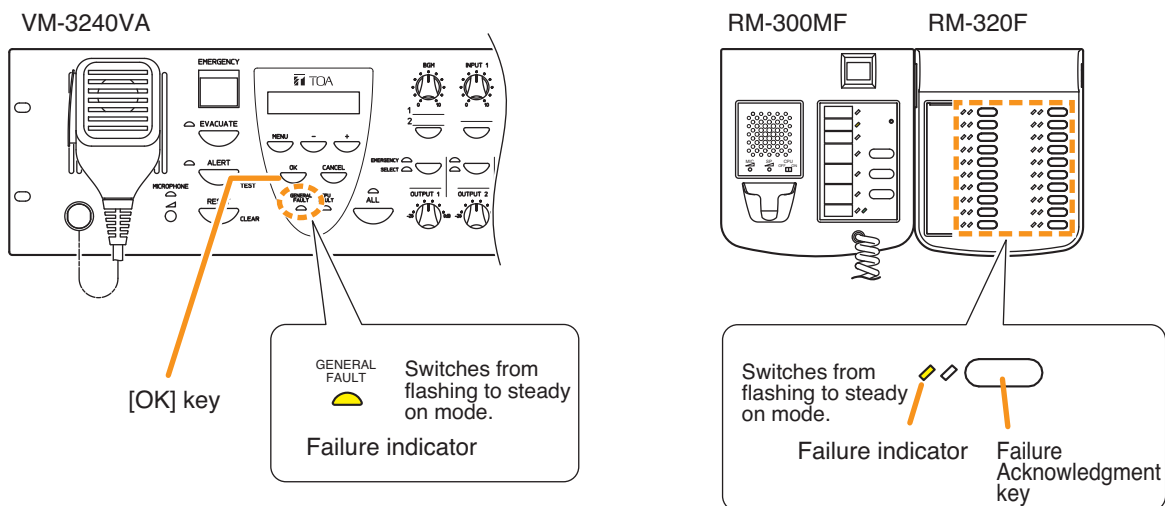

Step 2. Determine and remedy the cause.

If the cause cannot be determined from the VM-3240VA's on-screen display, connect a PC and load the log data using the setting software. (For log data loading, refer to "Log Display" in the separate software instruction manual.)

Step 3. Press the VM-3240VA's [CANCEL] key (to reset the failure).

The Failure indicators on the VM-3240VA and the RM-320F go out, allowing normal system operation to be restored.

Note

The "Failure Reset" function must be assigned to the Failure Rest key in advance. If this function is not assigned, the RM-320F cannot be used for failure reset.

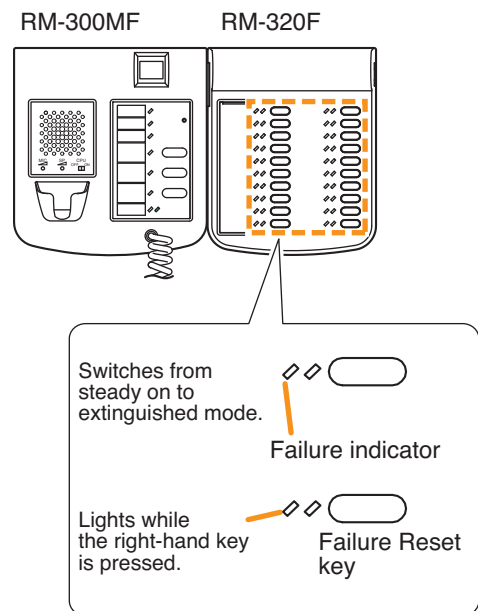
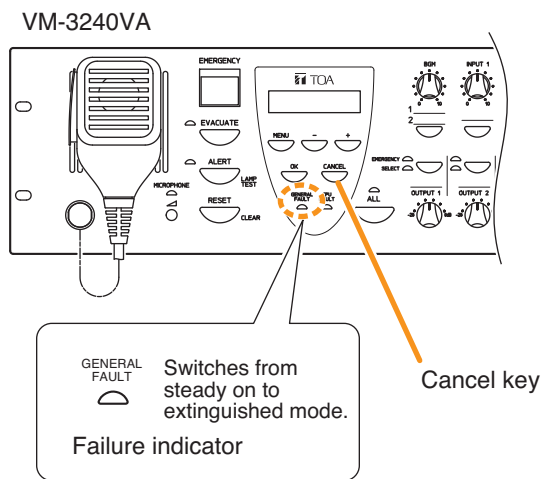

10.6. LCD Failure Display

If a failure occurs, its information, including the failure point, is displayed on the VM-3240VA's front panel-mounted LCD screen.

In this event, the display alternates between "Failure information" and "BGM status." Pressing the OK key sets the display to "Failure status."

The latest information is displayed on the LCD screen.

The ">" indication is displayed if failures occurred before the currently displayed failure, and the "<" indication is displayed if failures occurred after the currently displayed failure.

To confirm other failures not displayed on the screen, move the display using the [+] or [-] key.

Indicates the occurrence of a failure.

FAULT
AMPLIFIER

Indicates the content of the failure.

Indicates the point where the failure occurred.
The red number represents a variable part.

E 1
<>

Indicates other failures that occurred before the displayed failure.
Use the [+] key to move the screen.

Indicates other failures that occurred after the displayed failure.
Use the [-] key to move the screen.

Failure Location: Voice Alarm System Amplifier (VM-3240VA)

FAULT AMPLIFIER	VA >	The VM-3240VA has overheated or its fuse has blown.
----------------------------------	--------------------------	---

FAULT AUDIO LINE	VA <>	Failure detected in the VM-3240VA's audio lines.
-----------------------------------	------------------------------	--

FAULT MICROPHONE	VA <	Failure detected in the VM-3240VA's front panel-mounted emergency microphone.
-----------------------------------	--------------------------	---

FAULT TALK SW	VA <>	Failure detected in the talk switch of the VM-3240VA's front panel-mounted emergency microphone.
--------------------------------	------------------------------	--

FAULT SETTING DATA	VA >	Failure detected in the VM-3240VA's set files.
-------------------------------------	--------------------------	--

FAULT LOG DATA	VA >	Failure detected in the VM-3240VA's log files.
---------------------------------	--------------------------	--

FAULT EMERGENCY SW	VA >	Failure detected in the VM-3240VA's Emergency Activation switch.
-------------------------------------	--------------------------	--

FAULT POWER	VA <>	Failure detected in the VM-3240VA's power supply.
------------------------------	------------------------------	---

Failure Location: Automatic Emergency Announcement

FAULT	VA
EMERGENCY EV	>

Failure detected in the VM-3240VA's internal automatic emergency announcement device.

Failure Location: VM Extension Amplifier (VM-3240E)

FAULT	E 1
AMPLIFIER	>

The VM-3240E has overheated or its fuse has blown.

FAULT	E 2
AUDIO LINE	<>

Failure detected in the audio lines between the VM-3240VA and the VM-3240E.

FAULT	E 3
COMMUNICATION	<>

Failure detected in communications between the VM-3240VA and the VM-3240E.

FAULT	E 8
POWER	<>

Failure detected in the power supply of the VM-3240E.

Failure Location: Fireman's Microphone (RM-300MF)

FAULT	EMG	RM 2
AUDIO LINE		<>

Failure detected in the audio lines between the RM-300MF and the VM-3240VA.

FAULT	EMG	RM 1
MICROPHONE		<

Failure detected in the emergency microphone on the RM-300MF.

FAULT	EMG	RM 1
TALK SW		<>

Failure detected in the talk switch of the emergency microphone on the RM-300MF.

FAULT	EMG	RM 2
COMMUNICATION		<>

Failure detected in communications between the VM-3240VA and the RM-300MF.

FAULT	EMG	RM 2
EMERGENCY SW		>

Failure detected in the Emergency Activation switch on the RM-300MF.

FAULT	EMG	RM 1
POWER		<>

Failure detected in the power supply of the RM-300MF.

Failure Location: Battery

FAULT BATTERY	VA >
------------------	---------

Failure detected in the battery.

Failure Location: Speaker Line (Open or Short Circuit)

FAULT OUTPUT OPEN	VA 3 >
----------------------	-----------

Open circuit caused in speaker Line 3 of the VM-3240VA.

FAULT OUTPUT SHORT	VA 6 <>
-----------------------	------------

Speaker Line 6 of the VM-3240VA is short-circuited.

Failure Location: Speaker Line (Ground Fault)

FAULT GROUND FAULT	VA <
-----------------------	---------

Ground fault caused in a speaker connected to the VM-3240VA.

FAULT GROUND FAULT	E 1 <>
-----------------------	-----------

Ground fault caused in a speaker connected to the VM-3240E.

Failure Location: Emergency Power Supply (VX-2000DS)

FAULT DS	VA >
-------------	---------

VX-2000DS has failed or is not connected.

FAULT DS DC	E 2 >
----------------	----------

Failure detected in the VX-2000DS' DC output.

Failure Location: Emergency Control Input Terminal

FAULT E 3
EMG CTRL IN 4 >

Failure detected in the VM-3240E's emergency control input Terminal 4.

Failure Location: General-Use Remote Microphone (RM-200M)

FAULT RM 1
COMMUNICATION <>

Failure detected in communications between the RM-200M and the VM-3240VA.

Failure Location: Extension Amplifier (VP-2241)

FAULT EXT VA
AMPLIFIER >

The Extension Amplifier has overheated or its fuse has blown.

FAULT EXT E 1
AUDIO LINE <>

Failure detected in the audio lines between the VP-2241 and the VM-3240VA or the VM-3240E.

Failure Location: Standby Amplifier (VP-2241)

FAULT STANDBY
AMPLIFIER >

The Standby Amplifier has overheated or its fuse has blown.

FAULT STANDBY
AUDIO LINE <>

Failure detected in the audio lines between the VP-2241 and the VM-3240VA or the VM-3240E.

External Failure Detected by the Control Inputs

FAULT VA
EXTERNAL ERR 1 <>

Failure detected in the control input connected to the external equipment of VM-3240VA or VM-3240E.

The displayed error number indicates the control input 1 – 8 in failure state.

11. SETTINGS

Perform settings using the VM-3240VA's LCD screen.

To set, select the desired item after entering the setting mode, then advance to the corresponding screen.

Even if the setting menu screen is selected by pressing the Menu key during normal operating status, current broadcasts are not interrupted. Entering a setting screen by pressing the OK key on the setting menu screen will, however, interrupt the broadcast.

If the AC power supply is cut off during setting, all parameters currently being set will be cancelled.

11.1. Keys Used for Settings

VM-3240VA Front panel

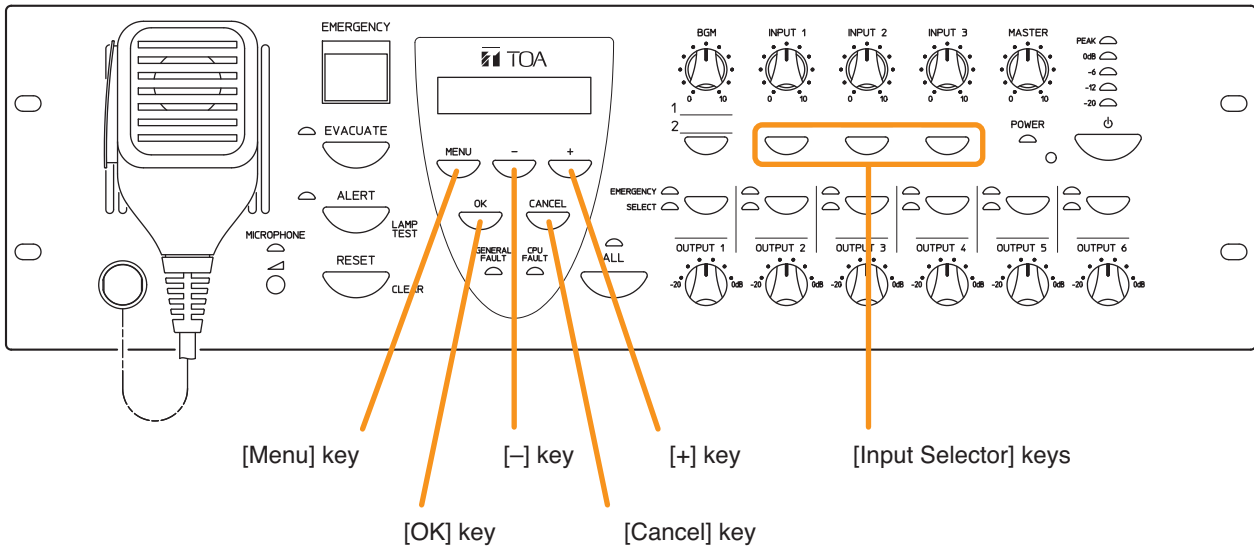

11.2. Setting Hierarchical Chart

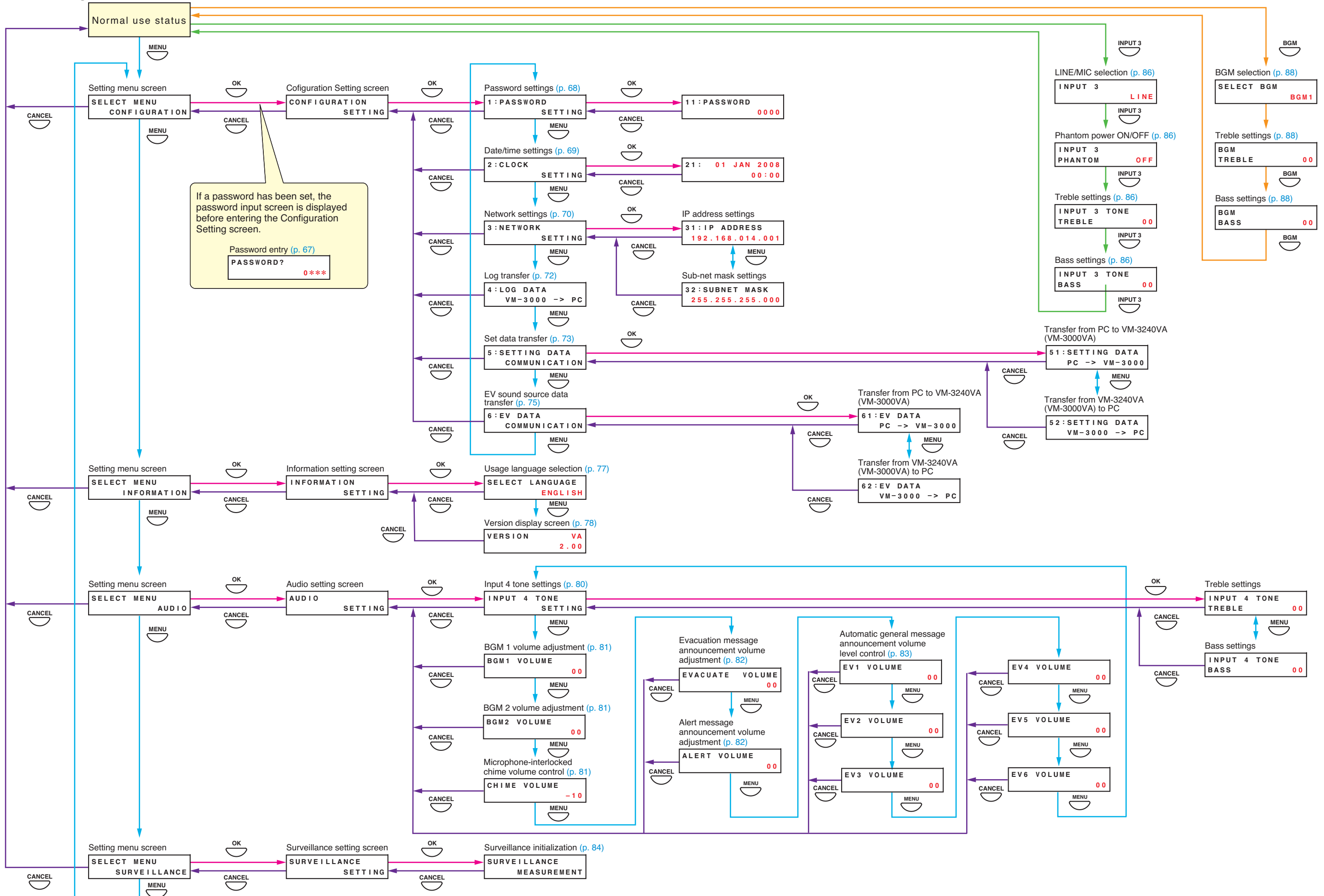

11.3. Configuration Settings

11.3.1. Configuration settings hierarchical chart

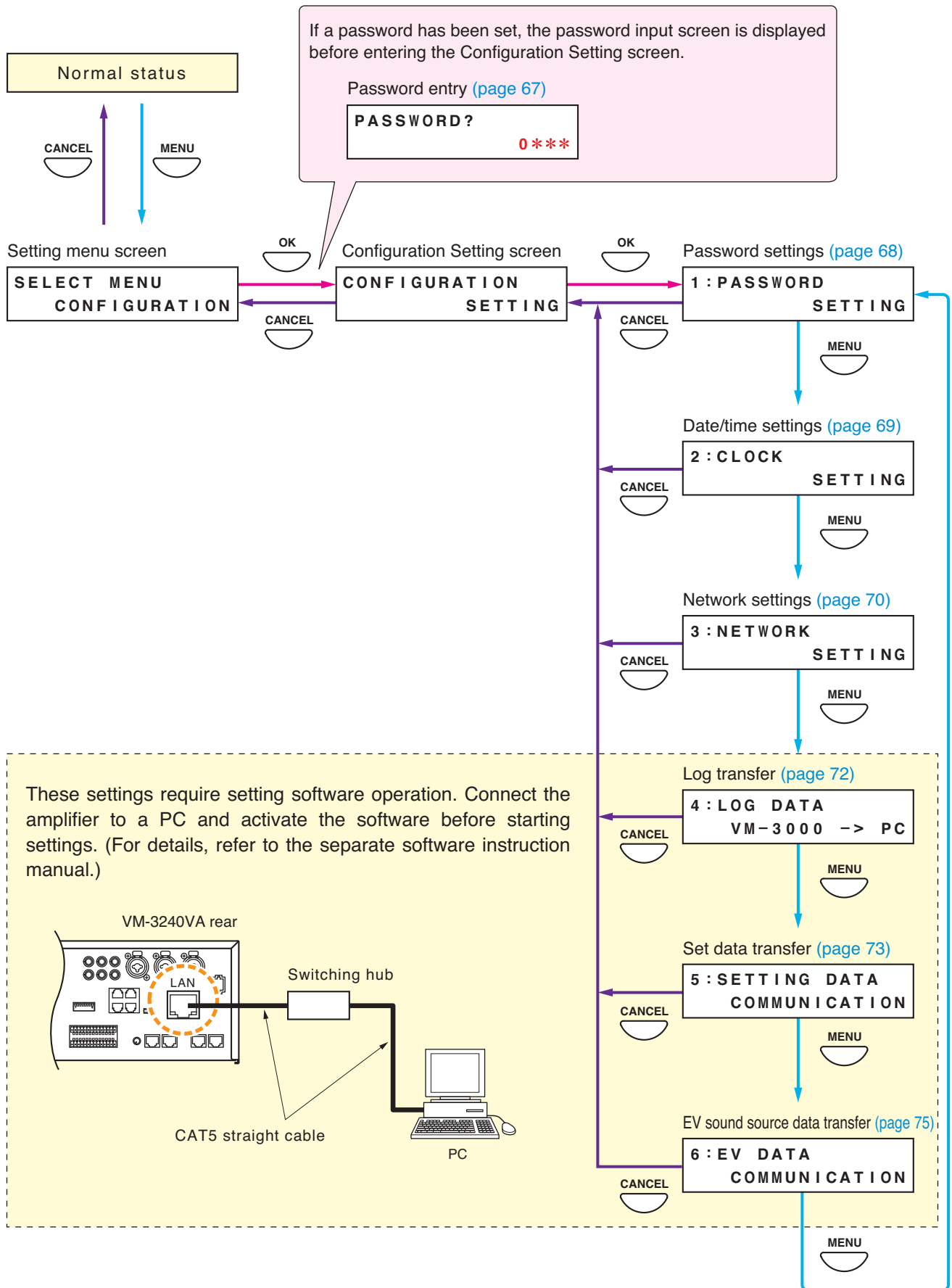

11.3.2. Password entry

If a password has been set, the password entry screen is displayed before entering the Configuration Setting screen. (For password settings, refer to [page 68](#).)

Step 1. When a password has been set, pressing the OK key on the setting menu screen displays the password input screen. (Pressing the Cancel key returns the display to the original screen.)

Step 2. Enter the password using the [+] or [-] key. The number increases as the [+] key is pressed and decreases as the [-] key is pressed. An underline () is shown at the leftmost digit to indicate entry position.

Step 3. Press the OK key. The underline moves to the next digit (to the right). (Pressing the Cancel key moves the display one screen back.)

Step 4. Repeat Steps 2 and 3 to complete a 4-digit number.

Step 5. Press the OK key when the underline is at the fourth digit. If the entered password is correct, the display switches to the Configuration Setting screen. If incorrect, the display returns to the password entry screen.

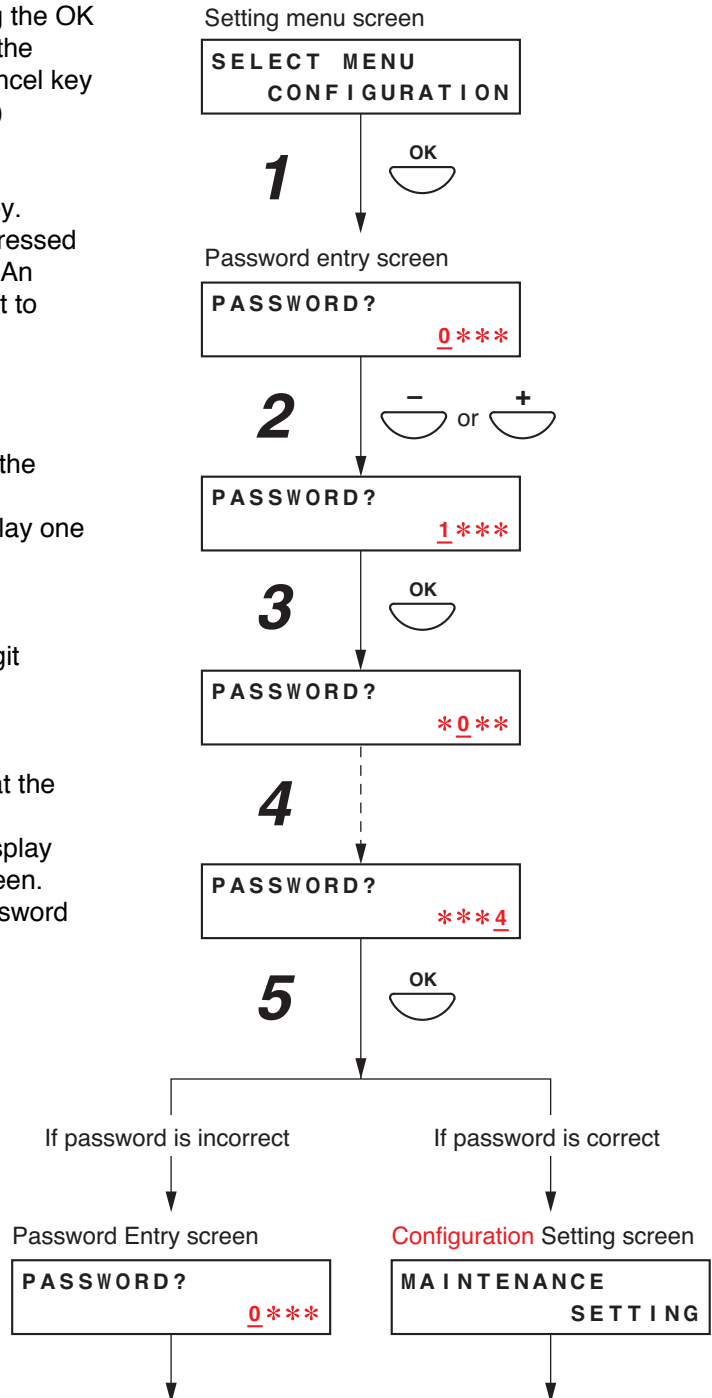

11.3.3. Configuration setting items

The screens shown here are only examples and may differ from the actual displays.
The sections in red are the setting items or contents that vary with the operation of the [+] or [-] key.

[Password settings]

Passwords can be set. (They need not be set if not necessary.)
Use only a 4-digit (numerical) number (0001 – 9999) when setting.
No password (display: "0000") is set by default.

Step 1. Press the OK key on the password setting screen.
The screen for setting the password will be displayed.
If a password has already been set, the set password is displayed.

Note
Pressing the Cancel key returns the display to the original screen.

Step 2. Enter a password using the [+] and [-] keys.
The underline () shown at the leftmost digit indicates the entry point.
The number increases with the [+] key and decreases with the [-] key.

Note
Enter "0000" when not using a password.

Step 3. Press the OK key.
The underline moves to the next (right side) digit.

Note
Pressing the Cancel key returns the display to the previous screen.

Step 4. Repeat Steps 2 and 3 to complete a 4-digit number.

Step 5. Press the OK key when the underline is at the fourth digit to register the password.

Step 6. Press the Cancel key after setting is complete.
The display reverts to the setting screen.

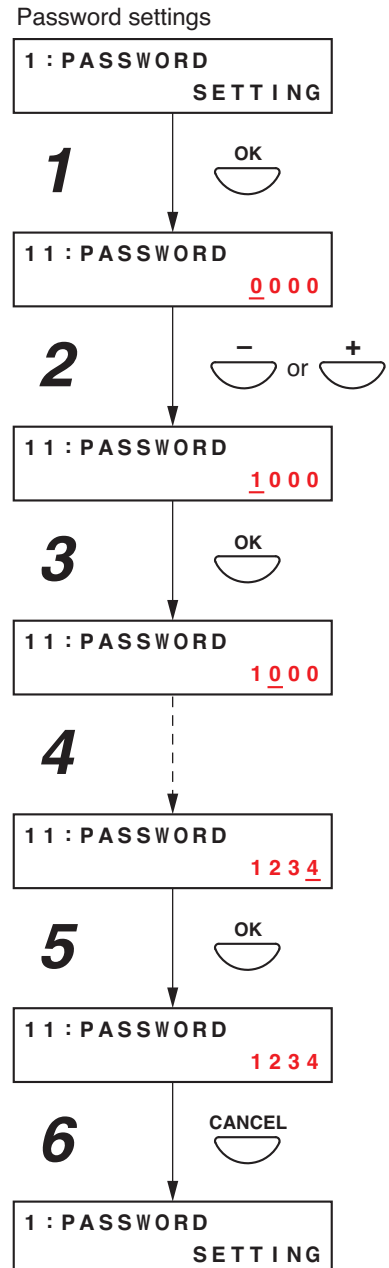

[Date/time settings]

Set the date and time.

Default setting: "2008 JAN 01, 00:00"

Step 1. Press the OK key on the Clock Setting screen.
The setting screen for date and time is displayed.

Note

Pressing the Cancel key returns the display to the original screen.

Step 2. Enter the "year" using the [+] and [-] keys.
The number increases with the [+] key and decreases with the [-] key.
The underline () shown at the "2008" digits indicates the entry point.

Step 3. Press the OK key.
The underline moves to the right.

Note

Pressing the Cancel key returns the display to the previous screen.

Step 4. Repeat Steps 2 and 3 to enter the date (day, month, and year) and time (hour and minute).

Step 5. Press the OK key when the underline is at the "minute" digits to register the date and time.
The time starts counting from 00 seconds when the OK key is pressed.

Step 6. Press the Cancel key after setting is complete.
The display reverts to the setting screen.

Date/time settings

2 : CLOCK SETTING

1



21 : 01 JAN 2008
00 : 00

2

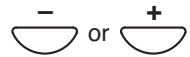

21 : 01 JAN 2009
00 : 00

3



21 : 01 JAN 2009
00 : 00

4

21 : 03 FEB 2009
04 : 05

5



21 : 03 FEB 2009
04 : 05

6



2 : CLOCK SETTING

[Network settings]

Set the IP address and subnet mask.

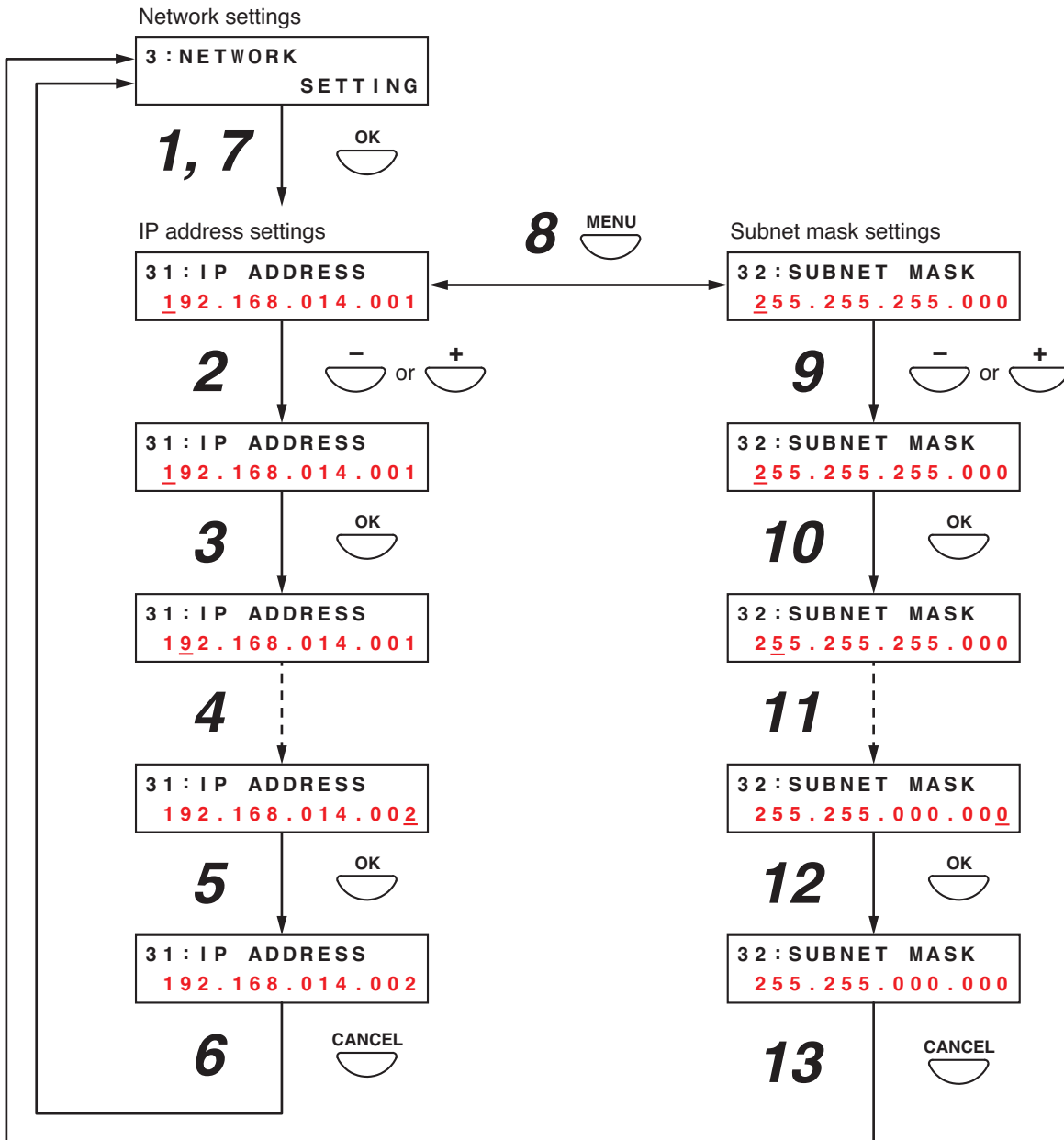

<IP address settings>

Step 1. Press the OK key on the Network Settings screen.
The IP Address settings screen is displayed.

Note

Pressing the Cancel key returns the display to the original screen.

Step 2. Enter an IP address using the [+] and [-] keys.
The number increases with the [+] key and decreases with the [-] key.
The underline (_) shown at the leftmost digit indicates the entry point.

Step 3. Press the OK key. The underline moves to the next (right side) digit.

Note

Pressing the Cancel key returns the display to the previous screen.

Step 4. Repeat Steps 2 and 3 to complete the IP address.

Step 5. Press the OK key when the underline is at the rightmost digit to register the IP address.

Step 6. Press the Cancel key after setting is complete.
The display reverts to the Network Settings screen.

<Subnet mask settings>

Step 7. Press the OK key on the Network Settings screen.
The IP Address settings screen is displayed.

Step 8. Press the Menu key.
The Subnet Mask Settings screen is displayed.

Step 9. Enter the subnet mask using the [+] and [-] keys.
The underline () shown at the leftmost digit indicates the entry point.

Step 10. Press the OK key. The underline moves to the next (right side) digit.

Note

Pressing the Cancel key returns the display to the previous screen.

Step 11. Repeat Steps 9 and 10 to complete the subnet mask.

Step 12. Press the OK key when the underline is at the rightmost digit to register the subnet mask.

Step 13. Press the Cancel key after setting is complete.
The display reverts to the Network Settings screen.

[Log transmission]

Transmit logs from the VM-3240VA to a PC.

Step 1. Press the OK key on the Log Transmission screen.
The indication "TRANSMITTING" is displayed on the screen.

Note
Pressing the Cancel key returns the display to the original screen.

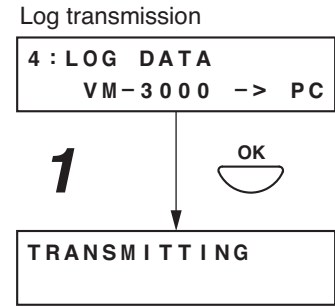

Step 2. Activate the setting software and click the [Log] menu item.
The following log display screen is displayed.

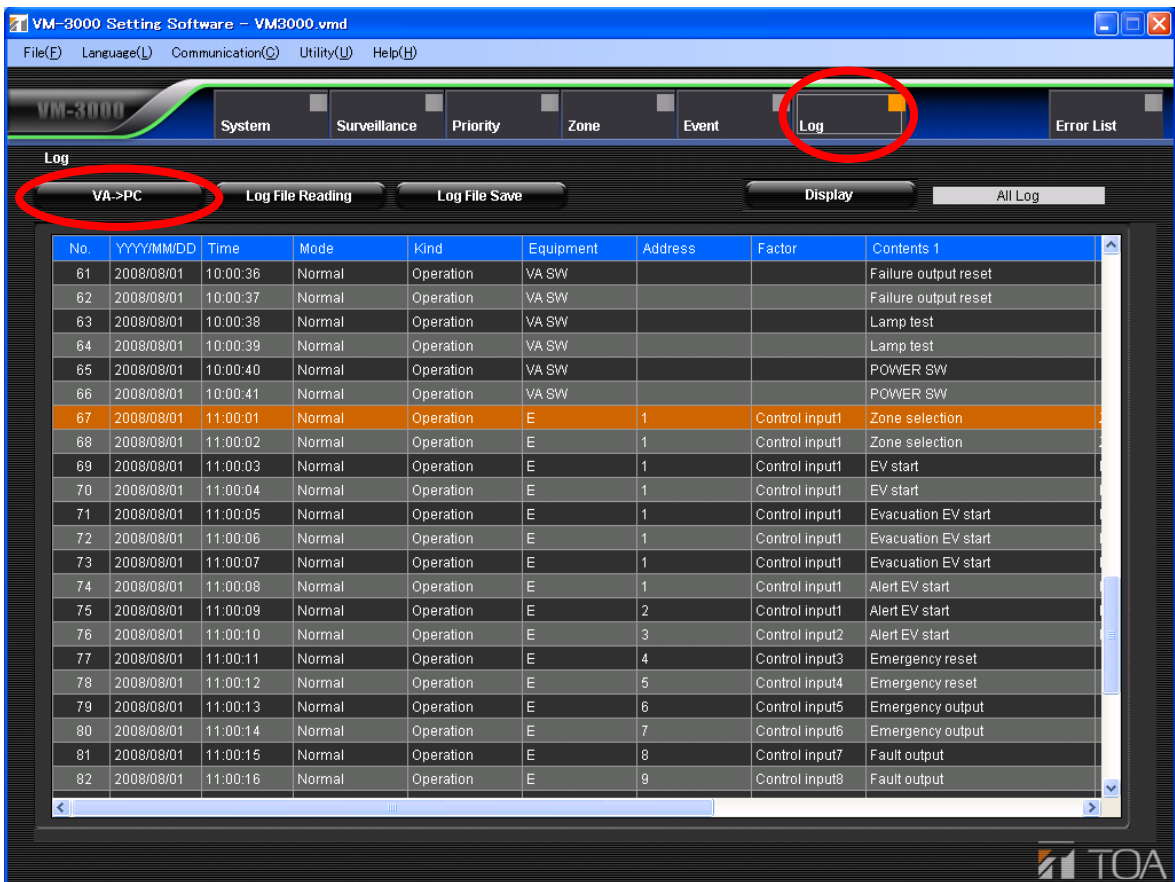

Pressing the [VA ⇒ PC] button starts the transmission of log data from the VM-3240VA to the PC.

The indication "TRANSMITTING COMPLETE" is displayed on the screen of the VM-3240VA after the transmission is completed.

Step 3. Press the OK key.
The display reverts to the setting screen.

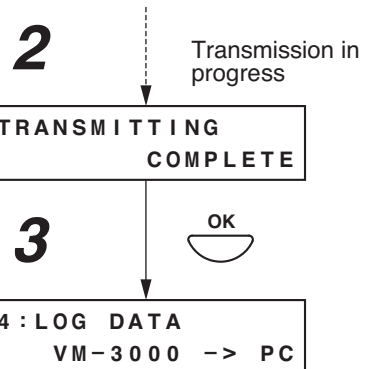

Note
If the PC is not correctly connected, the display will not change from the "TRANSMITTING" screen. In such cases, press the Cancel key to return to the log transmission screen, correctly reconnect the PC, and then press the OK key again.

[Transmission of PC-set data]

Transmit data set by a PC to the VM-3240VA from the PC or conversely from the VM-3240VA to the PC.

Step 1. Press the OK key on the Set Data Transmission screen.

The screen for selecting the transmission source and transmission destination is displayed.

Note

Pressing the Cancel key returns the display to the original screen.

Step 2. Press the Menu key to switch the source and destination.

Step 3. Press the OK key.
The "RECEIVING" or "TRANSMITTING" indication is displayed on the screen.

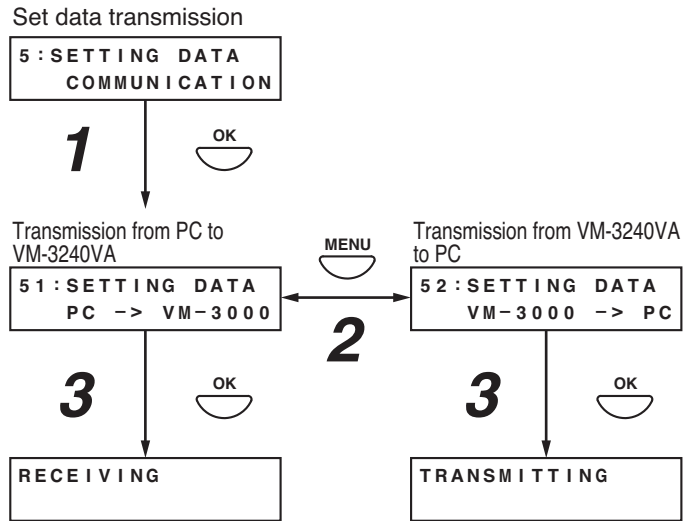

Step 4. Activate the setting software to transmit set data from the VM-3240VA to the PC or from the PC to the VM-3240VA. Click "Communication" on the menu bar and select "Setting Data: VA->PC" or "Setting Data: PC->VA" on the pull-down menu.

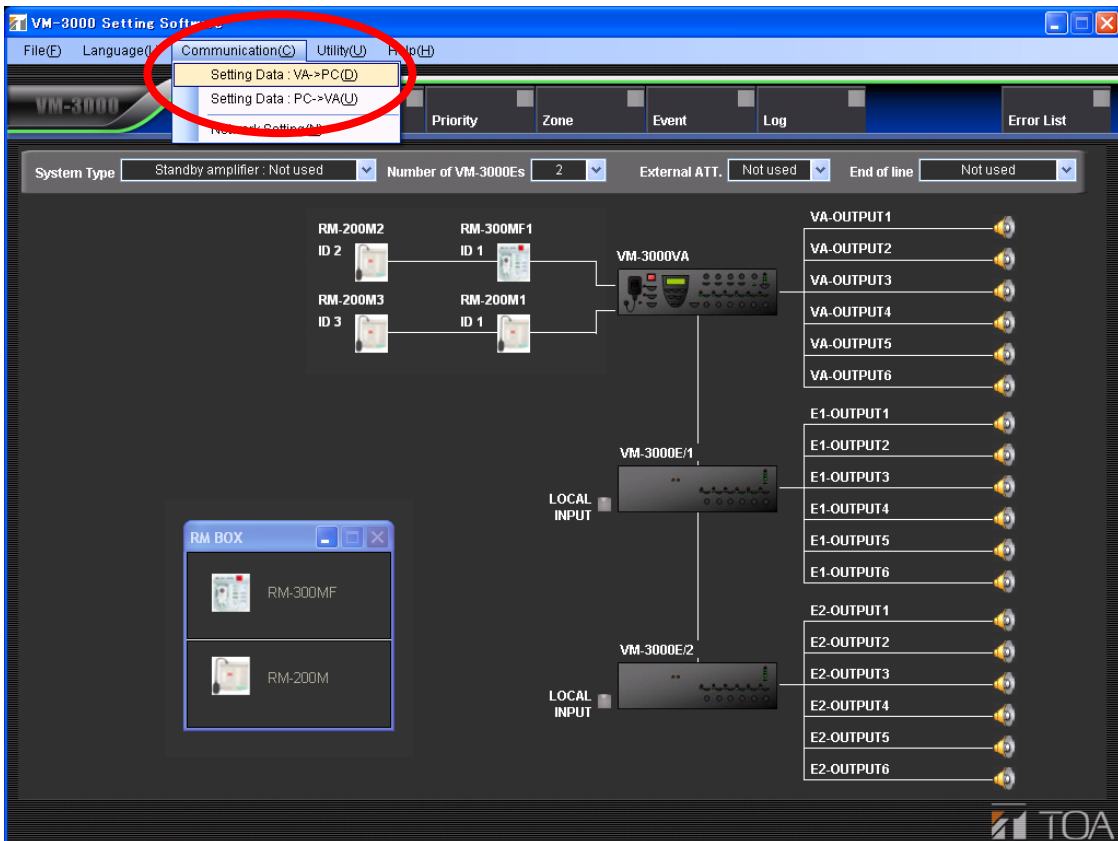

Selecting "Setting Data: VA->PC" allows PC-set data written to the VM-3240VA to be read into the software.

Selecting "Setting Data: PC->VA" transmits the data currently being set in the software to the VM-3240VA.

The indication "RECEIVING COMPLETE" or "TRANSMITTING COMPLETE" is displayed on the screen after the transmission is completed.

Step 5. Press the OK key.
The display reverts to the source and destination selection screen.

Step 6. Press the Cancel key.
The display reverts to the Set Data Transmission screen.

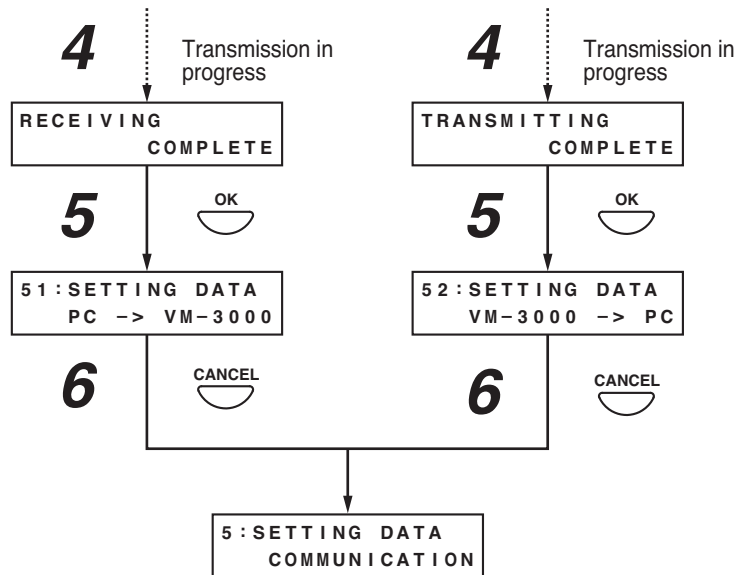

Note

If the PC is not correctly connected, the display will not change from the "RECEIVING" or "TRANSMITTING" screen.

In such cases, press the Cancel key to return to the set data transfer screen, correctly reconnect the PC, and then press the OK key again.

[Transmission of EV sound source data]

Transmit EV sound source data from a PC to the VM-3240VA or conversely from the VM-3240VA to the PC.

Step 1. Press the OK key on the EV sound source transmission screen.

The screen for selecting the transmission source and destination is displayed.

Note

Pressing the Cancel key returns the display to the original screen.

Step 2. Press the Menu key to switch the source and destination.

Step 3. Press the OK key.

The "RECEIVING" or "TRANSMITTING" indication is displayed on the screen and the transmission begins.

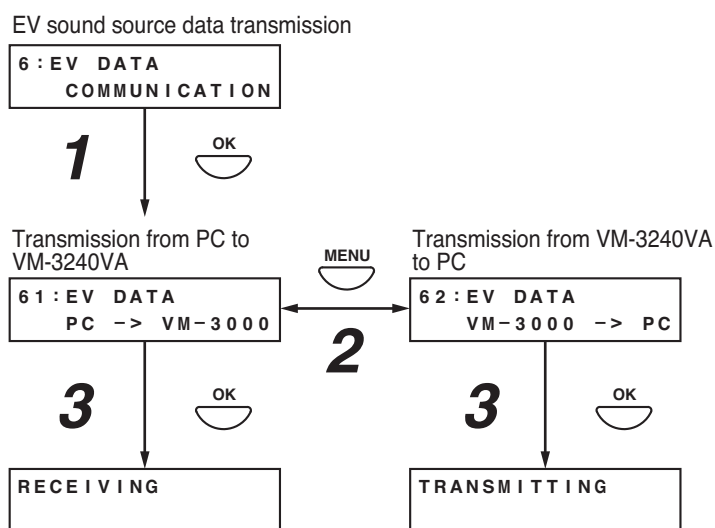

Step 4. Activate the setting software to transmit the EV sound source data from the VM-3240VA to the PC or from the PC to the VM-3240VA, then click "Utility->EV" on the menu bar.

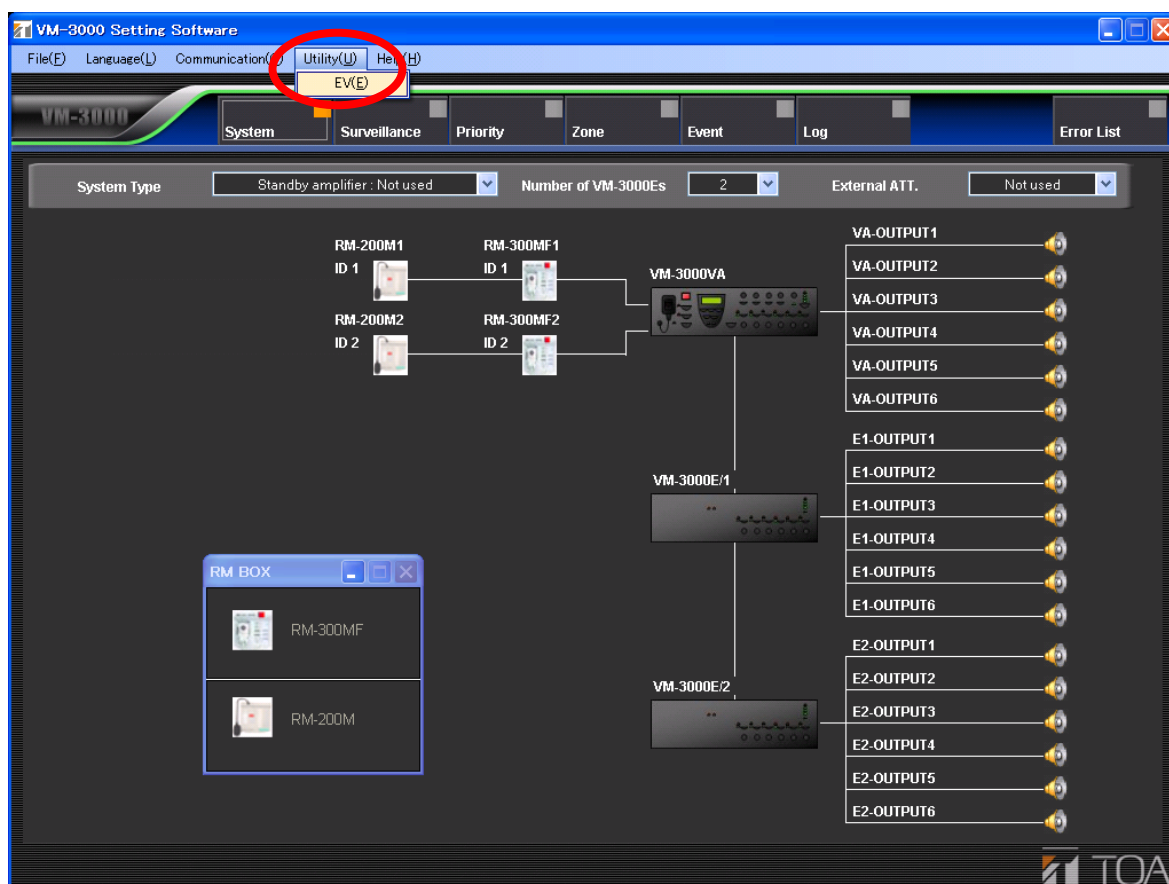

The EV message sound source file registration screen is displayed.

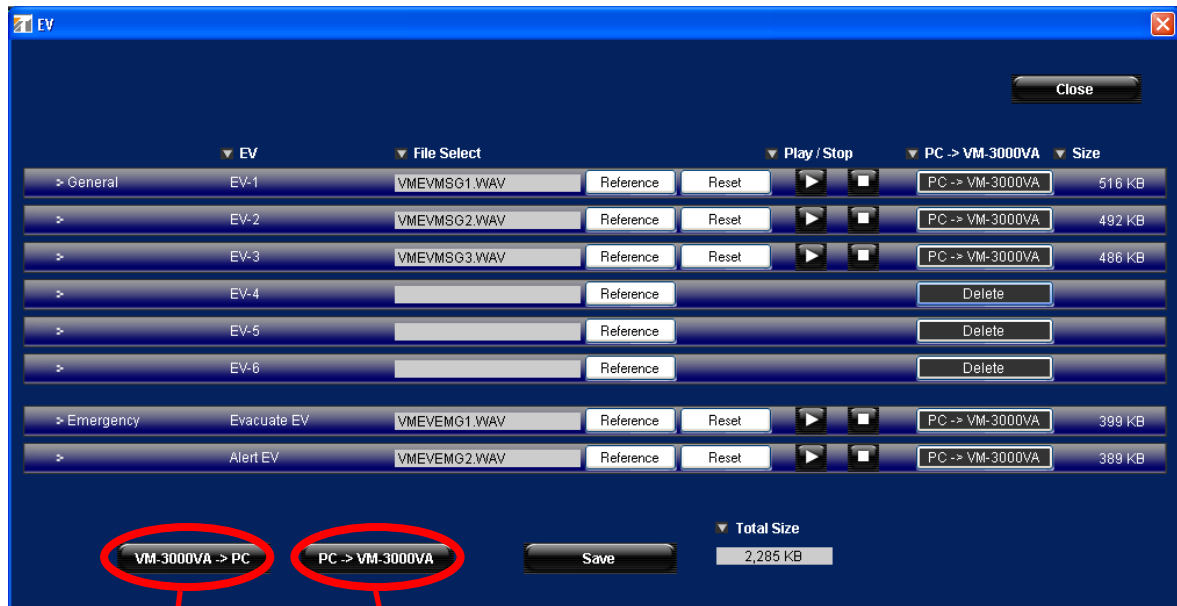

Press the [PC->VM-3000VA] button to transmit sound source data from the PC to the VM-3240VA after reading the sound source data into the above screen.

Press the [VM-3000VA->PC] button to transmit sound source data from the VM-3240VA to the PC. Sound source data written into the VM-3240VA is read into the current registration screen.

Step 5. Press the OK key.
The display reverts to the transmission source and transmission destination selection screen.

Step 6. Press the Cancel key.
The display reverts to the Set Data Transmission screen.

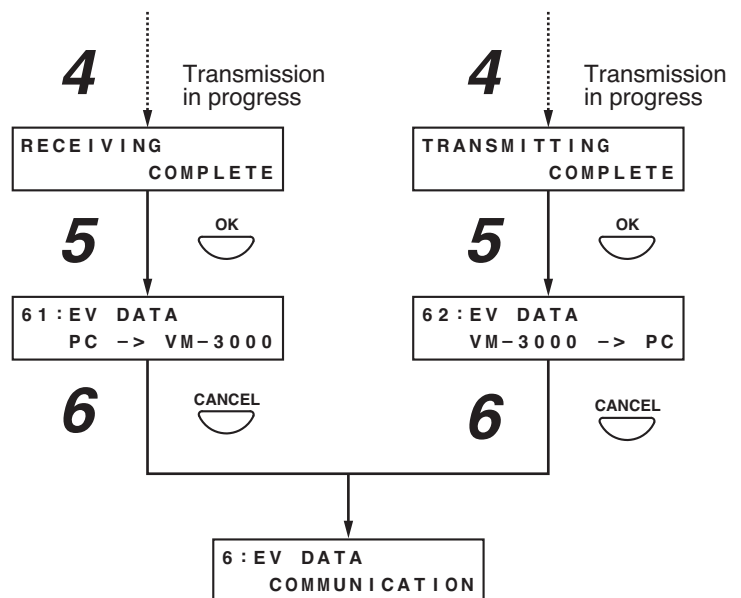

Note

If the PC is not correctly connected, the display will not change from the "RECEIVING" or "TRANSMITTING" screen. In such cases, press the Cancel key to return to the EV sound source data transfer screen, correctly reconnect the PC, and then press the OK key again.

11.4. Information Settings

11.4.1. Information setting hierarchical chart

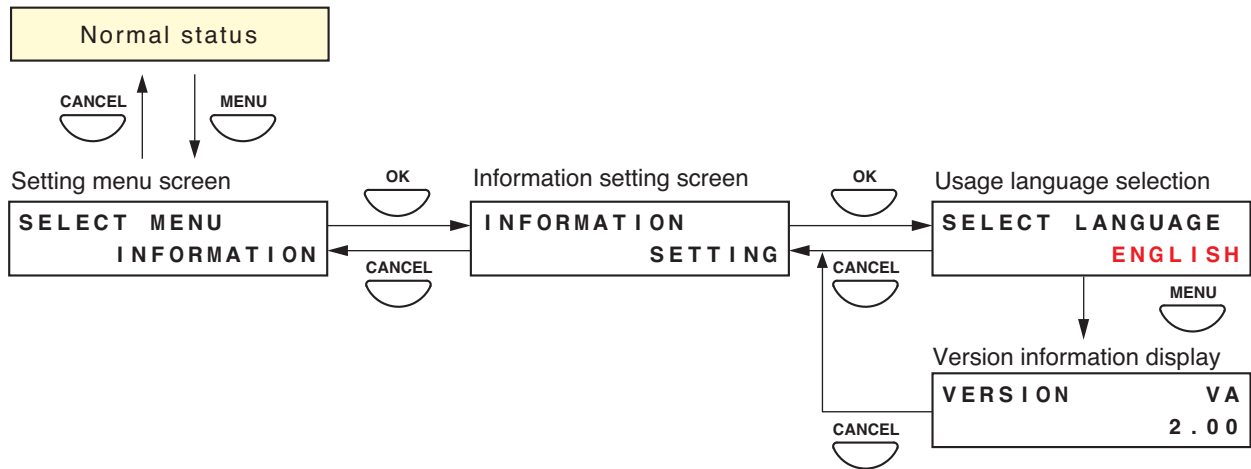

11.4.2. Information setting items

The screens shown here are only examples and may differ from the actual displays. The sections in red are the setting items or contents that vary with the operation of the [+] or [-] key.

[Usage language selection]

Select the language to be displayed on the VM-3240VA's LCD screen.

Setting range	ENGLISH (default) and DEUTSCH (German)
---------------	--

Step 1. Using the [+] and [-] keys, select the language to be used on the language selection screen.

Step 2. Press the OK key to register the language.

Note

Pressing the Cancel key before registering the language by pressing the OK key cancels the set contents and returns the display to the Information Setting screen.

Step 3. Press the Cancel key to return to the Information Setting screen.

The screen is displayed in the selected language.

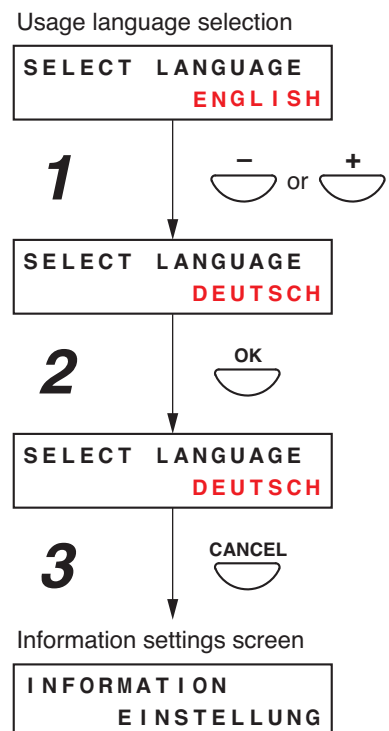

[Version information display]

Version information is displayed on the VM-3240VA's front panel-mounted LCD screen.

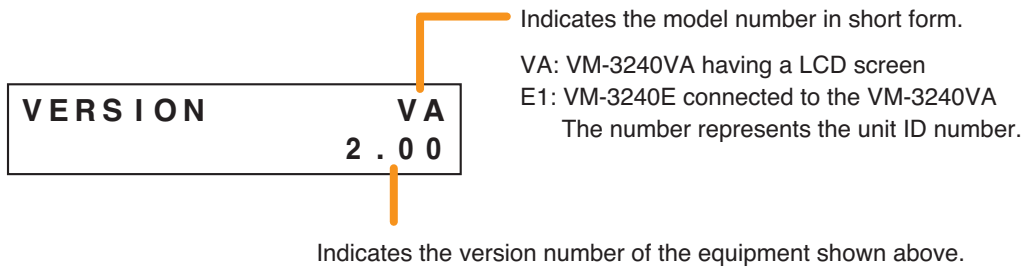

Step 1. Using the [+] or [-] key, select the desired equipment on the Version display screen.
The version number of the corresponding equipment is displayed.

Step 2. Press the Cancel key to return to the Information Setting screen.

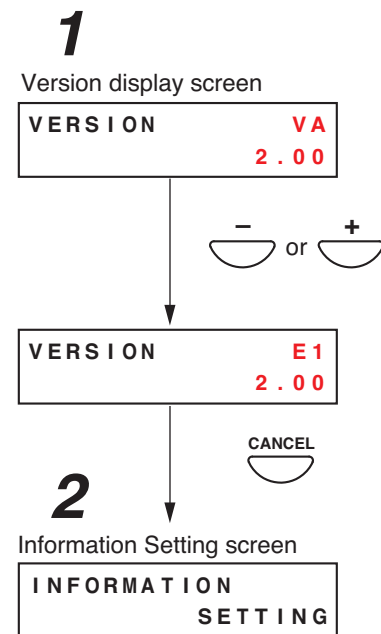

11.5. Audio Settings

This function is used to adjust the audio setting parameters.

Tone settings can be adjusted for Input 4 and volume adjusted for BGM 1 and 2 as well as for the chime interlocked with the microphone, Alert/Evacuation message announcements, and automatic general announcements.

Perform each setting after the system installation and connections have been completed.

11.5.1. Audio settings hierarchical chart

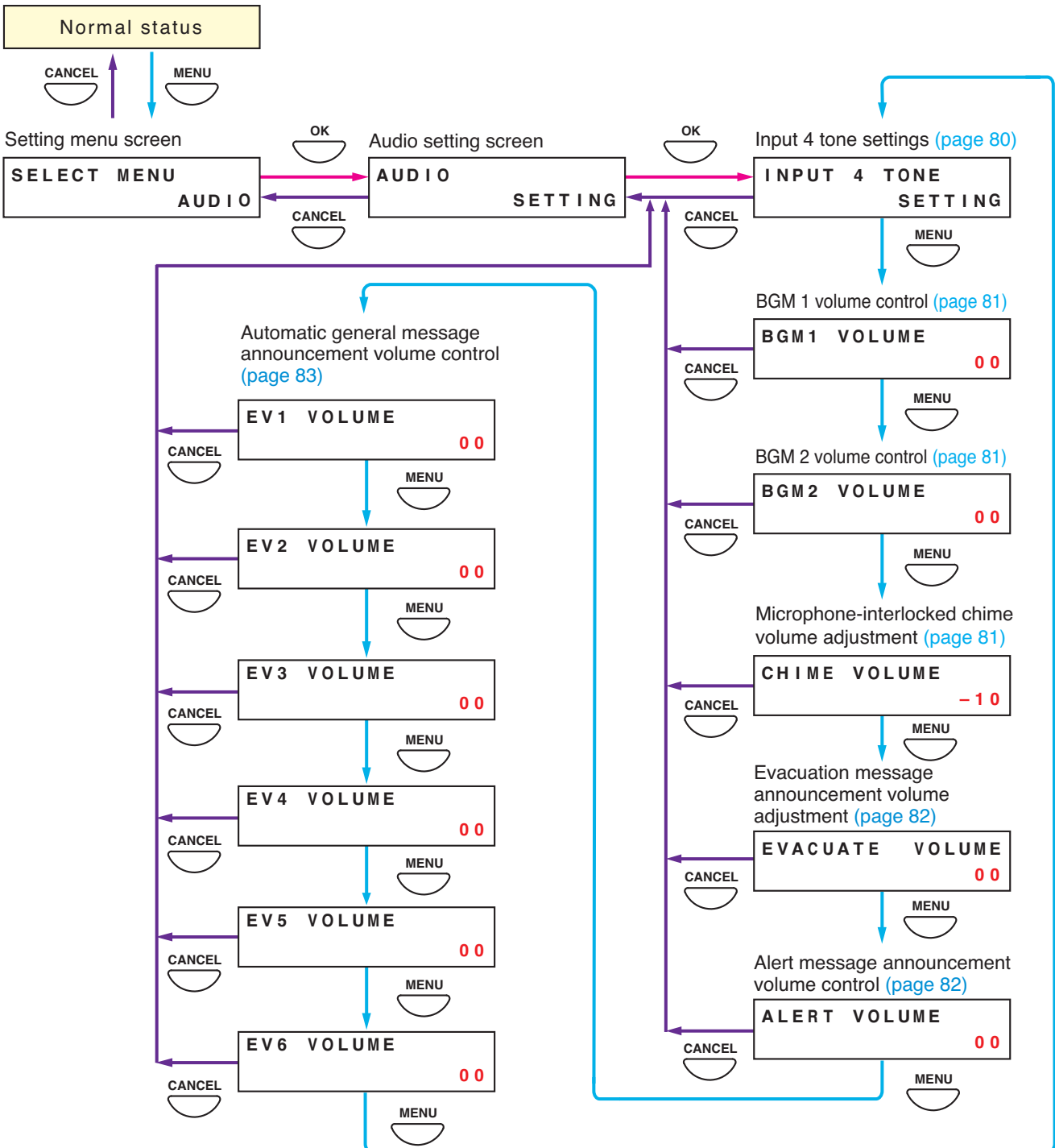

11.5.2. Audio setting items

The screens shown here are only examples and may differ from the actual displays. The sections in red are the setting items or contents that vary with the operation of the [+] or [-] key.

[Input 4 tone settings]

Set the tone (bass and treble) for Input 4.

Setting range	+10 dB to -10 dB (default: 00)
---------------	--------------------------------

Note

To set Inputs 1 – 3, use the Input Selector key (Input 1 – 3) on the front panel of the VM-3240VA. (Refer to [page 85](#).)

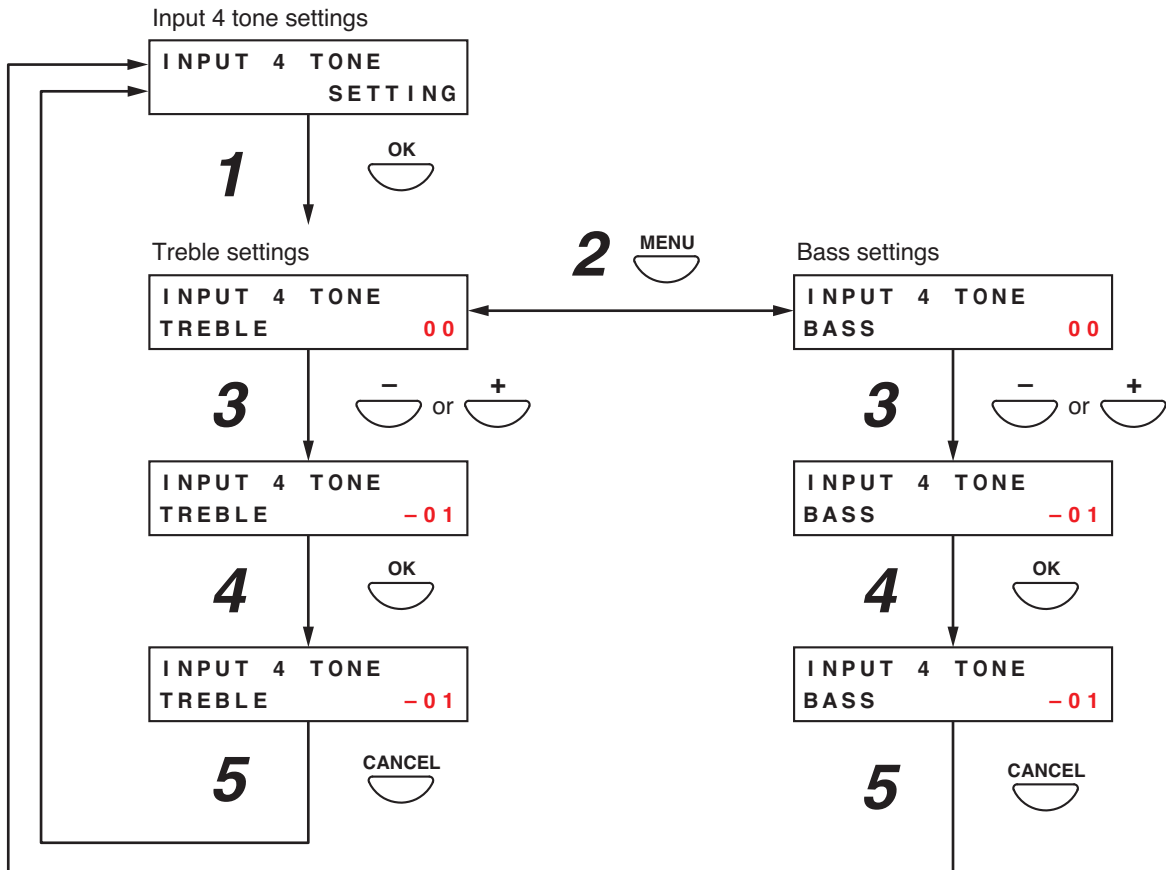

Step 1. Press the OK key on the Input 4 Tone Settings screen. The Treble Settings screen is displayed.

Note

Pressing the Cancel key returns the display to the original screen.

Step 2. Press the Menu key to switch between the Treble and Bass settings screens.

Step 3. Set the treble or bass level using the [+] or [-] key. The level increases with the [+] key and decreases with the [-] key.

Step 4. Press the OK key to register the set level.

Note

Pressing the Cancel key before registering the level by pressing the OK key cancels the set contents and returns the display to the Input 4 Tone Settings screen.

Step 5. Press the Cancel key to return to the Input 4 Tone Settings screen.

[BGM 1 and BGM 2 volume adjustment]

Adjust the volume of BGM1 and BGM2.

Setting range	+10 dB to -10 dB (default: 00)
---------------	--------------------------------

Step 1. Using the [+] and [-] keys, adjust the volume on the BGM 1 or BGM 2 Volume Settings screen. The volume increases with the [+] key and decreases with the [-] key.

Step 2. Press the OK key to register the set volume level.

Note

Pressing the Cancel key before registering the level by pressing the OK key cancels the set contents and returns the display to the Audio Settings screen.

(Example. When adjusting BGM 1 volume:)

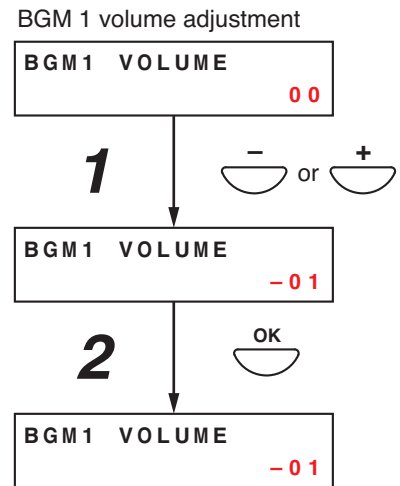

[Microphone-interlocked chime volume adjustment]

Adjust the volume of the chime that is interlocked with the microphone.

Setting range	+10 dB to -10 dB (default: 00)
---------------	--------------------------------

Step 1. Using the [+] and [-] key, adjust the volume on the Microphone-Interlocked Chime Volume Adjustment screen.

Step 2. Press the OK key to register the set volume level.

Note

Pressing the Cancel key before registering the level by pressing the OK key cancels the set contents and returns the display to the Audio Settings screen.

Microphone-interlocked chime volume control

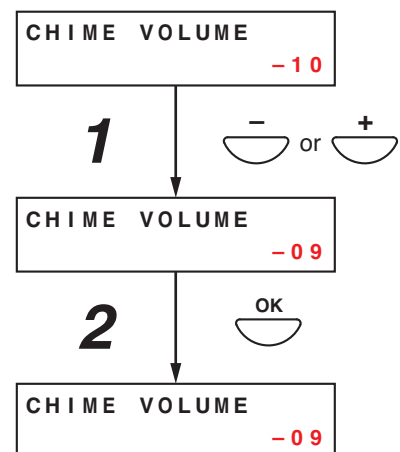

[Evacuation message announcement volume adjustment]

Adjust the volume of Evacuation message announcement internally pre-recorded on the VM-3240VA.

Setting range	+10 dB to -10 dB (default: 00)
---------------	--------------------------------

Step 1. Using the [+] or [-] key, adjust the volume on the Evacuation Message Announcement Volume Adjustment screen.

Step 2. Press the OK key to register the set volume level.

Note

Pressing the Cancel key before registering the level by pressing the OK key cancels the set contents and returns the display to the Audio Setting screen.

Evacuation message announcement volume adjustment

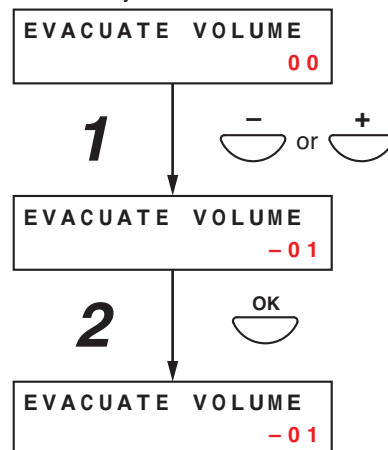

[Alert message announcement volume adjustment]

Adjust the volume of Alert message announcement internally pre-recorded on the VM-3240VA.

Setting range	+10 dB to -10 dB (default: 00)
---------------	--------------------------------

Step 1. Using the [+] or [-] key, adjust the volume on the Alert Message Announcement Volume Adjustment screen.

Step 2. Press the OK key to register the set volume level.

Note

Pressing the Cancel key before registering the level by pressing the OK key cancels the set contents and returns the display to the Audio Setting screen.

Alert message announcement volume adjustment

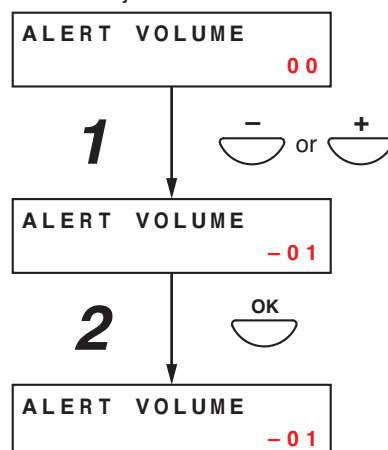

[Automatic general message announcement volume control]

Adjust the volume of Automatic general message announcements (EV1 – 6).

Setting range	+10 dB to –10 dB (Default: 00)
---------------	--------------------------------

EV1 - 6 represent the Automatic general message announcement numbers. For details, refer to the separate software instruction manual.

Step 1. Using the [+] or [-] key, adjust the volume on the Volume Adjustment screen for the EV1 – 6.

Step 2. Press the OK key to register the set volume level.

Note

Pressing the Cancel key before registering the level by pressing the OK key cancels the set contents and returns the display to the Audio Setting screen.

Automatic general message announcement volume level control

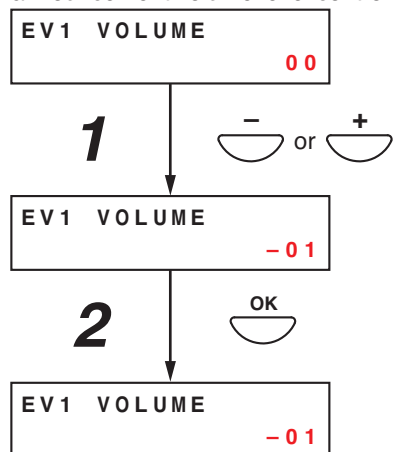

11.6. Surveillance Settings

Notes

- When using the Surveillance function (refer to ["What Is the Surveillance Function?" on page 49](#)), be sure to perform this setting after system installation and connections have been completed. Also, be sure to perform this setting when the number of connected speakers has been changed. If this setting is not performed, the surveillance function will not operate correctly.
- When initializing the surveillance settings, be sure to set all the attenuators connected for maximum output. Doing otherwise may cause false detection.

11.6.1. Surveillance setting hierarchical chart

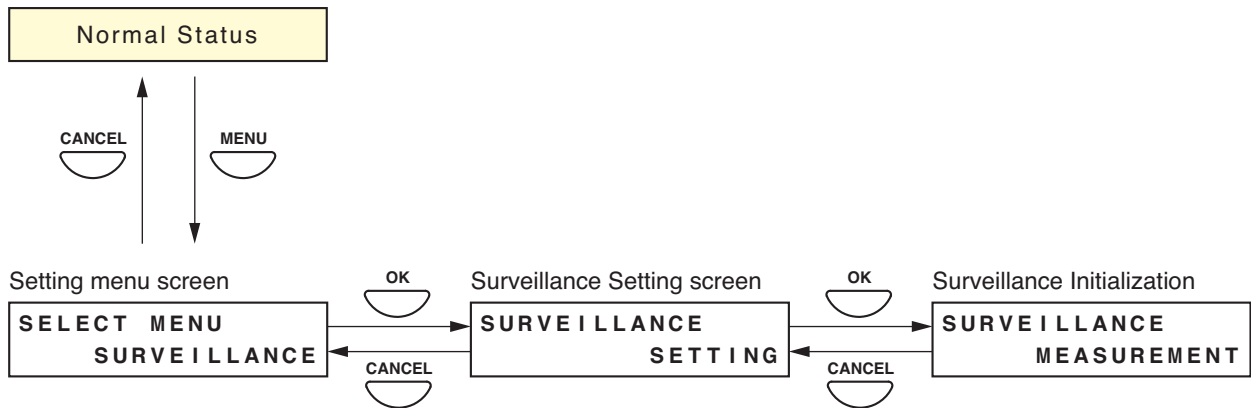

11.6.2. Surveillance setting items

[Surveillance initialization]

Initialize the surveillance function.

Note

Do not start initializing the surveillance function for 1 minute after system reset.

- Step 1.** Press the OK key on the surveillance initialization screen. The "MEASURING" indication is displayed on the screen and initialization begins. After initialization is complete, the "MEASURING COMPLETE" indication is displayed on the screen.
- Step 2.** Press the OK key to return to the Surveillance Initialization screen.

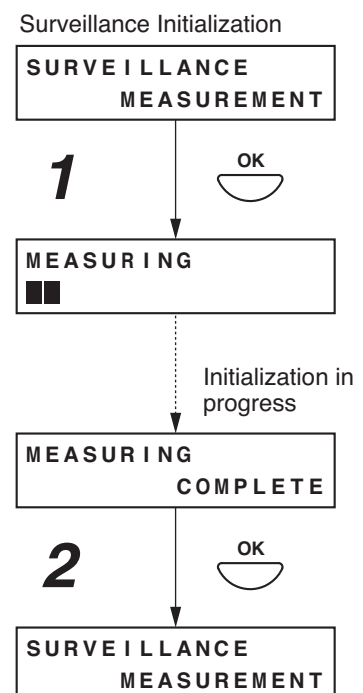

11.7. Inputs 1 – 3 Settings

LINE/MIC input can be selected, phantom power turned ON/OFF, and treble and bass set for Inputs 1 – 3 during actual sound output.

Perform this setting after system installation and connections have been completed.

The screens shown here are only examples and may differ from the actual displays.

The sections in red are the setting items or contents that vary with the operation of the [+] or [-] key.

11.7.1. Inputs 1 – 3 setting hierarchical chart

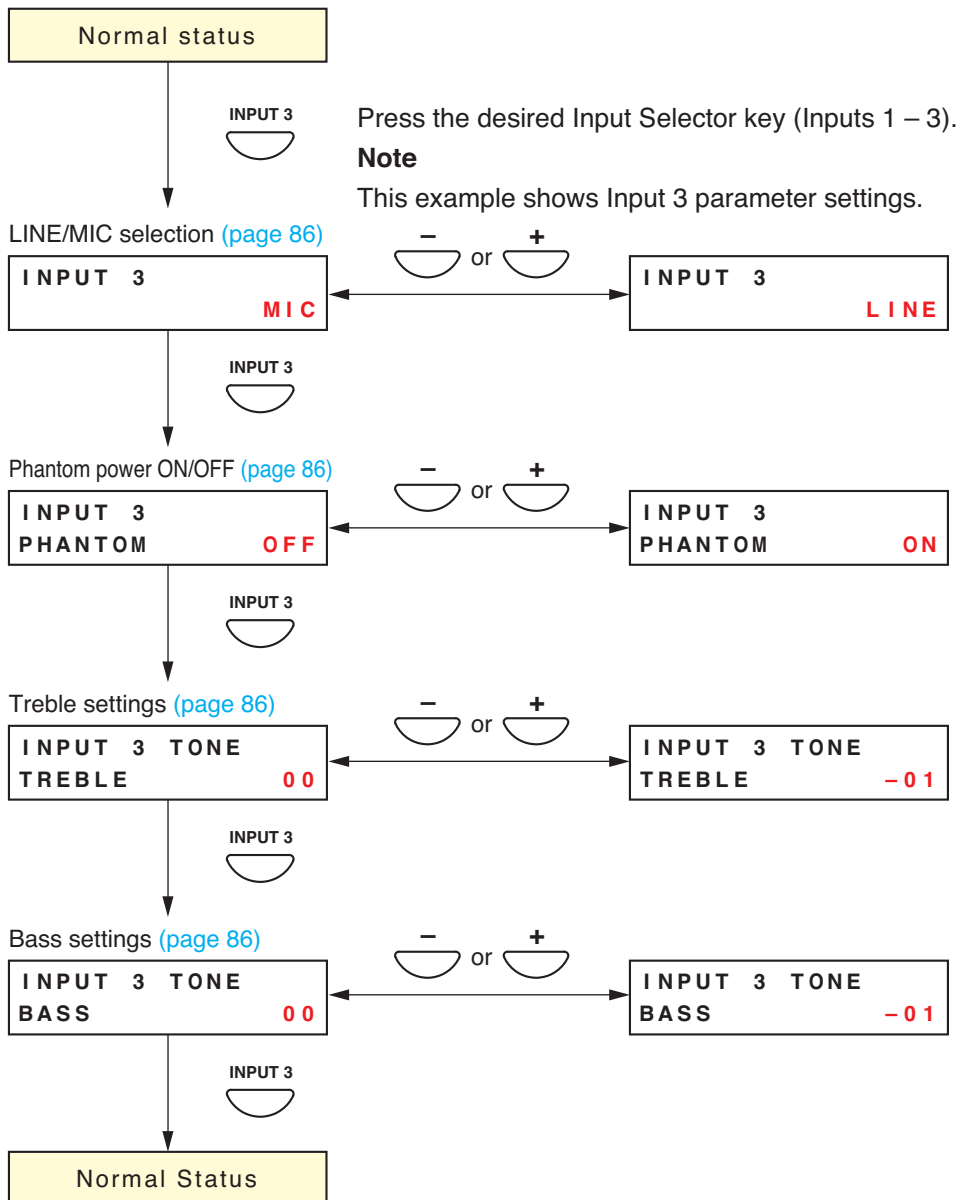

11.7.2. Inputs 1 – 3 setting items

[LINE/MIC selection settings]

Select either LINE or MIC input.

Setting range	Line and Mic (Default: LINE)
---------------	------------------------------

[Phantom ON/OFF settings]

This setting item will not appear when "LINE" is selected at the LINE/MIC selection setting item.
Set whether to enable or disable the phantom power.

Setting range	ON and OFF (Default: OFF)
---------------	---------------------------

[Treble settings]

Perform treble settings.

Setting range	+10 dB to -10 dB (Default: 00)
---------------	--------------------------------

[Bass settings]

Perform bass settings.

Setting range	+10 dB to -10 dB (Default: 00)
---------------	--------------------------------

11.8. BGM Settings

Bass and treble of BGM can all be set during actual sound output.
Perform this setting after system installation and connections have been completed.

The screens shown on the previous page are only examples and may differ from the actual displays.
The sections in red are the setting items or contents that vary with the operation of the [+] or [-] keys.

11.8.1. BGM setting hierarchical chart

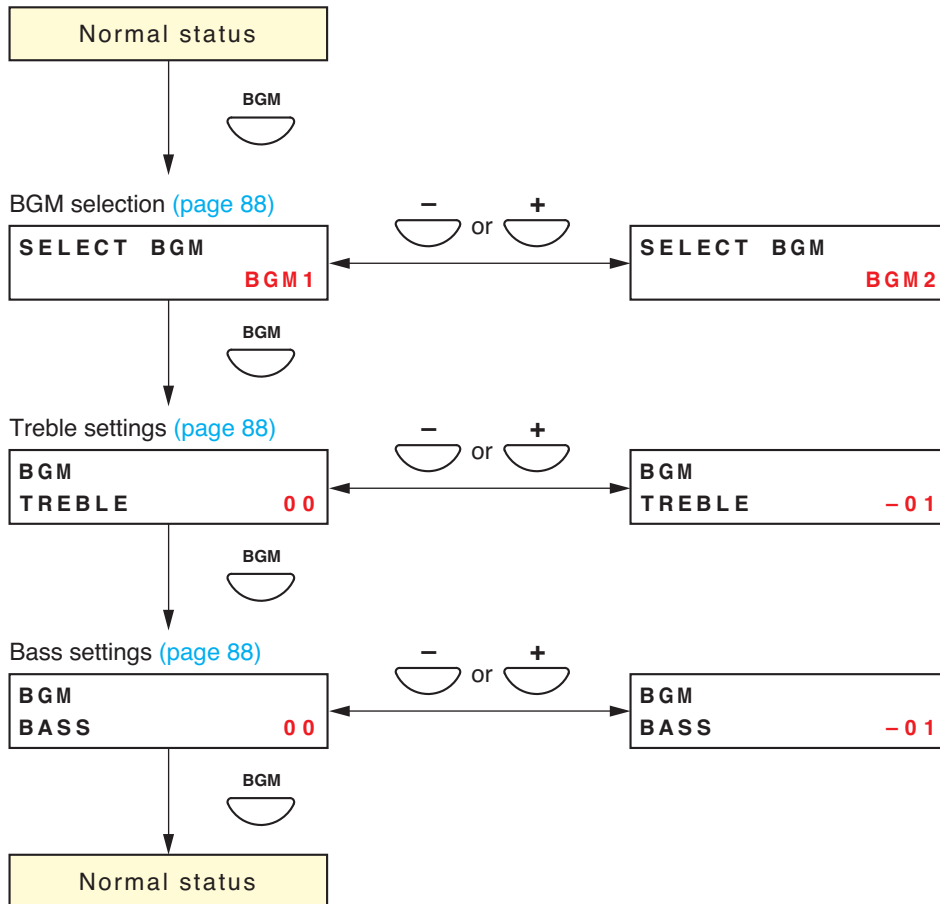

11.8.2. BGM setting items

[BGM selection]

Select BGM 1 or 2. Press the OK key to confirm the selected BGM output and commence BGM broadcasting. (For details, refer to "BGM Broadcasts" in "Making General Broadcasts" on page 25.)

Setting range	BGM 1, BGM 2 and OFF (default)
---------------	--------------------------------

[Treble settings]

Perform treble settings.

Setting range	+10 dB to -10 dB (Default: 00)
---------------	--------------------------------

[Bass settings]

Perform bass settings.

Setting range	+10 dB to -10 dB (Default: 00)
---------------	--------------------------------

12. REMOTE MICROPHONE SETTINGS (RM-300MF, RM-200M)

12.1. DIP Switch Functions

12.1.1. RM-300MF

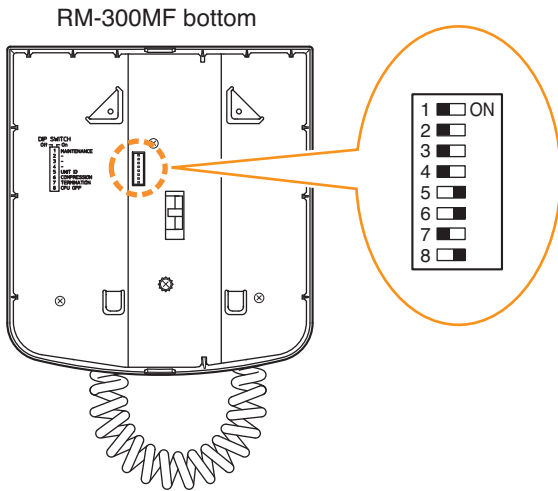

Switch No.	Function	Factory-preset
1	Maintenance mode	OFF
2		
3	—	
4		
5	Unit ID No. setting	ON
6	Compression ON/OFF	
7	RM terminate ON/OFF	OFF
8	CPU OFF function	ON

Note

Always set the DIP switch 1 to the OFF position.
The unit will not operate if it is set to the ON position.

12.1.2. RM-200M

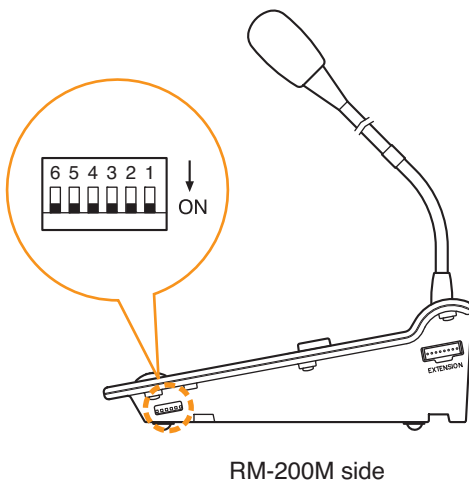

Switch No.	Function	Factory-preset
1	Unit ID No. setting	ON
2		
3	—	
4	Talk key operation	
5	—	
6	Compression ON/OFF	

12.2. Unit ID Number Settings

(RM-300MF: Switch 5 operation or RM-200M: Switch 1 and 2 operation)

To set the unit ID number, use the DIP switch 5 for the RM-300MF and DIP switches 1 and 2 for the RM-200M.

Note

The DIP switch is located on the bottom surface for the RM-300MF and on the side surface for the RM-200M.

Set the unit ID numbers of the RM-300MF and RM-200M.

Make the Setting Software-assigned ID numbers for these units and the ID numbers set by their DIP switches identical. (All DIP switches set to ON by default)

(For setting instructions using the Setting Software, refer to the separate Setting Software Instructions, "RM function key settings.")

[RM-300MF]

Unit ID No.	Switch No. 5
1	ON
2	OFF

[RM-200M]

Unit ID No.	Switch No. 1	Switch No. 2
1	ON	ON
2	OFF	ON
3	ON	OFF
4	OFF	OFF

Note

Be sure to press the VM reset switch located on the VM-3240VA's front panel to cycle the system power when the unit ID has been changed with the system power switch turned on.

12.3. Compression Settings

(RM-300MF: Switch 6 operation or RM-200M: Switch 6 operation)

To perform compression settings, use the DIP switch No. 6 for both the RM-300MF and RM-200M.

Note

DIP switch is located on the bottom surface for the RM-300MF and on the side surface for the RM-200M.

Setting the DIP switch to ON enables announcements to be broadcast without distortion even if excessive input signal is applied to the microphone. (Default: ON)

12.4. Setting the Terminating RM-300MF Unit (RM-300MF: Switch 7 operation)

Set the DIP switch 7 located on the RM-300MF's bottom surface to ON when connecting a single RM-300MF to the VM-3240VA (no bridge connection to the RM-200M is made). (Default: OFF)

12.5. CPU OFF Function Enable/Disable Settings (RM-300MF: Switch 8 operation)

Enables or disables CPU OFF function by the RM-300MF's front-mounted CPU ON/OFF switch. Setting the DIP switch 8 located on the RM-300MF's side surface to ON enables CPU OFF function, and setting it to OFF disables CPU OFF function. (Default: ON)

Note

For the CPU ON/OFF switch settings, refer to ["Making All-Zone Calls Using the CPU OFF Function" on page 47](#).

12.6. Talk Key Settings (RM-200M: Switch 4 operation)

Set the operating system of the RM-200M's front-mounted Talk key. Setting the DIP switch 4 located on the RM-200M's side surface to ON enables announcement to be broadcast while the Talk key is held down. Releasing the Talk key terminates the broadcast. (Press-To-Talk or PTT mode)
Setting the DIP switch 4 to OFF enables a broadcast to initiate and pressing the key again terminates the broadcast. (Lock mode)
(Default: ON)

12.7. Maintenance Mode (RM-300MF: Switch 1 operation)

Not used.

Always set the DIP switch 1 located on the RM-300MF's bottom surface to the OFF position. (Default: OFF)

Note

If this switch is set to ON, the unit is placed in the maintenance mode and the RM-300MF's front-mounted Communication Failure indicator lights green, causing the unit not to work.

13. INSTALLATION

13.1. Installing the RM-300MF on a Wall

To mount the RM-300MF on the wall, the following parts are required.

Wall mount bracket unit for the RM-300MF	1	(supplied with the RM-300MF)
Tapping screw 4 x 25 (for wooden wall mounting)	2	(supplied with the RM-300MF)

[Installation]

Step 1. Install the wall mount bracket unit supplied with the RM-300MF on the wall.

Install the unit on the wall using 2 screws.

The RM-300MF comes with 2 tapping screws (4 x 25) for direct wall mounting.

However, if these supplied screws are not appropriate for the mounting, prepare appropriate ones separately.

⚠ WARNING

- Install the unit only in a location that can structurally support the weight of the unit and the mounting bracket. Doing otherwise may result in the unit falling down and causing personal injury and/or property damage.
- Be sure to install the bracket on the wall using 2 screws.

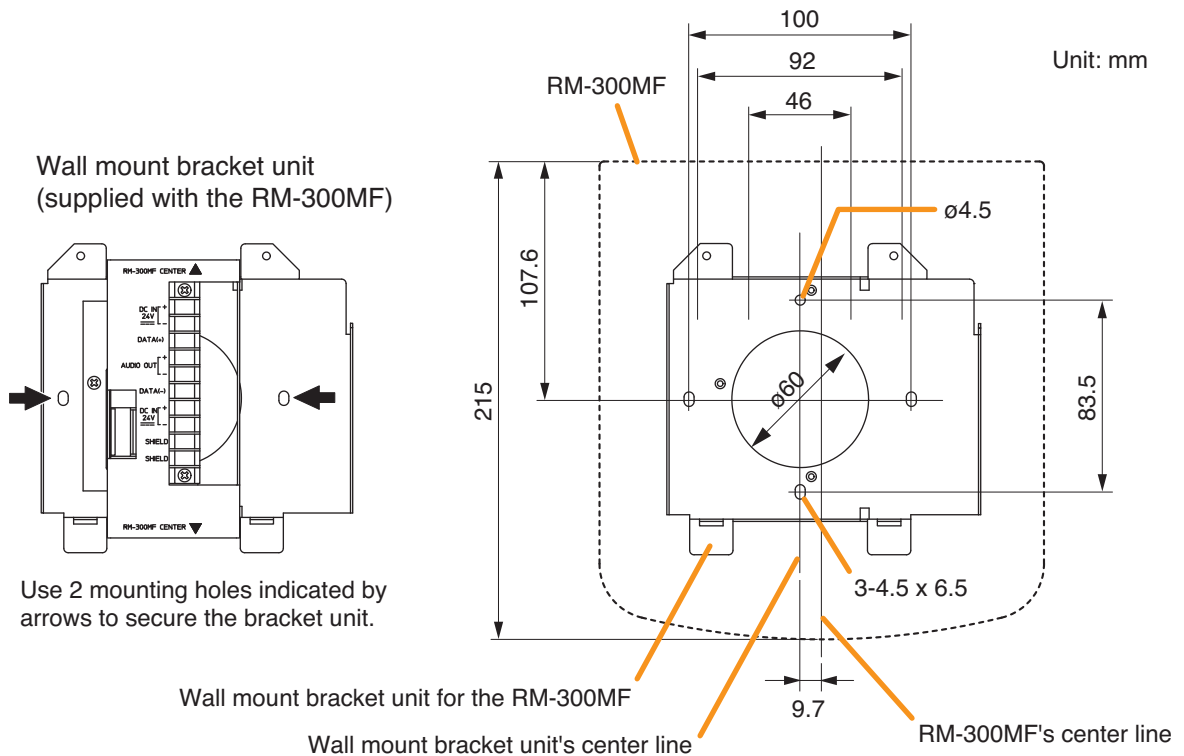

Step 2. Connect the link cable to the screw terminal block.
 For cable connection, refer to "RM-300MF connection" on [page 112](#).

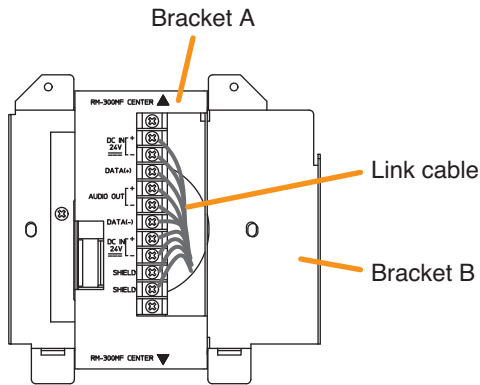

Note
 Put the link cable inside the Bracket A after connection completion.
 Do not allow the link cable to protrude.
 The cable may be damaged if it protrudes when the bracket unit is installed onto the wall.

Wall mount bracket unit
 (supplied with the RM-300MF)

Step 3. Plug the RM-300MF's connection cable into the connector port on the wall mount bracket unit.

Step 4. Attach the RM-300MF unit to the wall mount bracket unit.

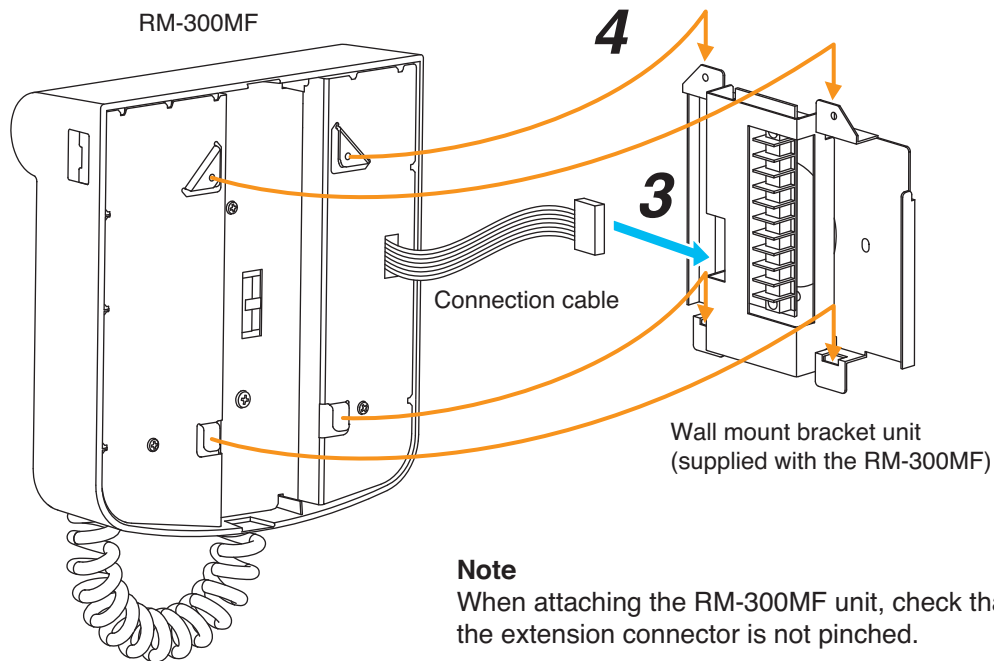

Note
 When attaching the RM-300MF unit, check that the extension connector is not pinched.

[When the RM-300MF is installed in a wall box]

When the RM-300MF is installed in a wall box (prepare separately), the box should measure at least 300 mm wide x 315 mm high as illustrated below.

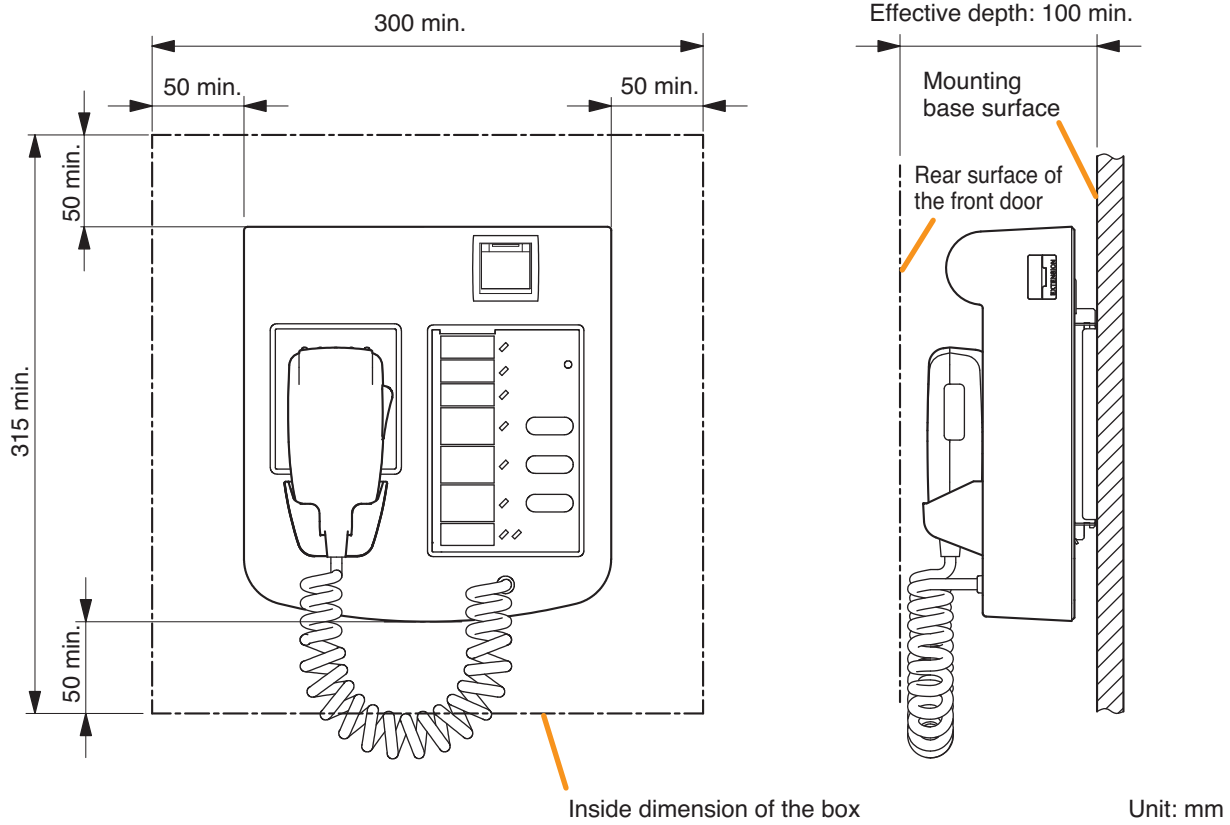

13.2. Installing the RM-320F on a Wall

To mount the RM-320F on the wall, the following parts are required.

Wall mount bracket for the RM-320F	1 (supplied with the RM-320F)
Tapping screw 4 x 25 (for direct wall mounting)	2 (supplied with the RM-320F)

Step 1. Install the wall mount bracket unit supplied with the RM-300MF on the wall. (Refer to [pages 92 and 93, Steps 1 and 2.](#))

Step 2. Place the RM-320F's bracket so that it fits in the RM-300MF's bracket as shown below. Then, fix the RM-320F's bracket to the wall with the supplied 2 tapping screws.

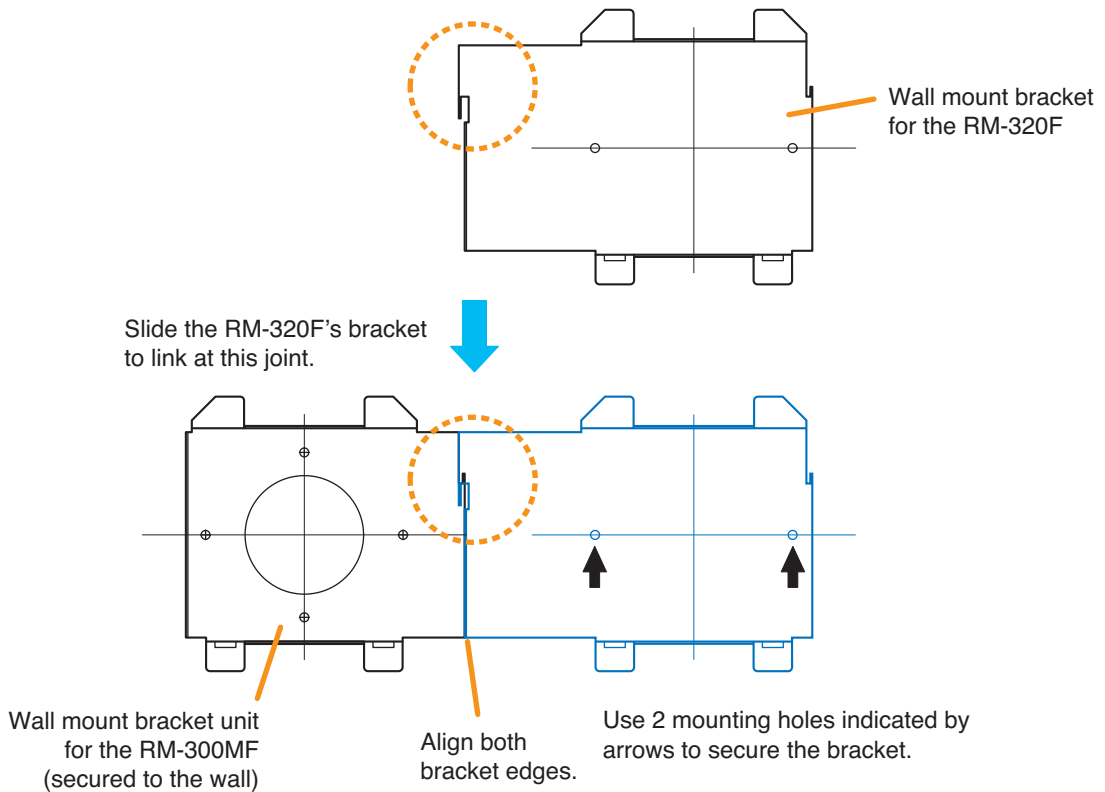

[Positional dimensions of the RM-300MF and RM-320F]

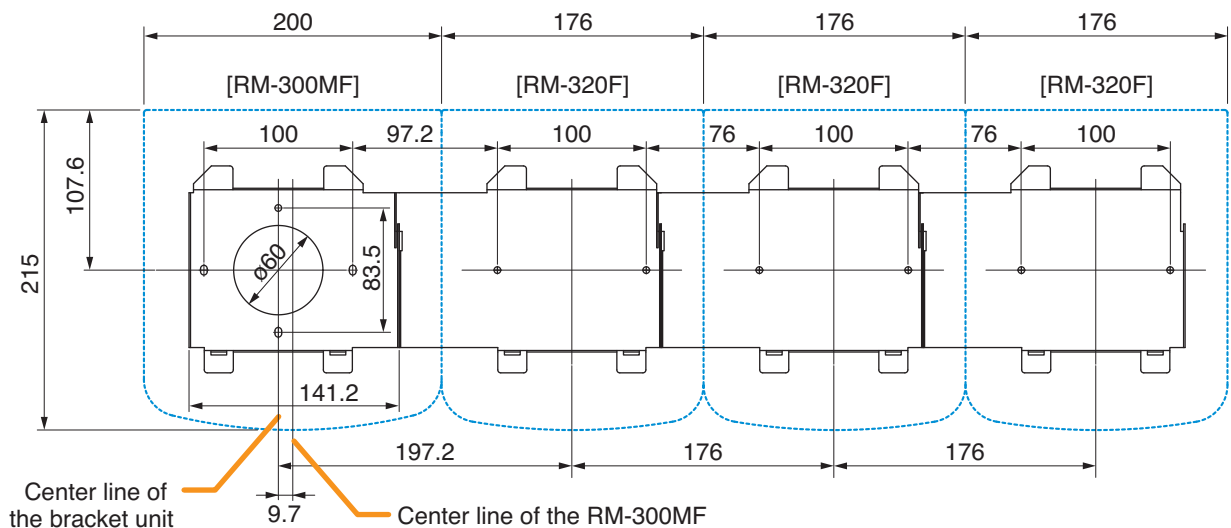

Step 3. Attach the RM-300MF to its wall mount bracket unit. (Refer to [page 93, Steps 3 and 4.](#))

Step 4. Connect the RM-320F's cable to the extension connector on the RM-300MF's side.

Step 5. Install the RM-320F to its wall mount bracket sliding it in close contact with the RM-300MF as shown below.

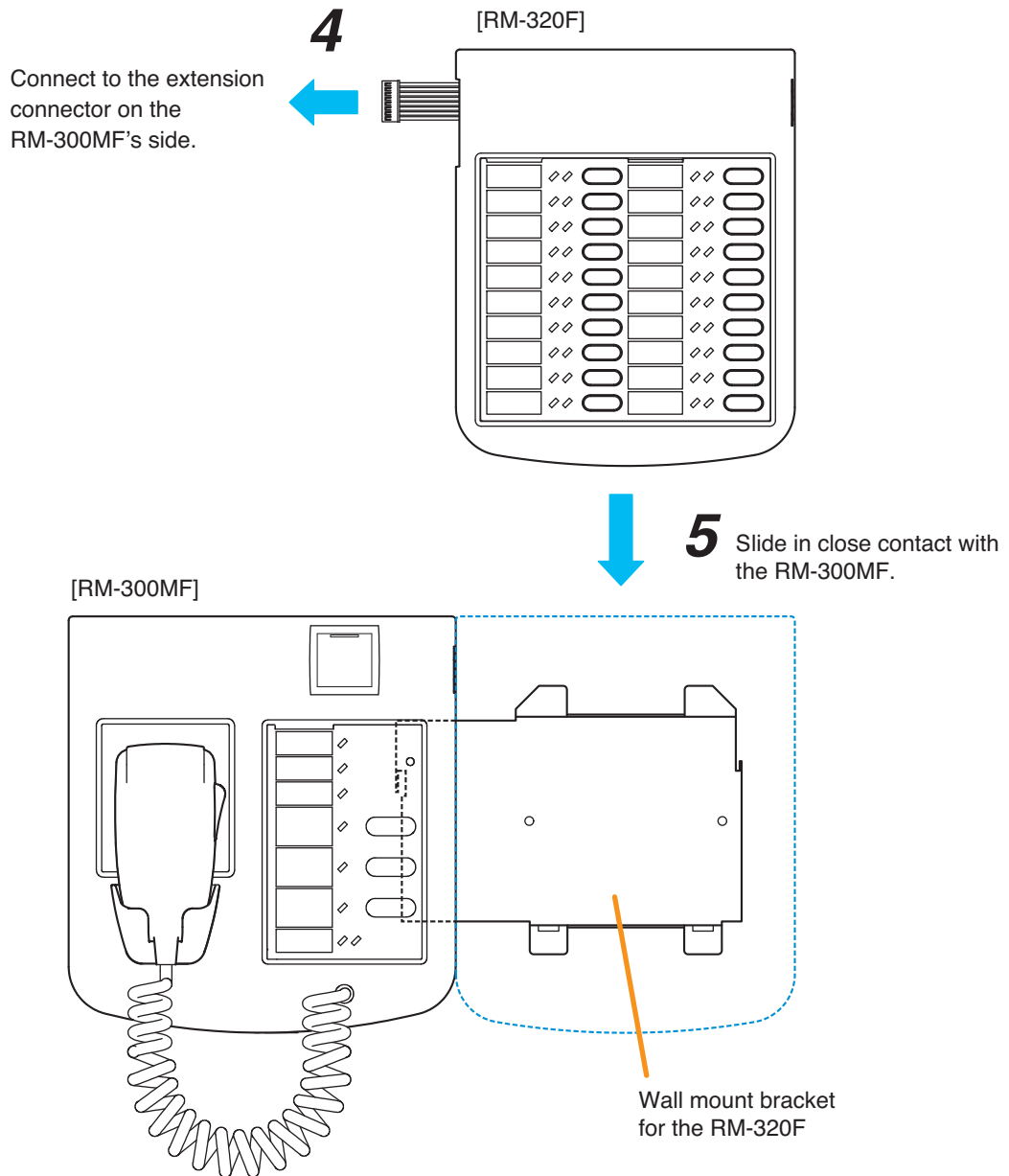

13.3. Installing the RM-200M on a Wall

To mount the RM-200M on the wall, the following parts are required.

WB-RM200 Wall Mounting Bracket for the RM-210	1 (option)
Machine screw M3.5 x 20 (for an electrical box mounting)	2 (supplied with the WB-RM200)
Tapping screw 4 x 25 (for direct wall mounting)	2 (supplied with the WB-RM200)

Step 1. Install the optional WB-RM200 bracket on the wall.
 Pull out the link cable through the bracket's notch.
 As 2 types of supplied screws are available for electrical box mounting and direct wall mounting, use appropriate ones for mounting method.

[Positional dimensions of the WB-RM200]

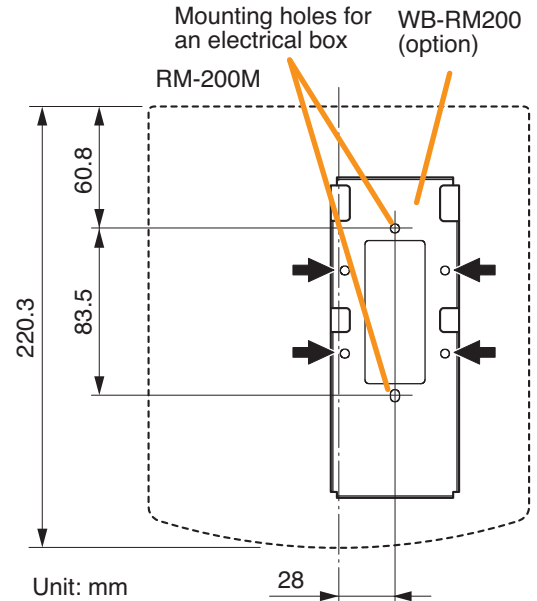

⚠ WARNING

- Install the RM-200M only in a location that can structurally support the weight of the unit and the WB-RM200 bracket. Doing otherwise may result in the unit falling down and causing personal injury and/or property damage.
- Use 2 or more screws to fix the WB-RM200 to the wall.

Step 2. Hook the RM-200M's bottom onto the WM-RM200.

Step 3. Connect the link cable to the RM-200M's link connector.

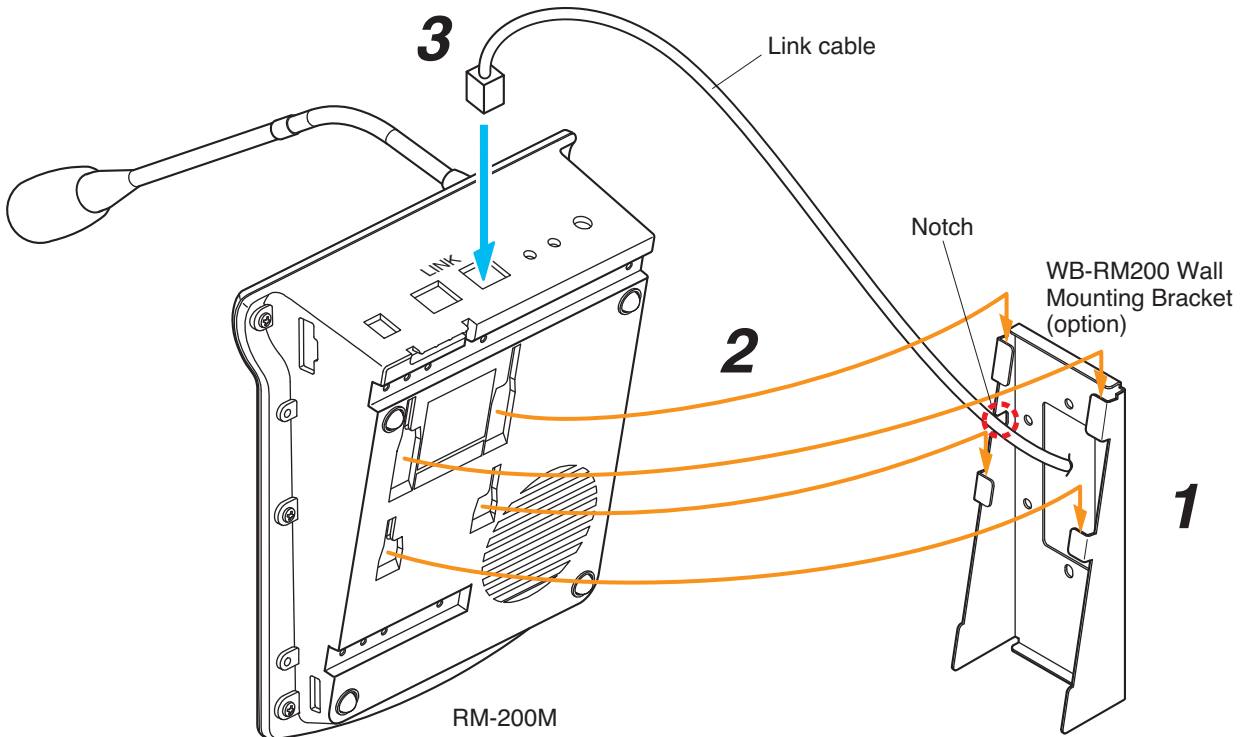

13.4. Installing the RM-210 on a Wall

Step 1. Install the RM-200M on the wall. (Refer to "Installing the RM-200M on a Wall" on page 97.)

Step 2. Install the WB-RM200 used for the RM-210 mounting on the wall.

Step 3. Connect the extension cable supplied with the RM-210 between both extension connectors on the RM-200M's side and the RM-210's side.

Step 4. Hook the RM-210's bottom onto the WB-RM200.

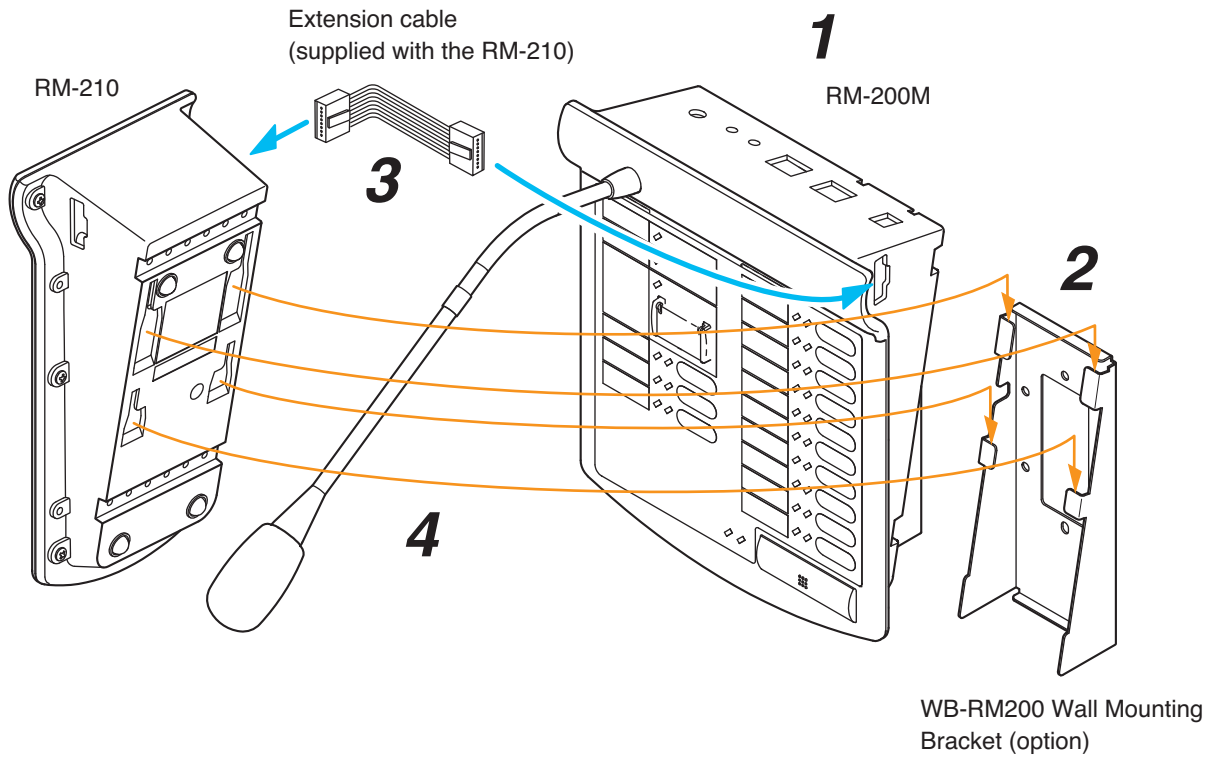

[Positional dimensions of the WB-RM200s]

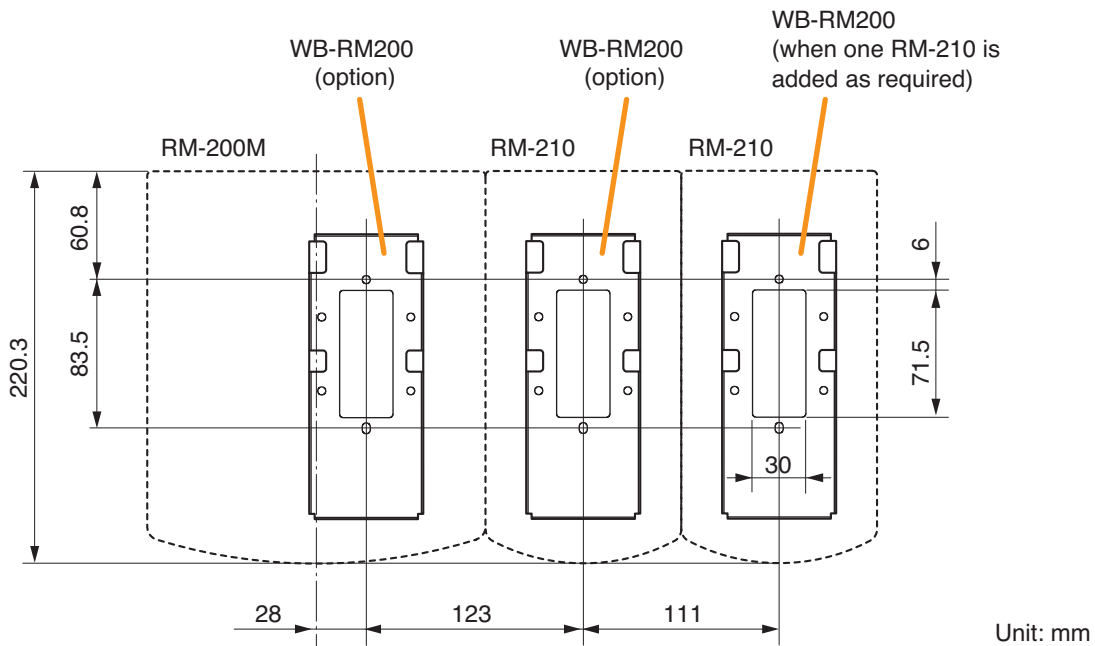

13.5. Linking the RM-200M with the RM-210 (For Desktop Mounting)

To expand the RM-200M by adding the RM-210 Remote Microphone Extension unit, use the parts supplied with the RM-210 shown below to link the 2 units.

Complete the DIP switch settings in advance, then follow the procedure below to link both units.

Linkage Bracket A	2 (supplied with the RM-210)
Linkage Bracket B	1 (supplied with the RM-210)
Tapping screw 3 x 8	12 (supplied with the RM-210)
Extension cable	1 (supplied with the RM-210)

Step 1. Turn over both the RM-200M and the RM-210, and keep them in close contact with each other.

Step 2. Connect the extension cable supplied with the RM-210 between both extension connectors on the RM-200M's side and the RM-210's side.

Step 3. Using the Linkage Bracket B and 4 screws (indicated by arrows in the figure) supplied with the RM-210, link both units together.

Step 4. Using the 2 Linkage Brackets A and 8 screws (indicated by arrows in the figure) supplied with the RM-210, fix both units securely.

Note

Use the same steps above when another RM-210 is added.

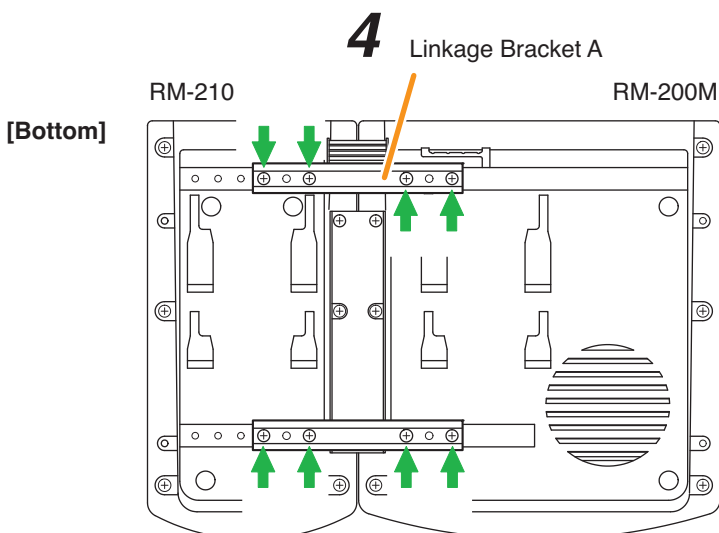
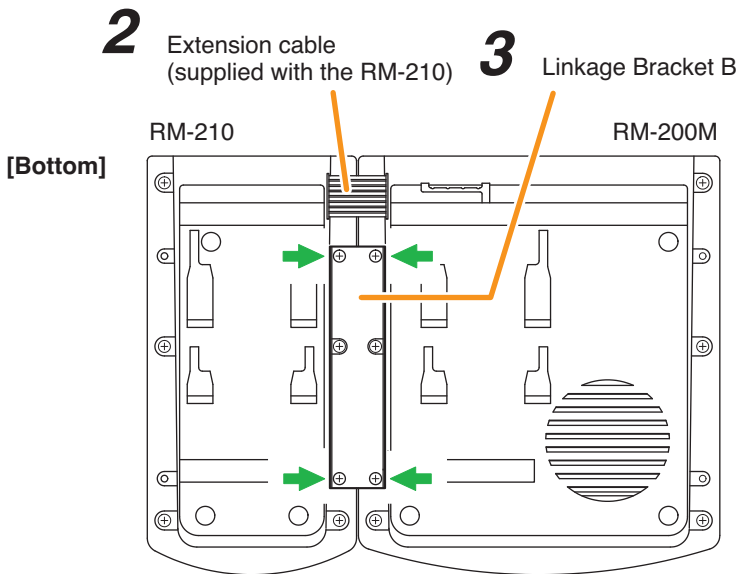

Notes

- As the Linkage Bracket A has 2 spare screw holes, use them to link both units if the designated screw threaded holes are damaged.
- If incorrect or loose cable connection is found between both units, remove all the bracket fixing screws to disassemble the units and reconnect the cable connection correctly. Then, link the units again with the screws.

13.6. Creating Remote Microphone Name Labels

Using the VM-3000 Setting Software function, assigned names of preset RM-300MF, RM-320F, RM-200M, and RM-210 Function keys can be printed out. Once printed, cut out the printed names with scissors to use them as corresponding name labels. The paper used for the name label must be under 0.2 mm in thickness.

Note

For creating and printing name labels using the VM-3000 Setting Software, see the separate Setting Software Instructions, "Labels for Remote Microphones."

13.6.1. Inserting the name label

- Fully insert the name label cut to the instructed size into the label entry slit.
- To remove the label, pull it out of the slit using the tip of knife blade.

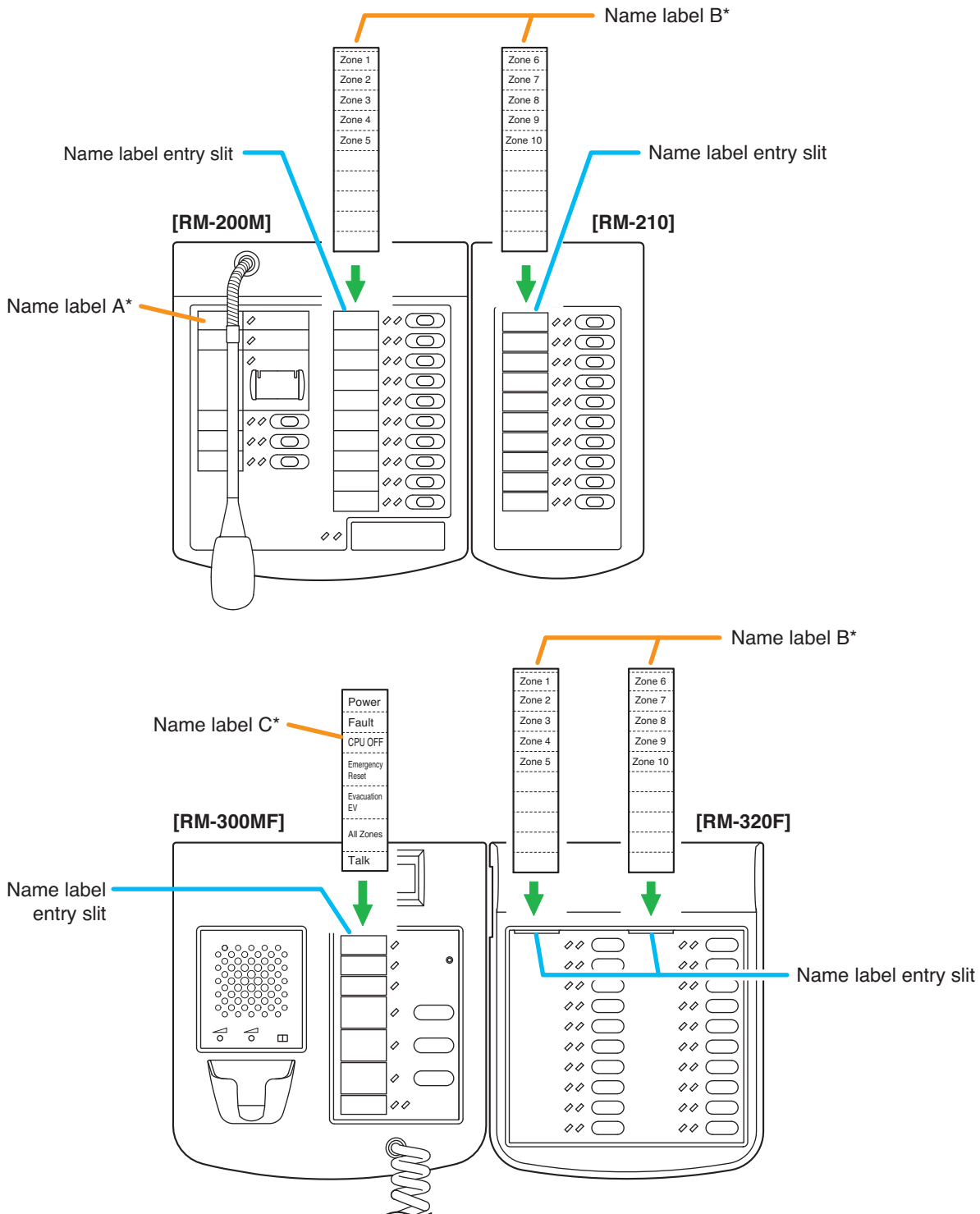

* Created and printed using the VM-3000 Setting Software.

13.6.2. If the name label is not printed correctly

The name label created using the VM-3000 Setting Software may not be printed in correct size depending on the configuration environment of your PC. In such cases, try one of the methods described below.

(1) Preparation by hand

Copy the "Pattern paper for hand writing" on [the next page](#). After writing a name, cut out the pattern paper aligning it with the cutting guidelines.

(2) Preparation by using a PC or word processor

Prepare and print according to the instructions given in the "Dimensional diagram for printing devices." Then cut out to the instructed size.

13.6.3. Dimensional diagram for printing devices

Name label A

Cutting size: 30 x 110 mm

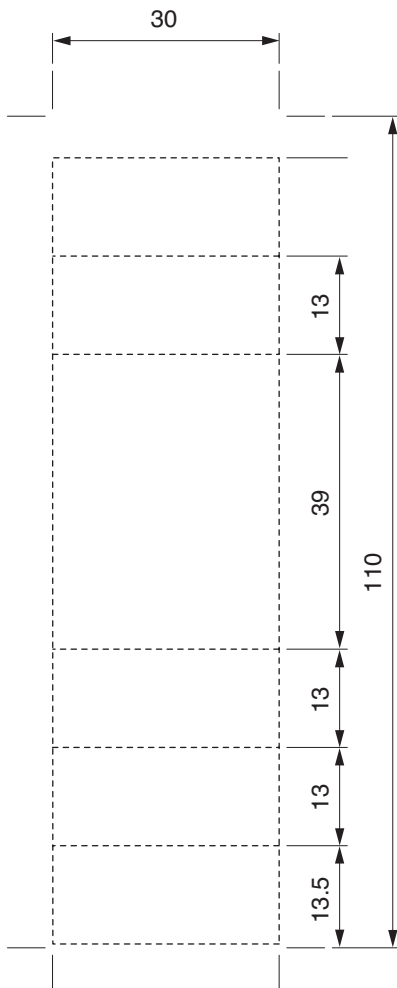

Name label B

Cutting size: 30 x 136 mm

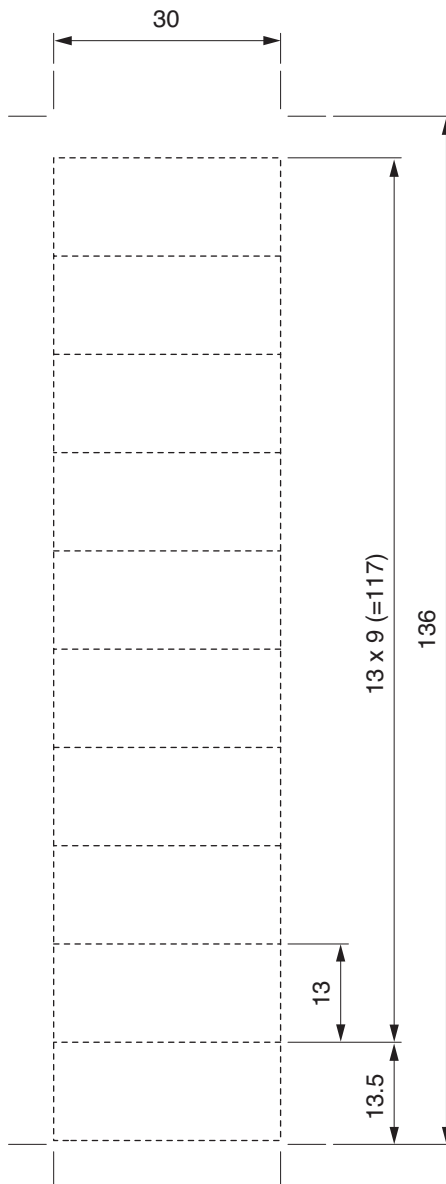

Name label C

Cutting size: 30 x 118 mm

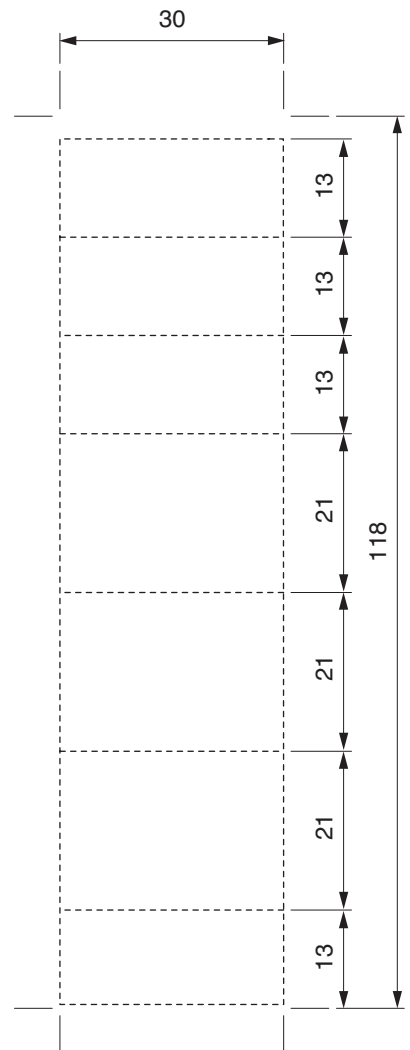

13.6.4. Pattern paper for hand writing

Name label A

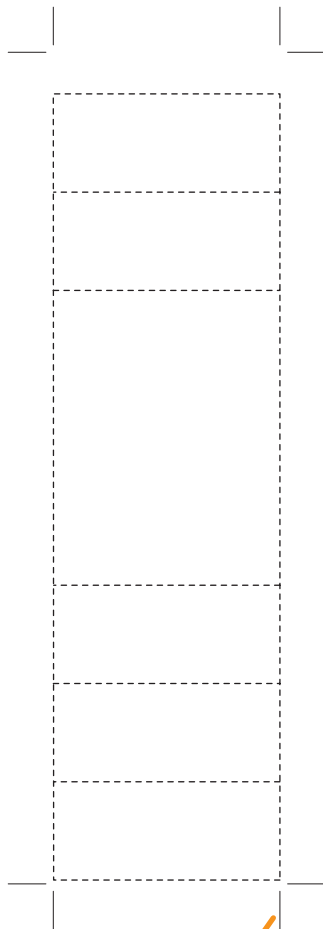

Name label B

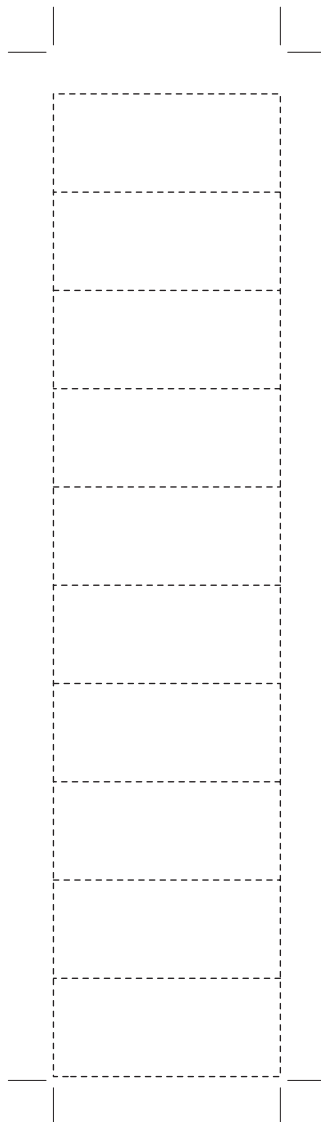

Name label C

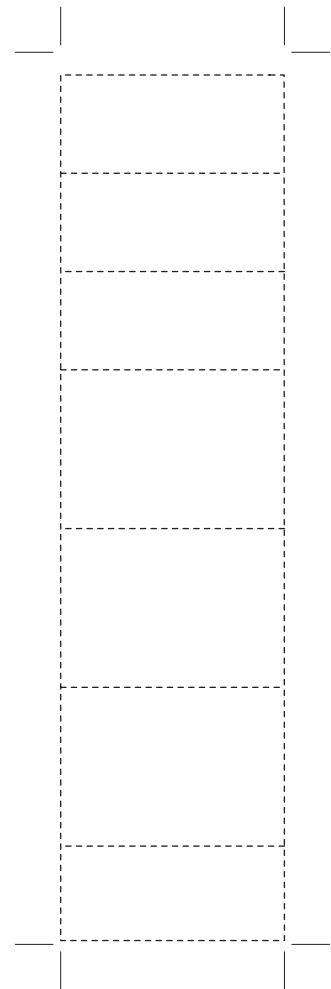

Cutting guideline



Shown in actual size

Name label B

Name label B

Name label B

Name label B

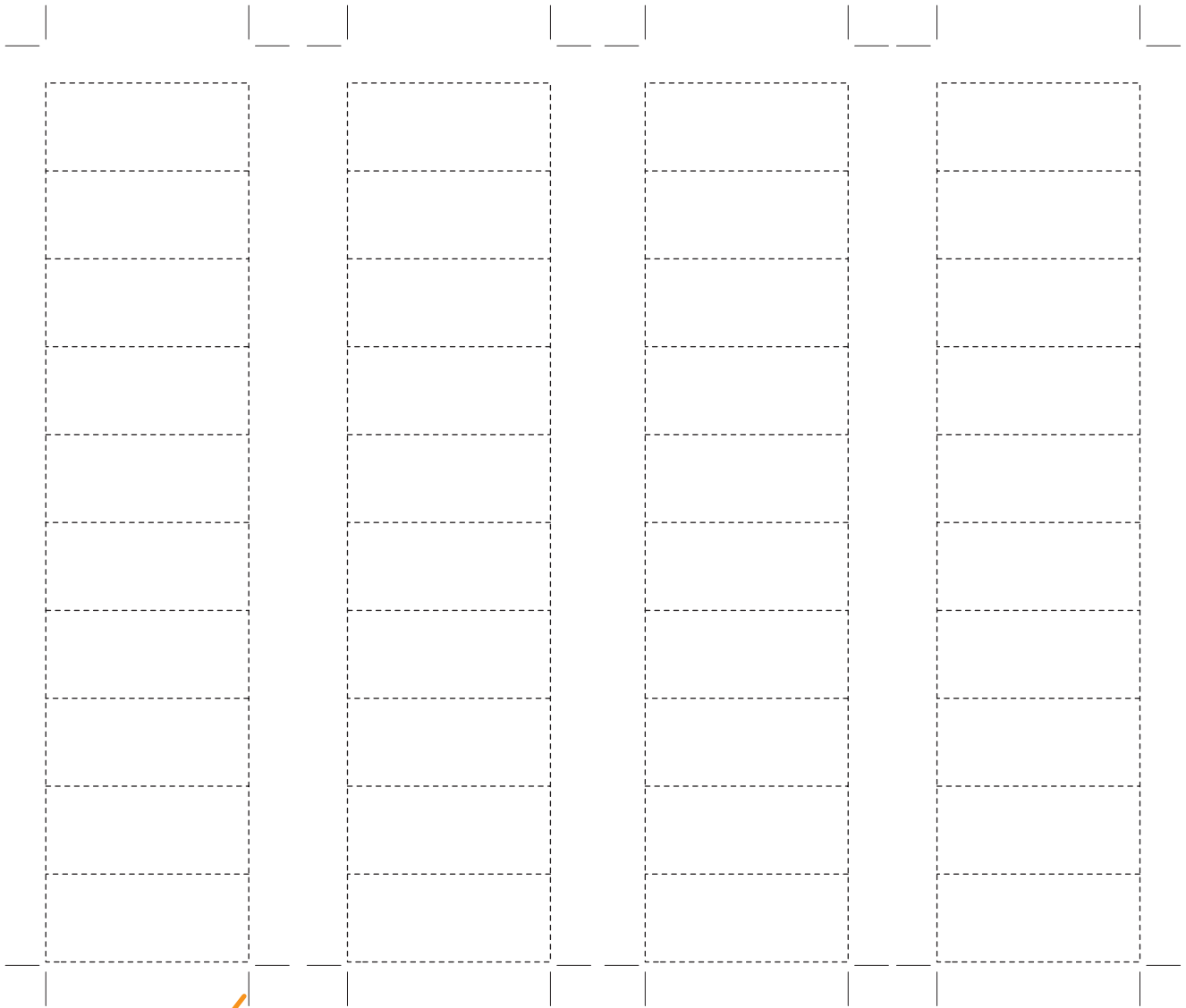

Cutting guideline



Shown in actual size

13.7. Installing the VP-200VX Power Amplifier Input Module in the VP-2241 Power Amplifier

Step 1. Remove the VP-2241 power amplifier's top panel.

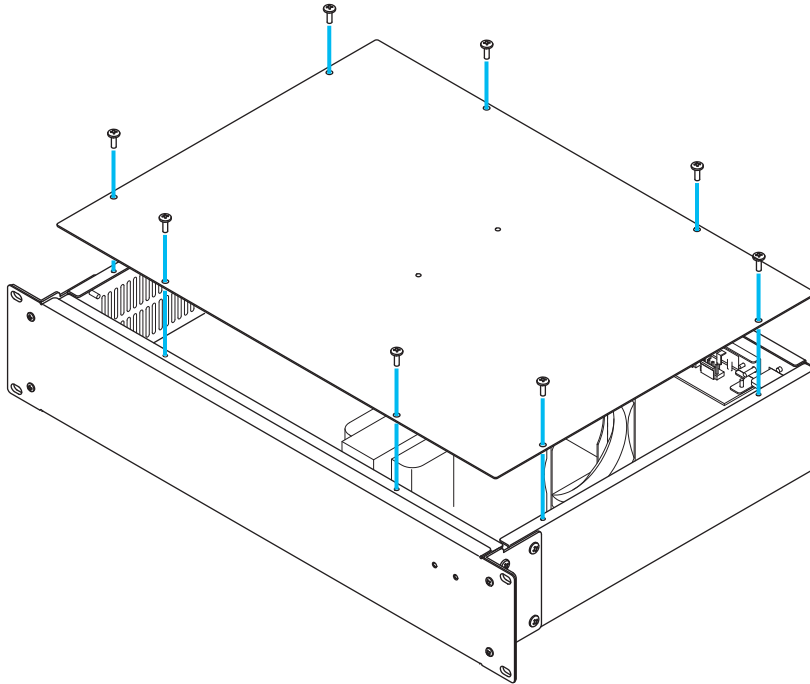

Step 2. Unscrew the VP-200VX's panel to detach it.

Step 3. Mount the VP-200VX module.

Attach the VP-200VX's panel to the mounting location and the VP-200VX unit to the back of the mounting location, then secure them to the amplifier using the screws removed in **Step 2**.

Note: Mount the VP-200VX with its circuit board components faced down.

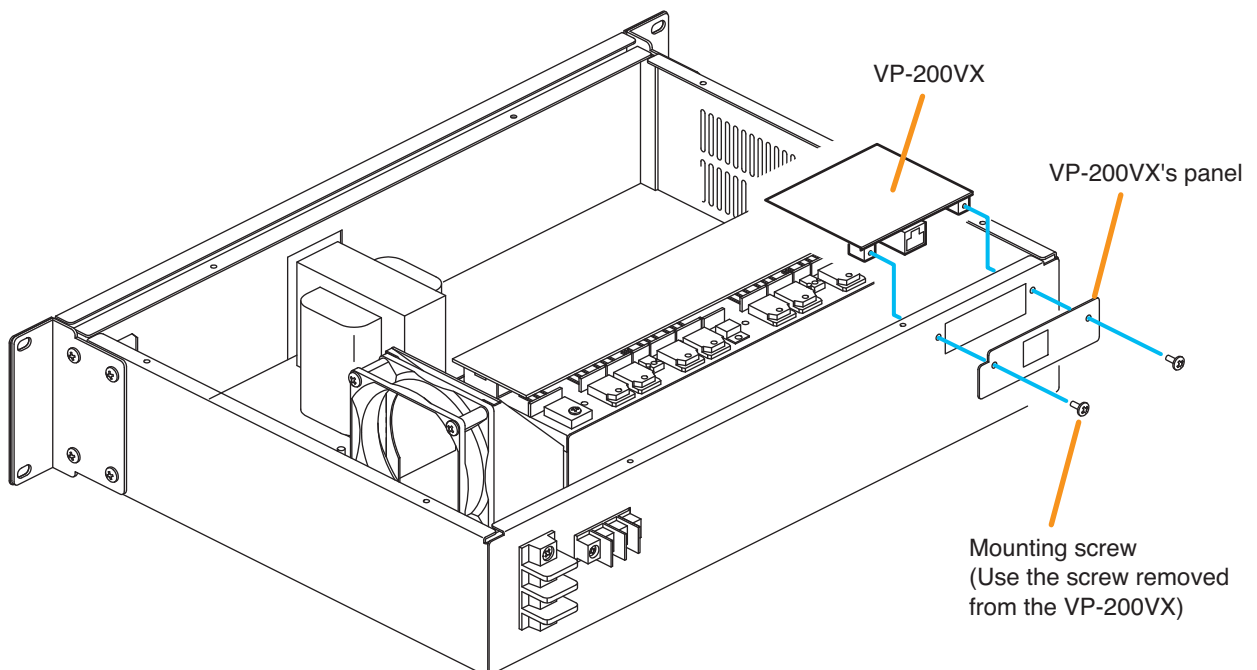

Step 4. Plug the VP-200VX's connector into the CN106 connector on the circuit board inside the amplifier.

[VP-2241 Connector position]

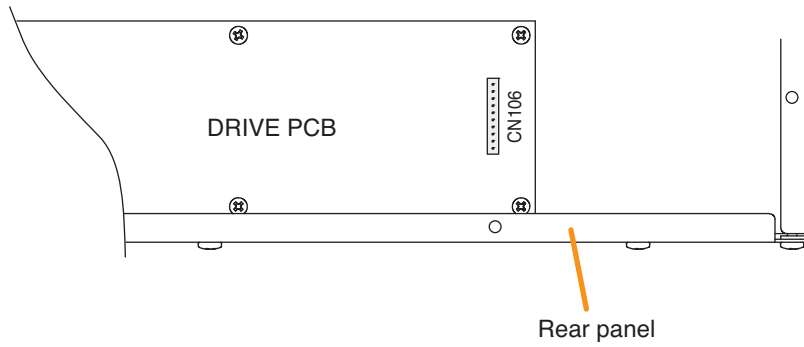

Step 5. After mounting is completed for all required channels, replace the top panel.

13.8. Rack Mounting

Observing the following precautions, mount the equipment in the rack.

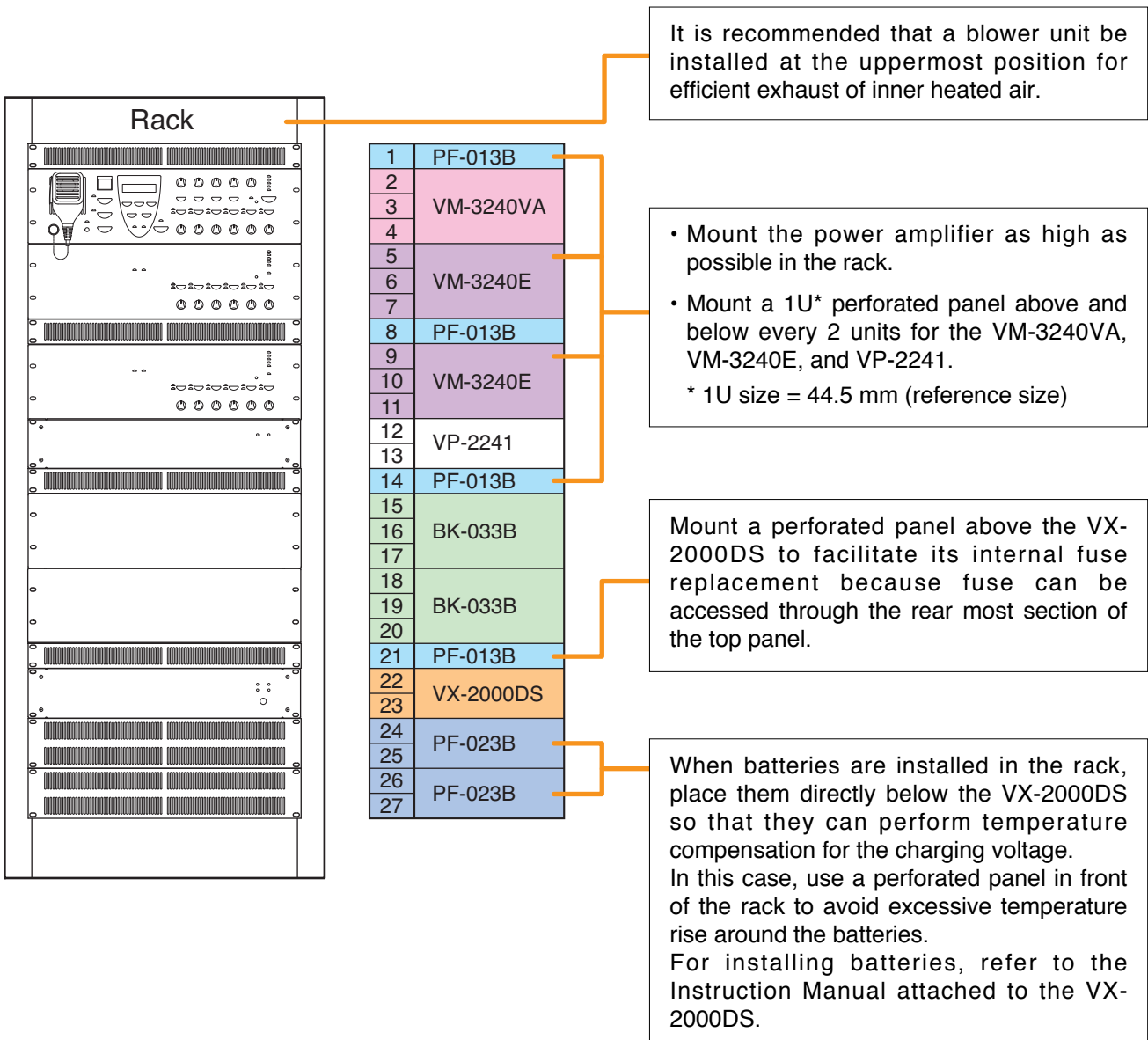

CAUTION

Follow the instructions below. Doing otherwise may cause the unit to fall, possibly resulting in personal injury.

- As the VM amplifiers do not come with rack-mounting screws, prepare locally the screws that are appropriate for the equipment rack.
- The VM-3240VA and VM-3240E can be mounted in an EIA-Standard equipment rack (3 U* size).
 - * 3 U size = 133.5 mm (reference size)
- The rack-mounting screws supplied with the units other than the VM amplifiers are dedicated for the TOA racks. Never use them for any other rack.

Notes

- Because the VM-3240VA, VM-3240E, VP-2241, and VX-2000DS are heavy, use guide rails (separately prepared) in the rack to safely mount and securely support the units.
- The perforated panel is recommended in place of space.

13.9. Desktop Mounting of the VM Amplifiers

Attach the supplied 4 plastic feet to the unit's bottom surface using the supplied screws.

Keep the unit at least 10 cm away from any object as shown below to prevent excessive temperature rise inside the unit.

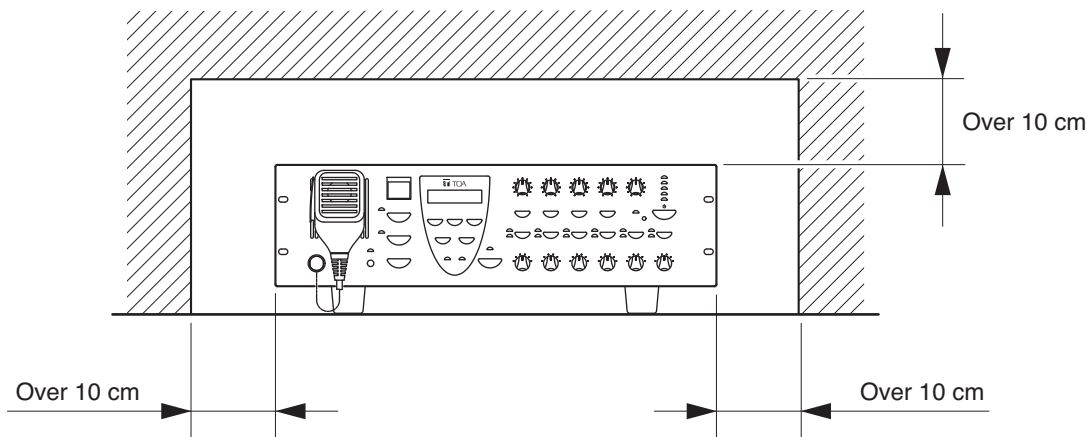

14. CONNECTIONS

14.1. Removable Terminal Plug Connection

Notes

- Do not use a micro screwdriver. Sufficient torque is not given to the screws when tightening them, and connections may not be secured.
- Avoid soldering stranded or shielded cable, as contact resistance may increase when the cable is tightened and the solder is crushed, possibly resulting in an excessive rise in joint temperatures.
- When connecting 2 cables or a shielded cable to a single terminal, use a ferrule terminal with an insulation sleeve to crimp the cables because such cable conductors could become loose.

Recommended ferrule terminals for signal cables
(made by Phoenix Contact)

	Model Number	a	b	l ₁	l ₂
①	AI 0,34-8 TQ	2 mm	0.8 mm	12.5 mm	8 mm
②	AI 0,5-8 WH	2.5 mm	1.1 mm	14 mm	8 mm

Recommended ferrule terminals for power supply cables
(made by Phoenix Contact)

	Model Number	a	a ₁	a ₂	b	l ₁	l ₂
③	AI 1,5-8 BK	3.4 mm	—	—	1.8 mm	14 mm	8 mm
④	AI-TWIN 2 x 1,5-8 BK	—	6.6 mm	3.6 mm	2.3 mm	16 mm	8 mm

Crimping tool: CRIMPFOX UD6-4 (made by Phoenix Contact)

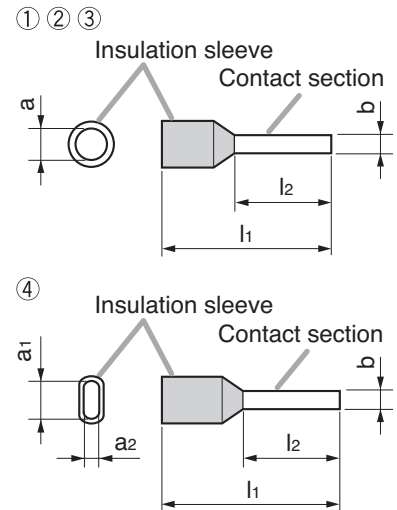

Cable sheath to trim

Solid cable and stranded cable

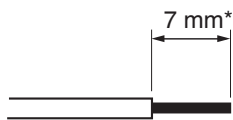

Shielded cable

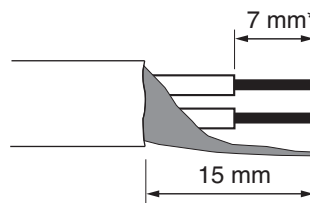

* Expose 8 mm or more when using the above ferrule terminal, and cut off an extra conductor protruding from the sleeve.

Wiring procedures

Procedures below are for the removable terminal plug with fixing screws.

Step 1. Loosen the terminal screw and insert the cable lead.

Step 2. Tighten the screw.

Pull on the cable lead to ensure it is securely connected.

If the lead pulls out, loosen the screw and follow the above procedures again.

Step 3. Insert the terminal plug into the corresponding terminal block in the unit's rear panel.

Note

Do not reverse Steps 1 – 2 and 3 above.

Force is applied to the connected receptacle pins while tightening the terminal screw and they may be damaged, resulting in bad connector contact.

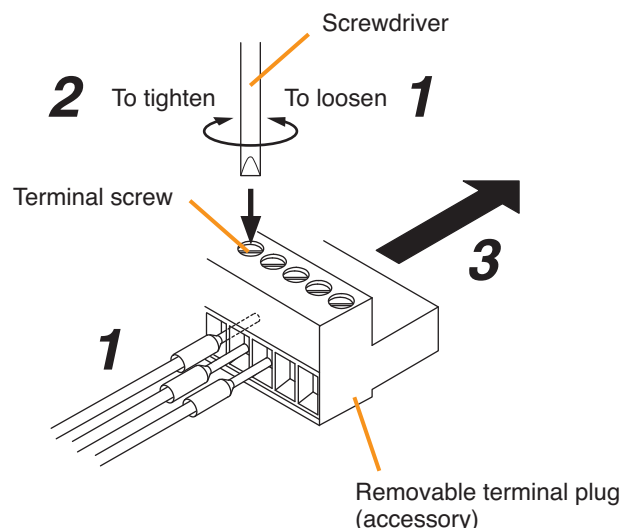

14.2. Audio and Control Connection Example

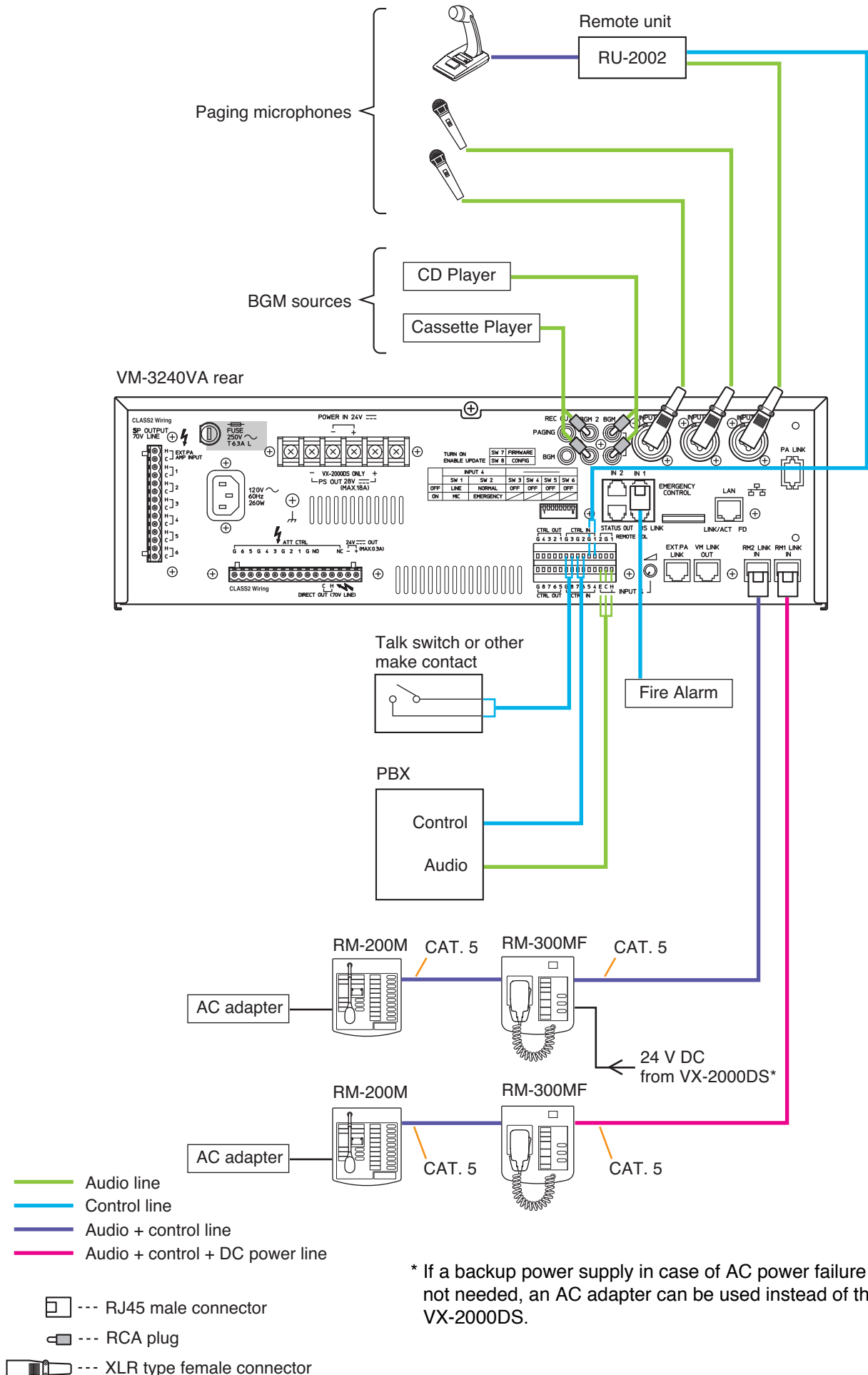

14.3. Remote Microphone Connections

14.3.1. Power supply and limit on the number of remote microphones

The number of remote microphones connectable in a system is as follows.

- Up to 2 RM-300MFs can be connected to the VM-3240VA. Besides, up to 4 RM-200Ms and RM-300MFs in total can be connected.
- Up to 3 RM-320Fs can be connected to the RM-300MF, and up to 4 RM-210s to the RM-200M.

The method of power supply to the remote microphones differs depending on the system application and configuration, and also type of remote microphone. In a system configuration, the allowable number of the microphones connected to the VM-3240VA may be limited.

[Power supply to the remote microphones]

Note

Red lines are DC power lines.

- The VM-3240VA can supply power to a single RM-300MF or RM-200M only.

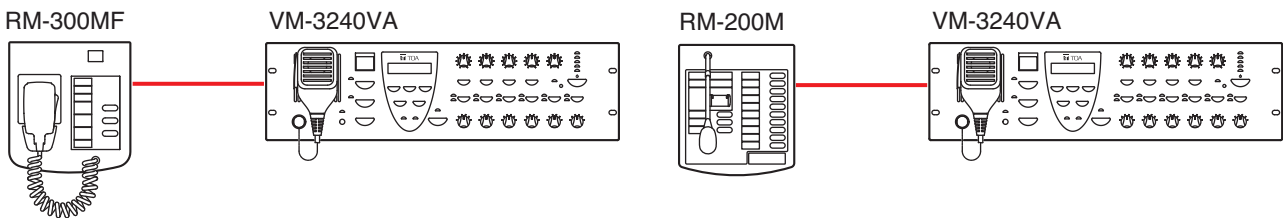

- When installing a second or subsequent remote microphones or an expansion unit of the RM-320F or RM-210, a separate power supply unit is required. In this case, An AC adapter can be used for the RM-200M/210, and an AC adapter or the VX-2000DS for the RM-300MF/320F.

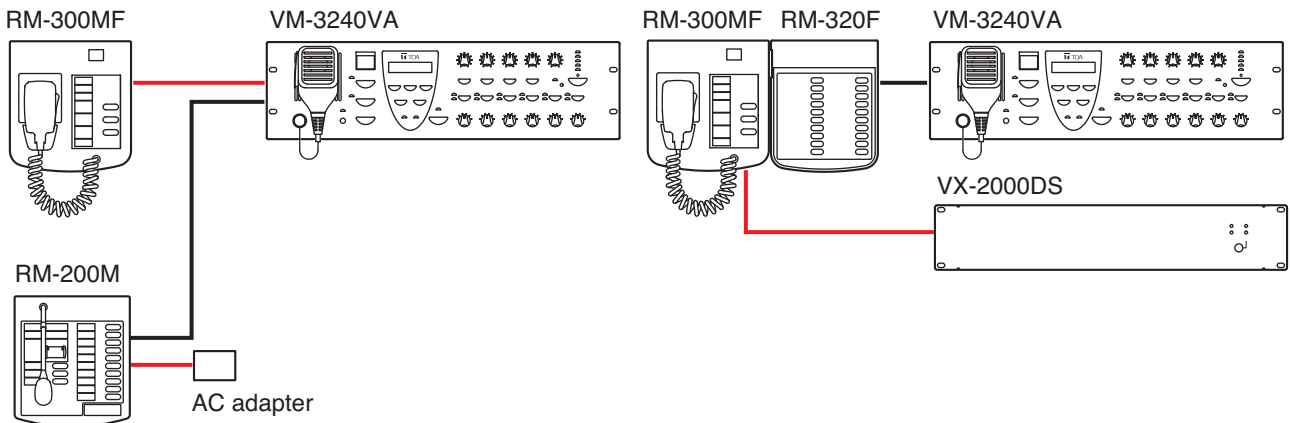

- By supplying power to the RM-300MF/320F from the VX-2000DS, the RM-300MF/320F can be operated on the backup power even in case of AC power failure.

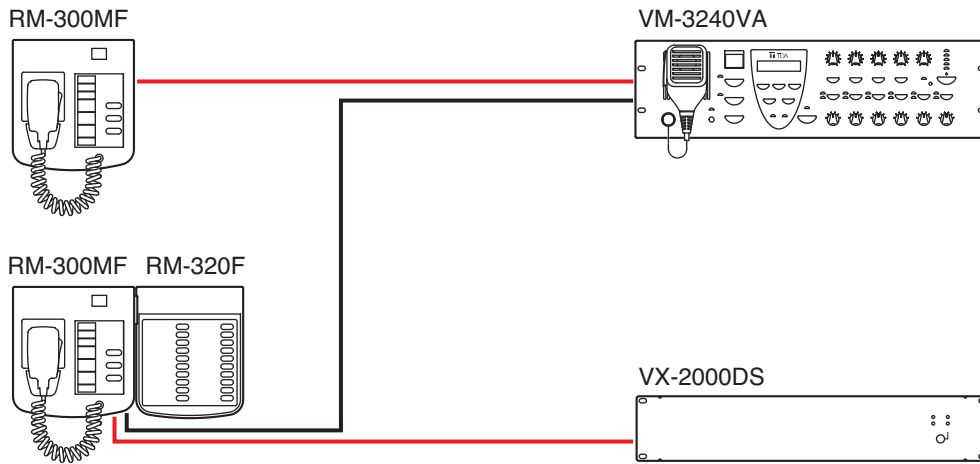

[Limit on the number of remote microphones]

Note

Red lines are DC power lines.

In a system consisting of a single VM-3240VA without VM-3240E, when the VX-2000DS Emergency Power Supply unit supplies power to the RM-300MF/320F, the connectable number of the RM-320Fs is reduced, being up to 2 RM-320Fs.

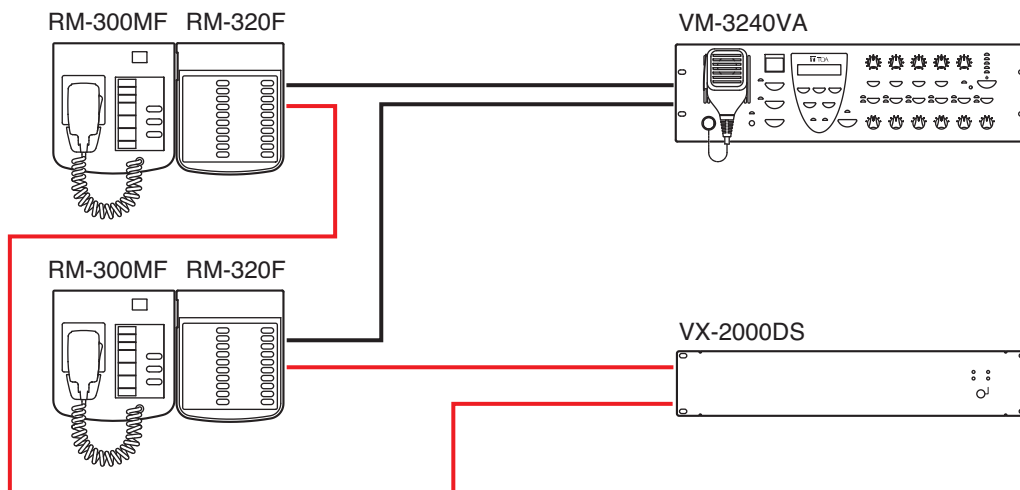

14.3.2. RM-300MF connection

Connect the RM-300MF to either of the RM1 LINK IN or RM2 LINK IN connector of the VM-3240VA.

[When power is supplied from the VM-3240VA]

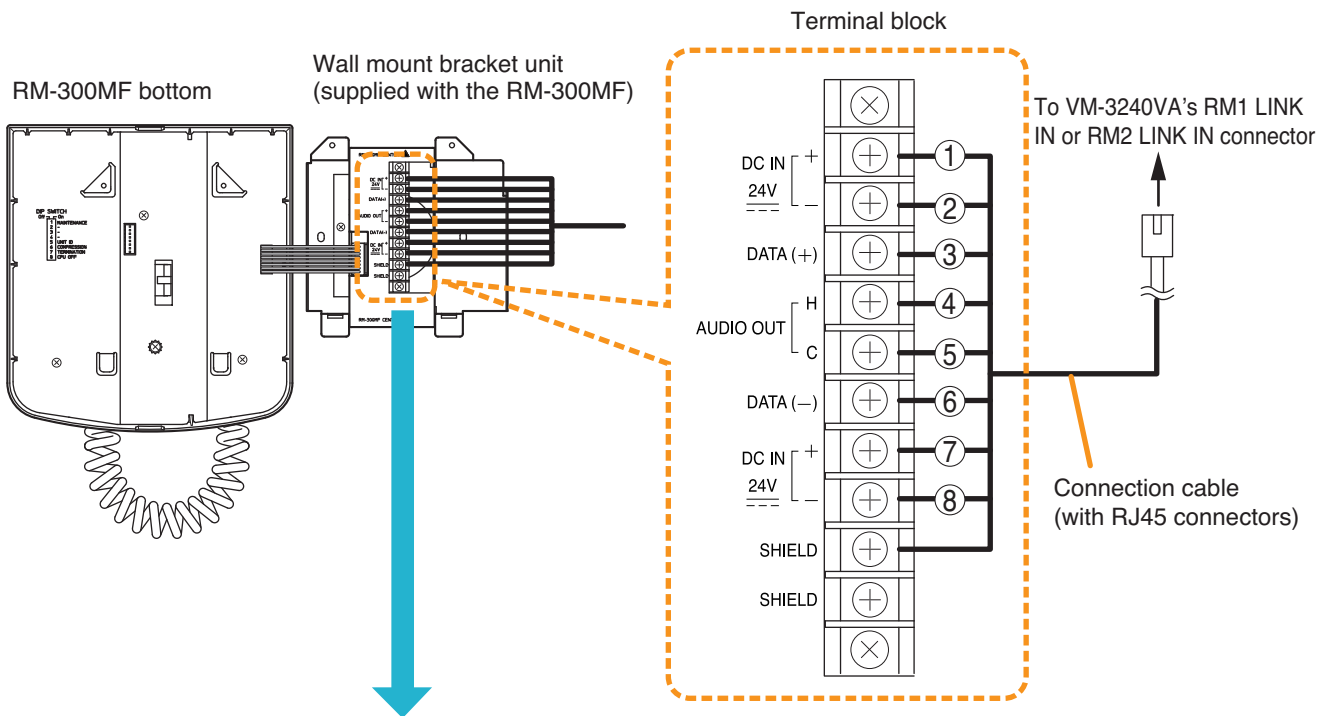

Wall mount bracket unit (supplied with the RM-300MF)	RJ45 connector pin No.	Cable color (T568B type)	Cable color (T568A type)
DC IN 24 V (+)	①	Orange/White	Green/White
DC IN 24 V (-)	②	Orange	Green
DATA (+)	③	Green/White	Orange/White
AUDIO OUT (H)	④	Blue	Blue
AUDIO OUT (C)	⑤	Blue/White	Blue/White
DATA (-)	⑥	Green	Orange
DC IN 24 V (+)	⑦	Brown/White	Brown/White
DC IN 24 V (-)	⑧	Brown	Brown
SHIELD	Shield	—	—

- The following table shows the maximum cable distance when STP Category 5 straight cable (with RJ45 connectors) is used.

Cable	No. of expansion units	RM-300MF alone
STP Category 5		140 m

- To make longer cable lengths than those shown in the above table, use over 4-pair shielded CPEV cable. The relationship of the CPEV cable conductor diameter to the maximum cable distance is as follows:

Conductor diameter	No. of expansion units	RM-300MF alone
ø0.65 mm		230 m
ø0.9 mm		460 m
ø1.2 mm		800 m

[When power is supplied from the VX-2000DS or AC adapter]

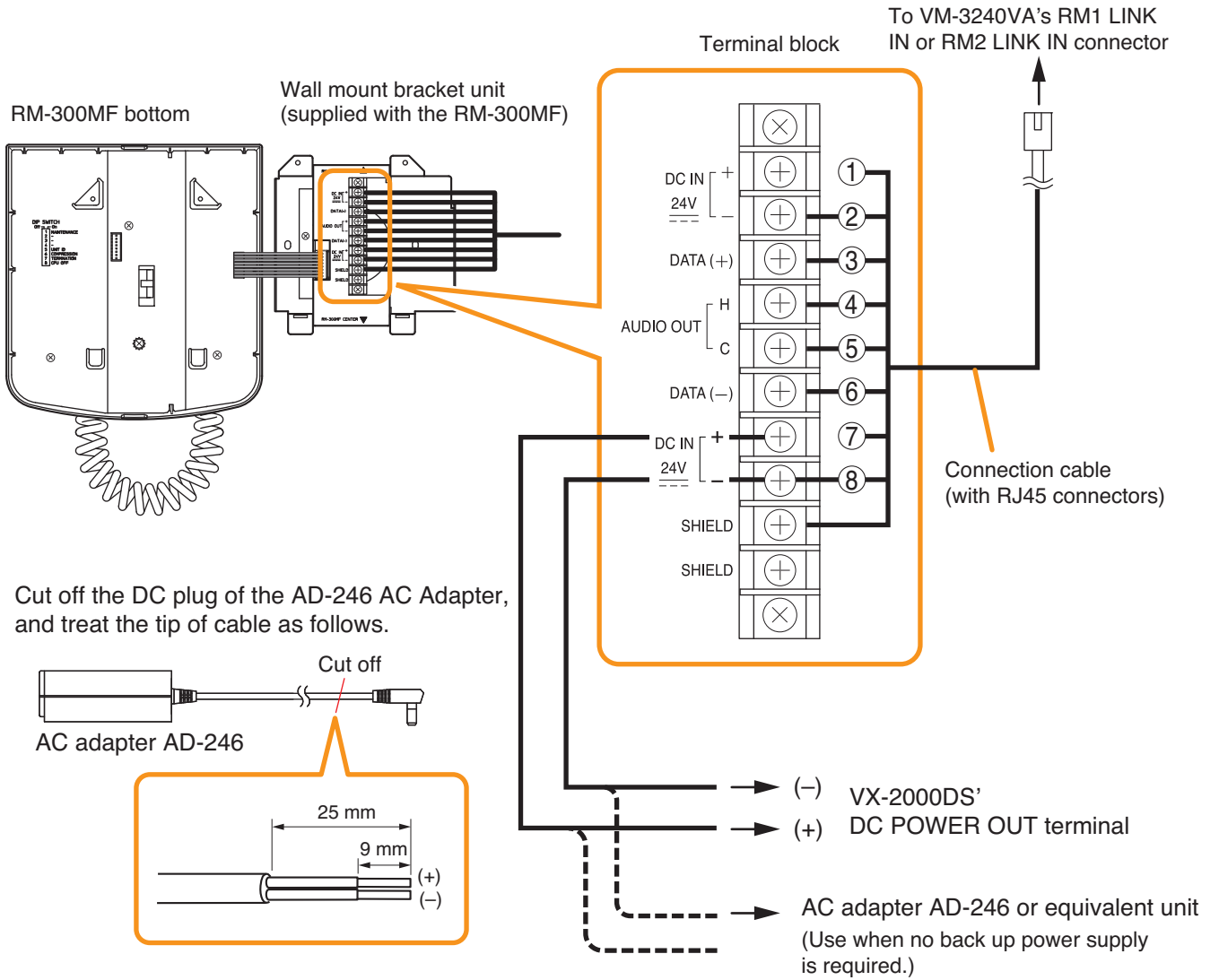

- * Usable AC adapter
 - 24 V DC/over 200 mA (Operation range: 14 – 28 V DC)
 - Usable power input plug: Non-polarity type (5.5 mm outer diameter, 2.1 mm inner diameter, and 9.5 mm long)

When a STP Category 5 straight cable is used as communication cable (excluding power line) between the RM-300MF and the VM-3240VA, the maximum cable distance in a system is 800 m in total.

The maximum distance of power cable between the RM-300MF and the VX-2000DS is as follows.

- The following table shows the maximum cable distance when STP Category 5 straight cable (with RJ45 connectors) is used.

Cable	No. of expansion units			
	RM-300MF alone	RM-300MF + RM-320F x 1	RM-300MF + RM-320F x 2	RM-300MF + RM-320F x 3
STP Category 5	140 m	100 m	80 m	60 m

- To make longer cable lengths than those shown in the above table, use over 4-pair shielded CPEV cable. The relationship of the CPEV cable conductor diameter to the maximum cable distance is as follows:

Conductor diameter	No. of expansion units			
	RM-300MF alone	RM-300MF + RM-320F x 1	RM-300MF + RM-320F x 2	RM-300MF + RM-320F x 3
ø0.65 mm	230 m	170 m	130 m	90 m
ø0.9 mm	460 m	330 m	260 m	200 m
ø1.2 mm	800 m	570 m	450 m	350 m

14.3.3. RM-200M connection

- The RM-200M is equipped with 2 link connectors, either of which can be used for connection.
- To connect an additional RM-200M, use either link connector.
- When connecting only RM-200Ms to the VM-3240VA, a total of 4 RM-200Ms can be connected to the VM-3240VA's RM1 LINK IN and RM2 LINK IN connectors.

[When power is supplied from the VM-3240VA]

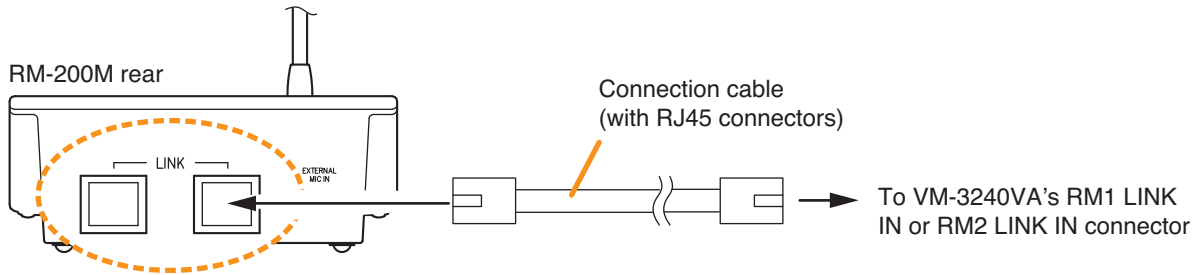

- The following table shows the maximum cable distance when STP Category 5 straight cable (with RJ45 connectors) is used.

Cable	No. of expansion units	RM-200M alone
STP Category 5		140 m

- To make longer cable lengths than those shown in the above table, use over 4-pair shielded CPEV cable. (For the cable connection, see below.)

The relationship of the CPEV cable conductor diameter to the maximum cable distance is as follows:

Conductor diameter	No. of expansion units	RM-200M alone
ø0.65 mm		230 m
ø0.9 mm		460 m
ø1.2 mm		800 m

[When power is supplied from the AC adapter]

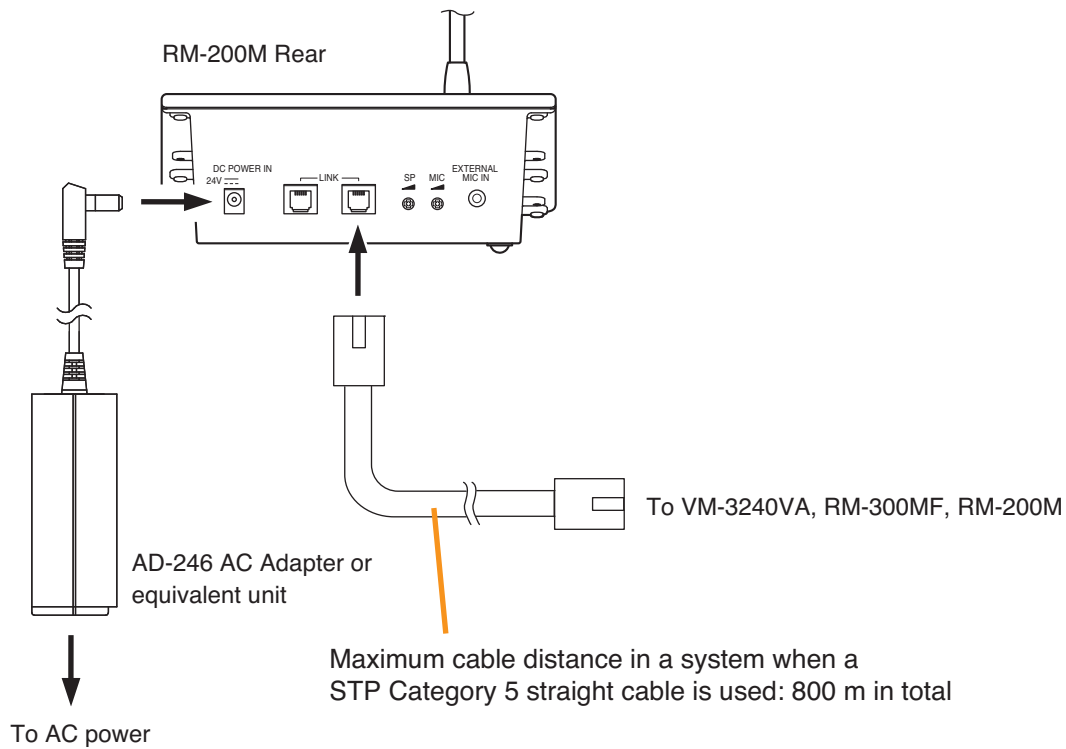

*** Usable AC adapter**

24 V DC/over 200 mA (Operation range: 14 – 28 V DC)

Usable power input plug: Non-polarity type

(5.5 mm outer diameter, 2.1 mm inner diameter, and 9.5 mm long)

Note

Plugging a DC plug into the RM-200M's DC POWER IN terminal automatically switches the RM-200M's DC power input to this terminal, disconnecting the unit's power supply from the LINK connector.

Be sure to firmly secure the DC plug by fixing the power cable onto the RM-200M's bottom-mounted cable hook.

If the DC plug is pulled out, the LINK connector takes over the unit's power supply and is connected to the system power line. This may cause the voltage drop of power supply and increase the current consumption from the VM-3240VA, resulting in the system malfunction.

14.3.4. Connections between RM-300MF and RM-200M

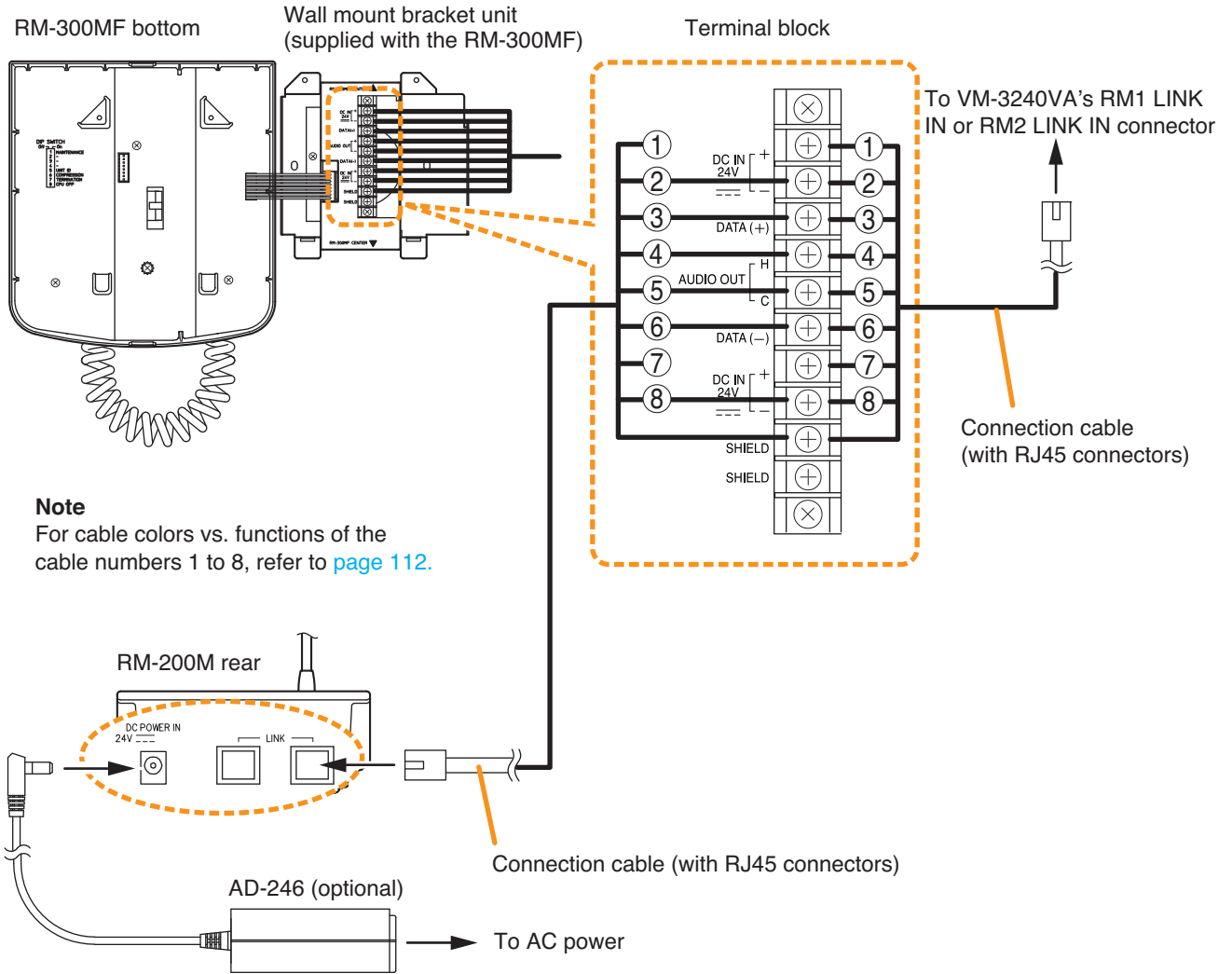

Notes

- The RM-200M is equipped with 2 link connectors, either of which can be used for connection.
- A total of 2 RM-300MFs can be connected to the VM-3240VA's RM1 LINK IN or RM2 LINK IN connector. Besides, up to 4 RM-200Ms and RM-300MFs in total can be connected.
- When STP Category 5 straight cable is used to connect between the VM-3240VA and remote microphones, the maximum cable distance in a system is 800 m in total.

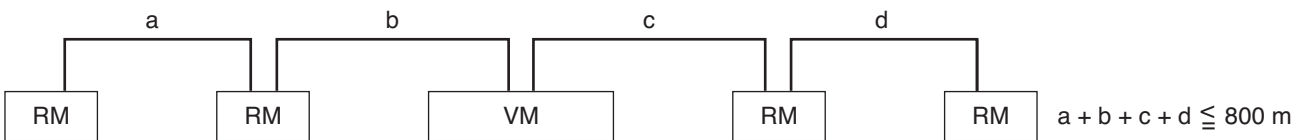

RM: RM-300MF/320F or RM-200M/210

VM: VM-3240VA

14.4. General Control Input Terminal Connections

14.4.1. Controlling functions assigned to the General Control Input terminals from the external equipment

Following are assignable functions to the General Control Input terminals. (For the function assignments, refer to "General control input settings" in "Event Settings" in the separate software instruction manual.)

- VA-INPUT 1 – 4: Allows general broadcast received from the designated input to the designated output (zone).
- EV 1 – 6: The designated pre-recorded general message announcement is automatically broadcast to the designated output (zone).
- Power ON/OFF: Functions as the front-panel mounted Power switch by use of the control input.
- Failure Receipt: Acknowledges a failure and causes all currently sounding buzzers to stop. At the same time, it switches the Failure indicator from flashing to steady on mode.
- Failure output reset: Resets the failure status.
- External failure input: Captures failure information having occurred outside the system by use of the control input, causing the buzzers to sound in the VM-3000 system, and displaying the information on the LCD screen.

VM-3240VA/3240E rear

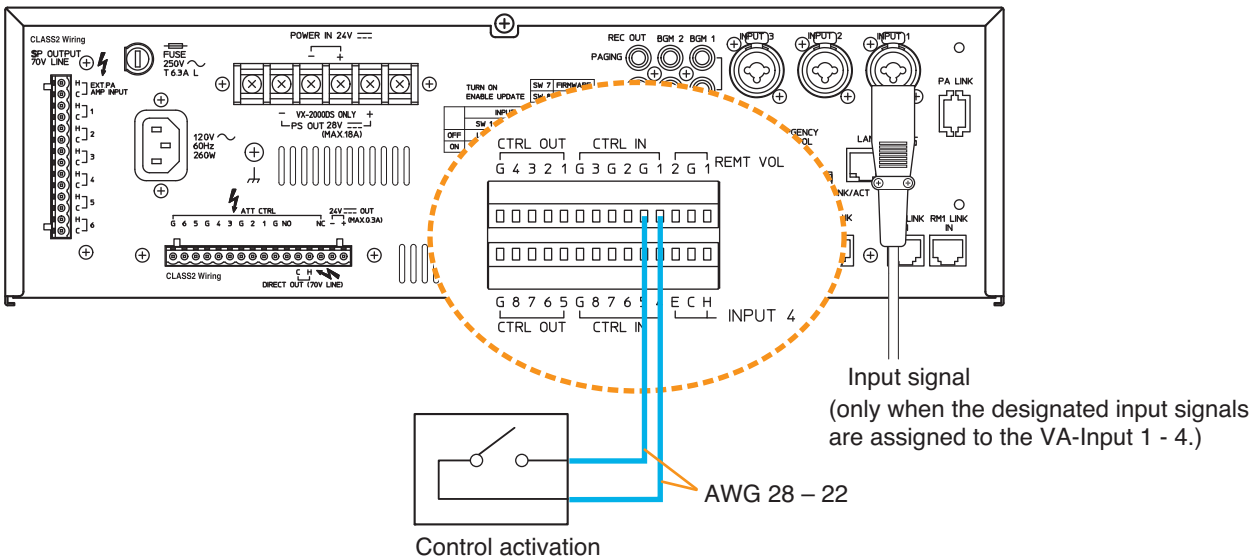

[Setting example]

Shown below is a general control input setting screen in the setting software. The figure shows an example when performing a general broadcast by way of the contact activation.

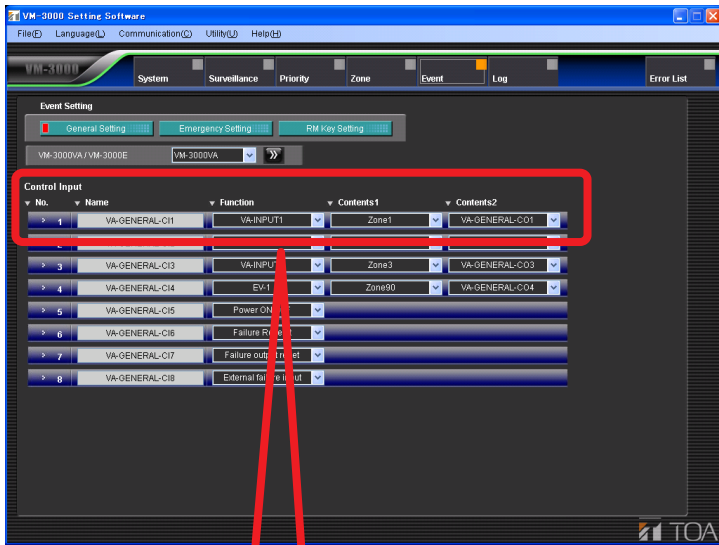

Control input	No. 1
Sound source input	VA-INPUT 1
Broadcast zone	Zone 1
Interlocked control output	No. 1



14.4.2. Using the local input

Local broadcasts can be performed within the area where the unit covers using the VM-3240E's Local input. To use this function, refer to "Local input settings" in "System settings" in the separate software instruction manual.

VM-3240E rear

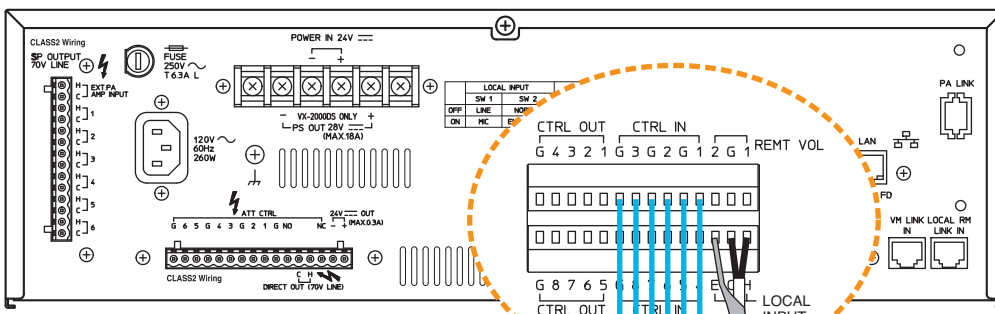

Relation between Control inputs and broadcast output destinations

Control input	Broadcast output destination
CTRL 1	OUTPUT1
CTRL 2	OUTPUT2
CTRL 3	OUTPUT3
CTRL 4	OUTPUT4
CTRL 5	OUTPUT5
CTRL 6	OUTPUT6
CTRL 7	OUTPUT1-6
CTRL 8	Not used.

AWG 28 – 22

Local Input

E C H

SUB SW2 SW1

When using a single-core shielded cable, connect the shielded mesh to both E and C terminals.

14.4.3. Example of connection to external equipment

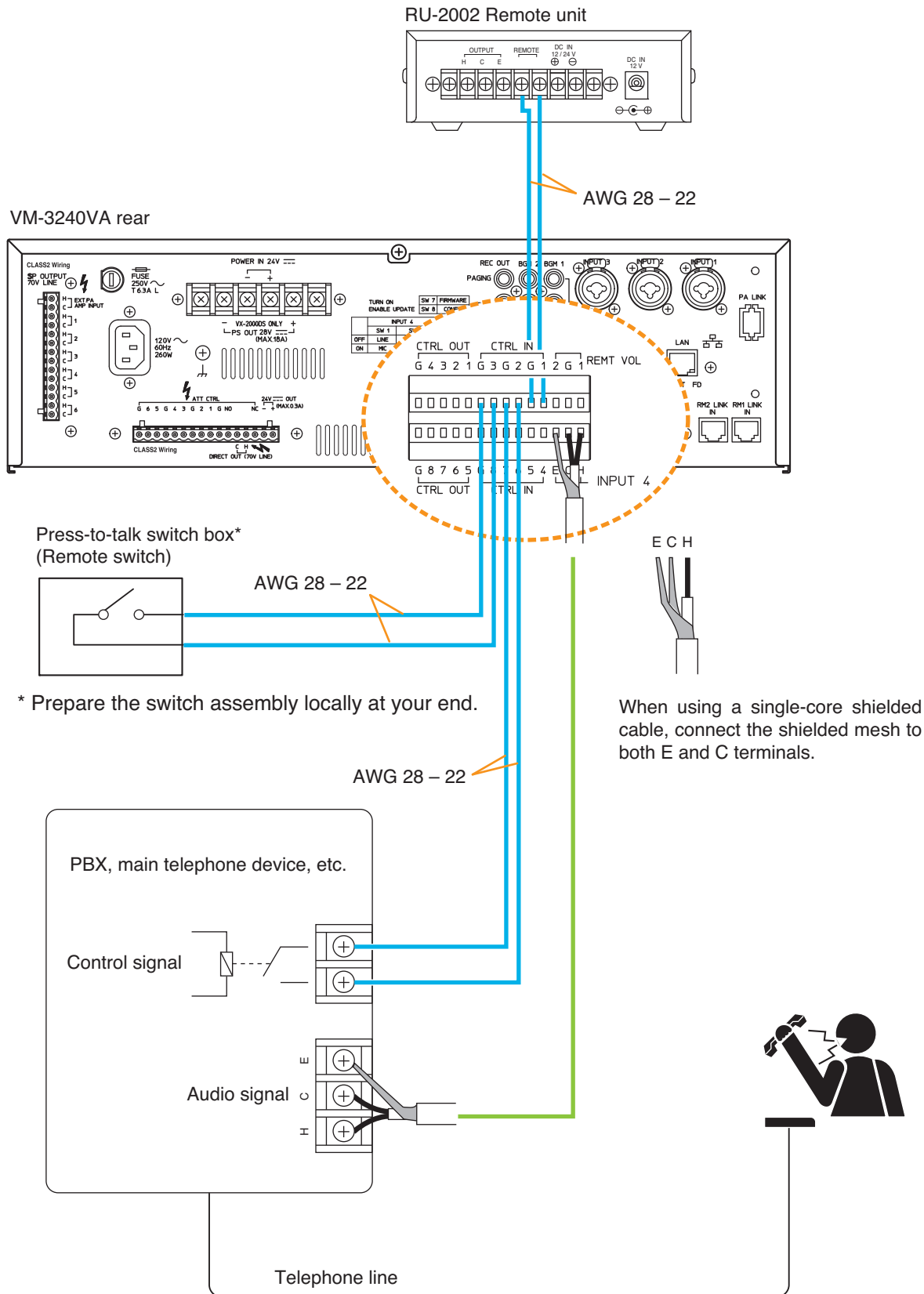

14.5. Emergency Control Input Terminal Connections

Following are assignable functions to the Emergency Control Input terminals. (For the function assignments, refer to "Emergency control input settings" in "Event settings" in the separate software instruction manual.

- Evacuation EV broadcast: Broadcasts the evacuation message internally pre-recorded on the VM-3240VA to the designated output (zone).
- Evacuation EV stop: Stops Evacuation EV broadcast.
- Alert EV broadcast: Broadcasts the Alert message internally pre-recorded on the VM-3240VA to the designated output (zone).
- Alert EV stop: Stops Alert EV broadcast.
- Emergency Reset: Resets the system from emergency mode.
- Amplifier Cut off: Cuts off the VM-3000 system's built-in amplifier and switches to the broadcast made using the external system.
- End of line: This function cannot be used.

[Setting example]

Shown below is an Emergency control input setting screen in the setting software. The figure shows an example when performing an emergency broadcast by way of control activation.

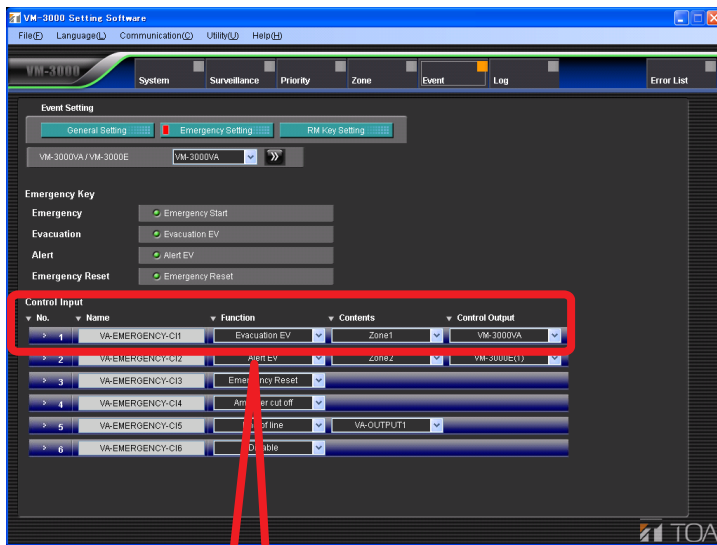

Control input	No. 1
Sound source input	Evacuation EV
Broadcast zone	Zone 1
Control output	VM-3000VA



14.5.1. External emergency control equipment connection

An emergency broadcast (Evacuation EV or Alert EV) can be activated by external controls such as an automatic fire alarm activation signal.

To reset the emergency status, press the Emergency Reset switch.

VM-3240VA rear

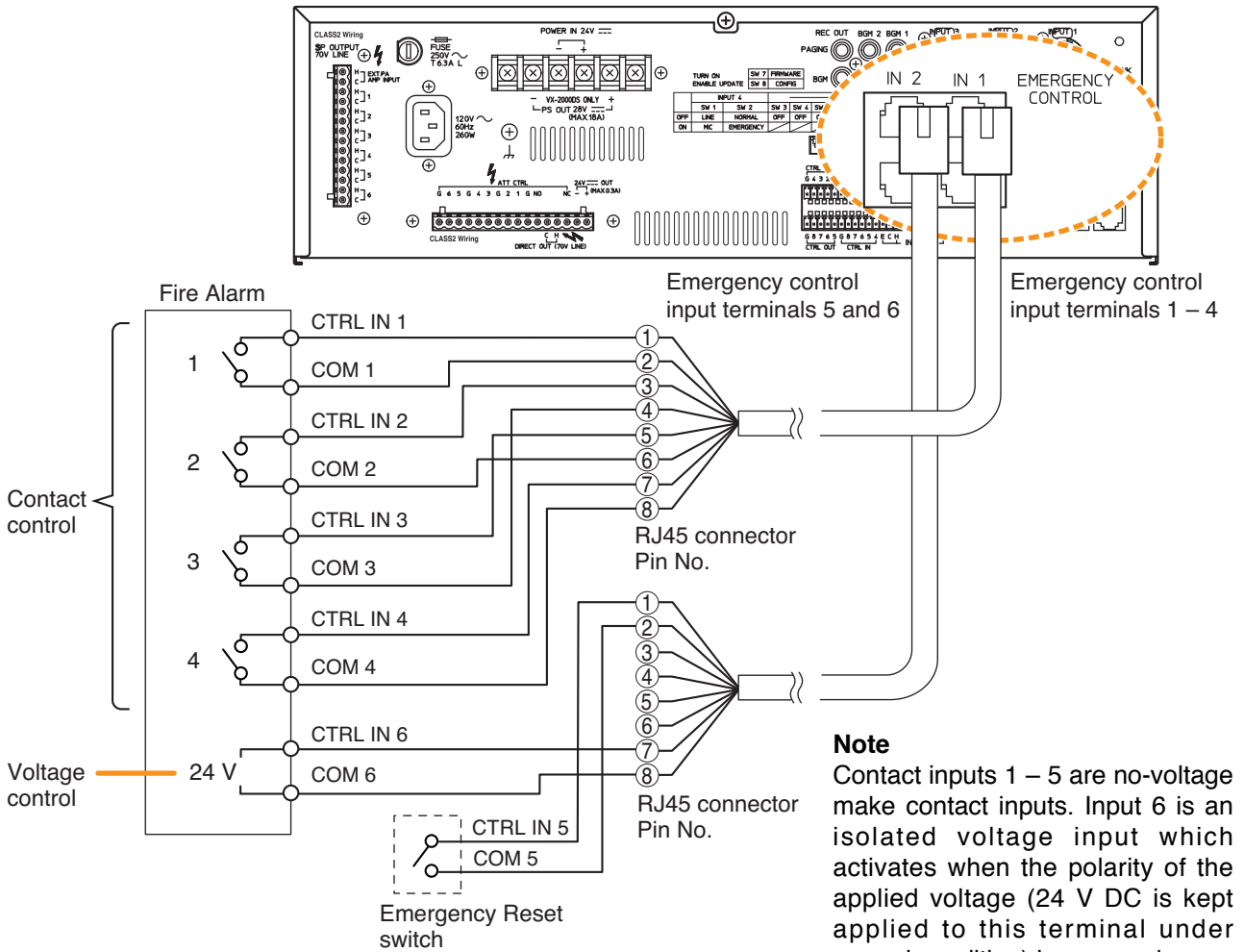

[Terminal assignment to the emergency control inputs]

Connector name	RJ45 connector pin No.	Cable color (T568B type)	Cable color (T568A type)	Pair	Assignment
CTRL IN 1 – 4	①	Orange/White	Green/White	[Orange-White] [Green-White]	CTRL IN 1
	②	Orange	Green		COM 1
	③	Green/White	Orange/White	[Green-White] [Orange-White]	CTRL IN 2
	④	Blue	Blue		COM 3
	⑤	Blue/White	Blue/White	[Blue-White] [Blue-White]	CTRL IN 3
	⑥	Green	Orange		COM 2
	⑦	Brown/White	Brown/White	[Brown-White] [Brown-White]	CTRL IN 4
	⑧	Brown	Brown		COM 4
	Shield	—	—		NC
CTRL IN 5 – 6	①	Orange/White	Green/White	[Orange-White] [Green-White]	CTRL IN 5
	②	Orange	Green		COM 5
	③	Green/White	Orange/White	[Green-White] [Orange-White]	Not used
	④	Blue	Blue		Not used
	⑤	Blue/White	Blue/White	[Blue-White] [Blue-White]	Not used
	⑥	Green	Orange		Not used
	⑦	Brown/White	Brown/White	[Brown-White] [Brown-White]	CTRL IN 6
	⑧	Brown	Brown		COM 6
	Shield	—	—		NC

14.5.2. Using the Amplifier cut off function

This connection allows broadcast from an external broadcast system to override the broadcast currently in progress within the VM-3000 system by cutting off the VM-3000 system's built-in amplifier. Connect the amplifier output and announcement start contact output of the external broadcast system to the EXT. PA AMP INPUT and Emergency control input terminals of the VM amplifier, respectively.

The figure below shows an example to set this function to the Emergency control input 1.

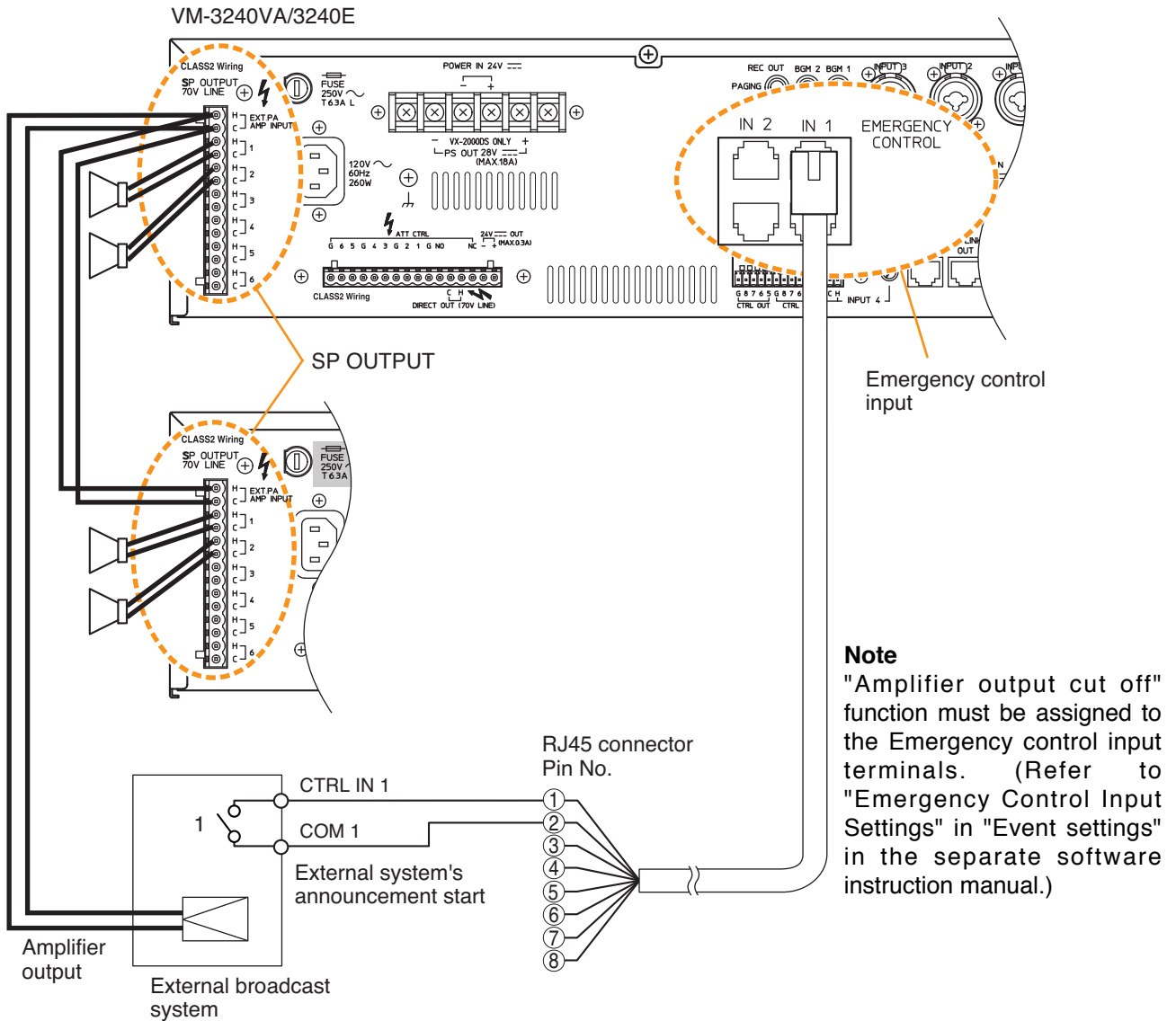

Tip

Use a cable fitted with RJ45 connectors for connection to the Emergency control input terminal. Shown above gives an example of Pin arrangement. (Refer to ["Terminal assignment to the emergency control inputs"](#) on page 121.)

14.5.3. Connections to detect failures on the emergency control input lines

Two types of control methods are available for the Emergency control input in the VM-3000 system: Contact control input (Emergency control input terminals 1 – 5) and Voltage control input (Emergency control input terminal 6).

Failures on each control input line can be detected in the following connections.

The control input terminals to be surveyed should be set by the setting software. (Refer to "Surveillance Settings" in the separate software manual.)

* For the surveillance function, refer to [page 49](#).

[Contact control input terminals (EMERGENCY CONTROL 1 – 5)]

Receive emergency control output (contact output) from external equipment, then activate an emergency broadcast.

Connect the lines to be surveyed as shown below.

VM-3240VA rear

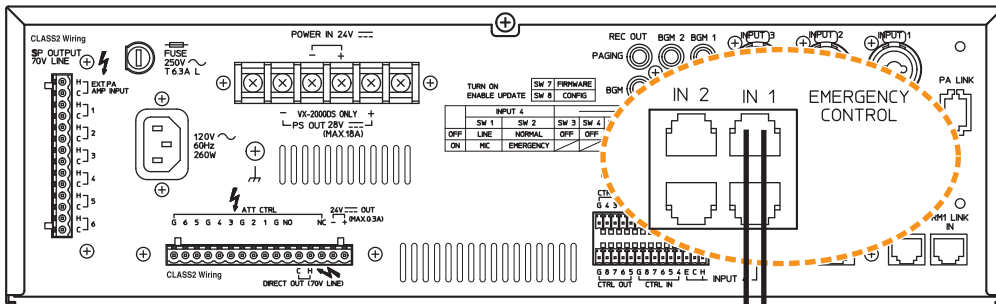

Emergency control input terminals 1 to 5

Control output terminals of the external device (Fire alarm or other control equipment)

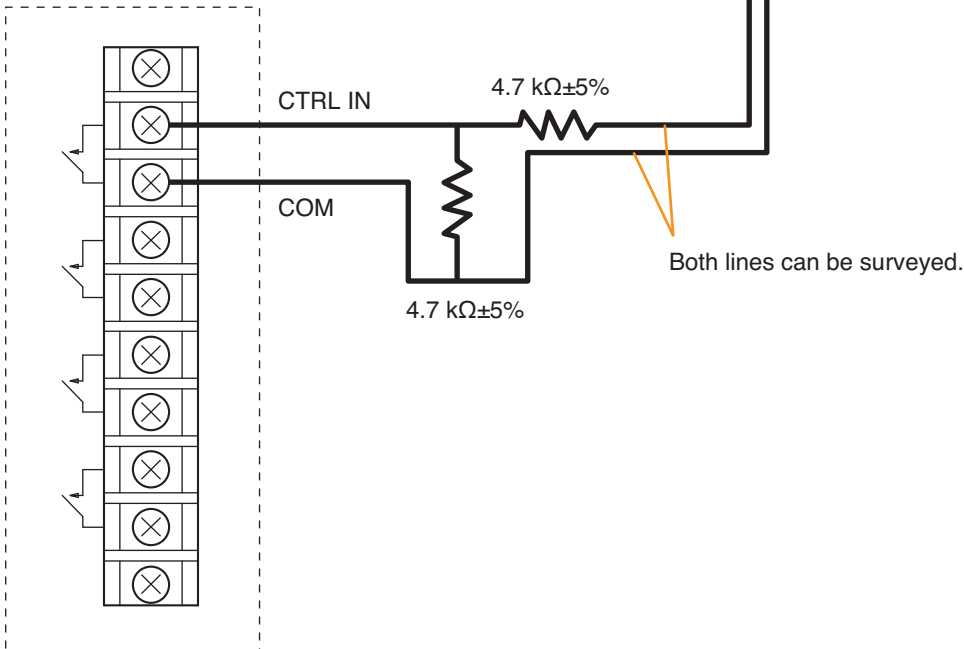

[Voltage control input terminal (EMERGENCY CONTROL 6)]

24 V DC is kept applied to the COM terminal under normal condition. Reversing this applied voltage polarity activates an emergency broadcast.

The surveillance function judges the line normal when 24 V DC is detected at the COM terminal under normal condition and when 24 V DC is detected at the emergency control input terminal 6 under emergency condition.

It judges the line open if no voltage is detected under any condition.

The figures below show the line surveillance methods under normal and emergency conditions.

How the surveillance function works under normal condition

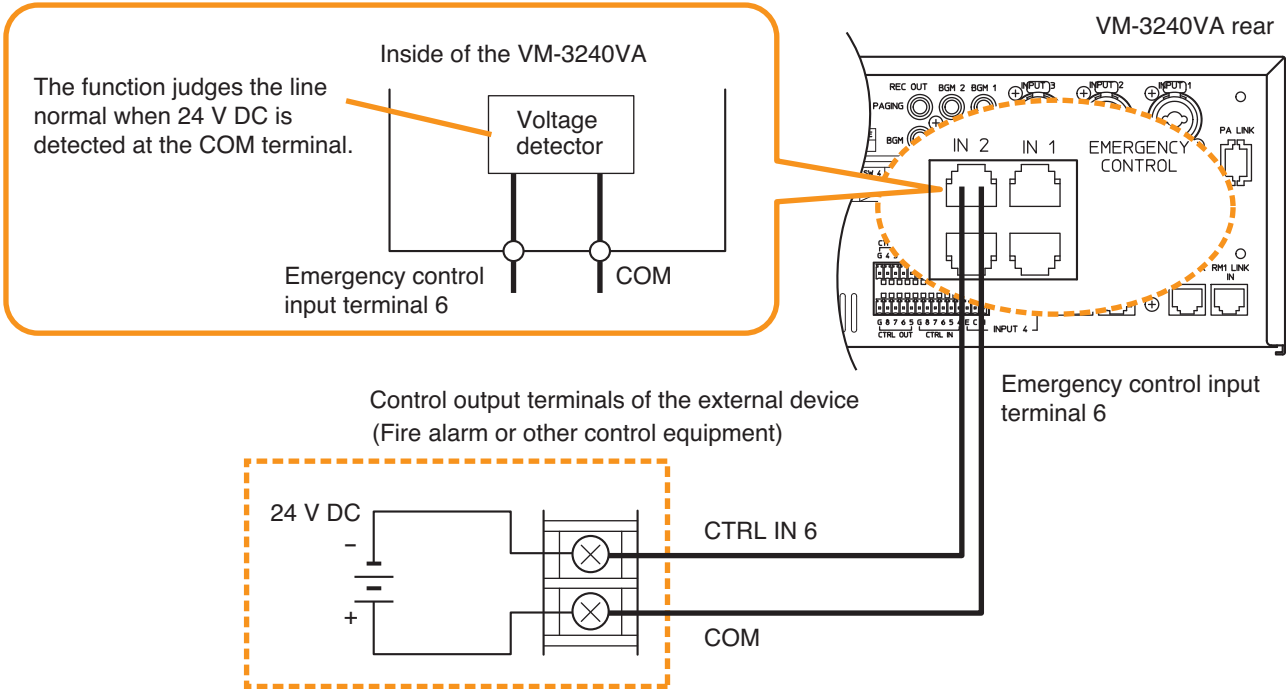

How the surveillance function works under emergency condition

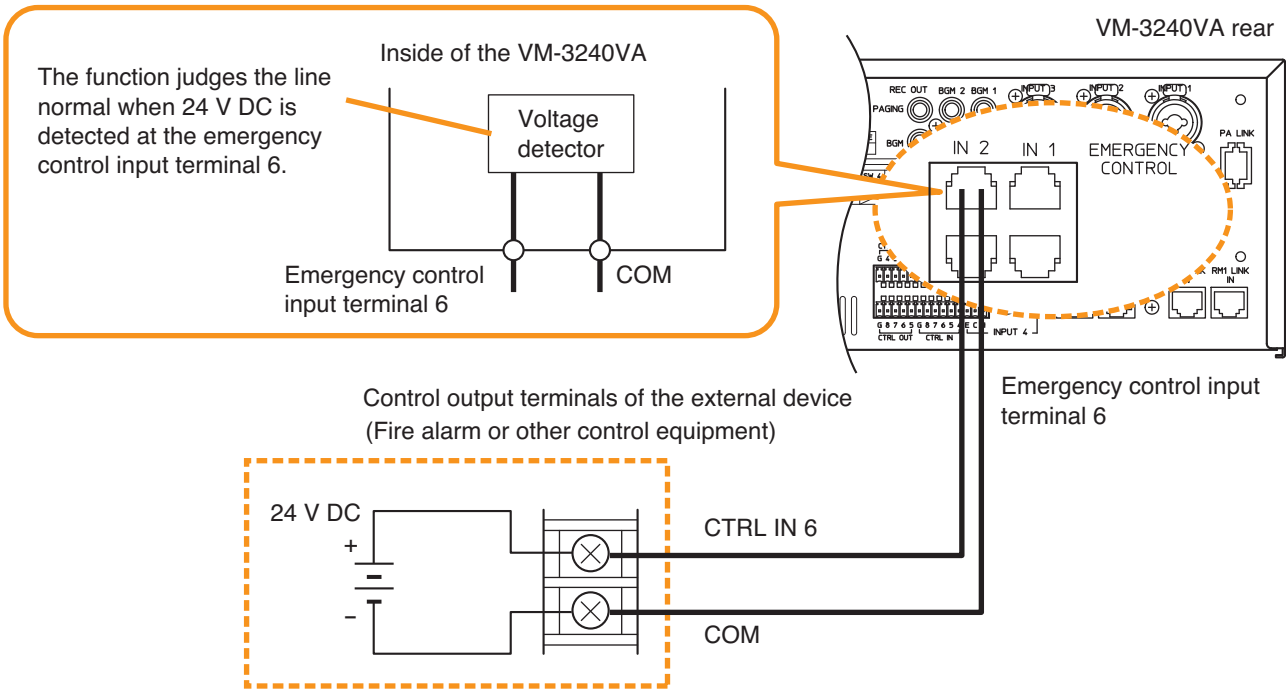

14.6. Status Output Terminal Connections

These terminals provide control outputs of relay contact type.
Control signals (make contact) are output in synchronization with unit operation.

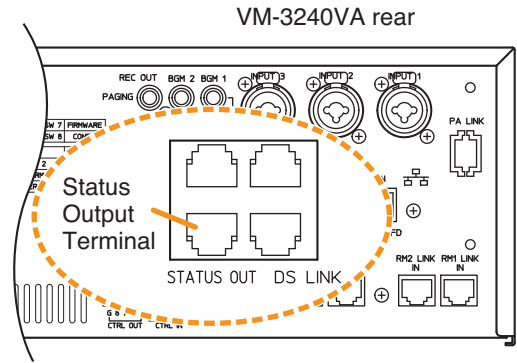

The RJ45's pin arrangement and pin functions are shown below.

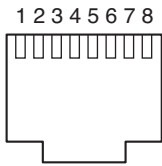

Pin 1	Pin 2	Pin 3	Pin 4	Pin 5	Pin 6	Pin 7	Pin 8
CPU OFF STATUS OUT		FAULT STATUS OUT			EMERGENCY STATUS OUT		
COM	NO*1	COM	NO*1	NC*2	COM	NO*1	NC*2

*1 NO: Normally Open
*2 NC: Normally Closed

[Operation at CPU OFF status output]

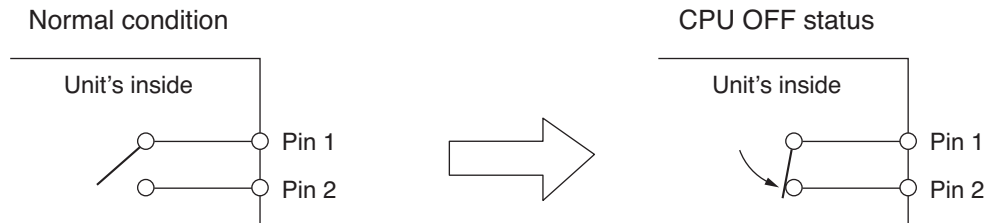

[Operation at failure status output]

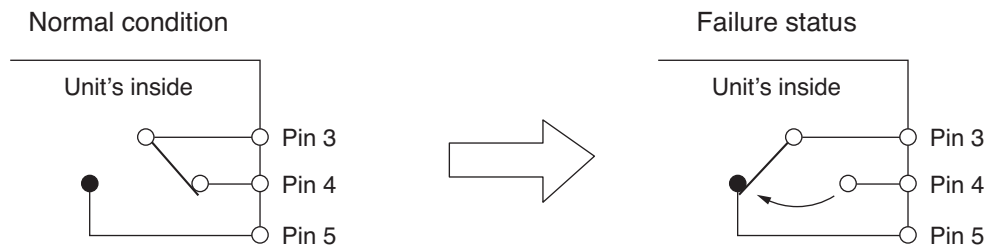

[Operation at emergency status output]

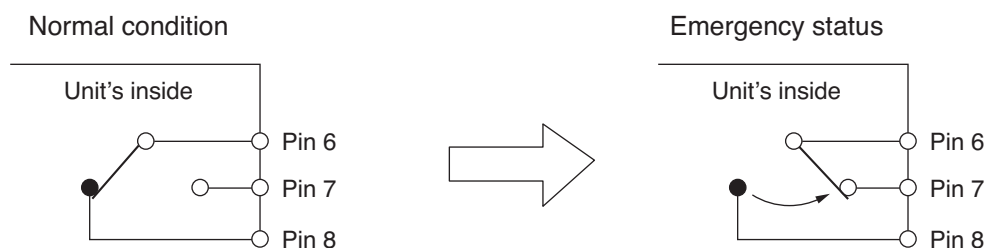

14.7. Power Amplifier and Speaker Connections

14.7.1. Speaker connection

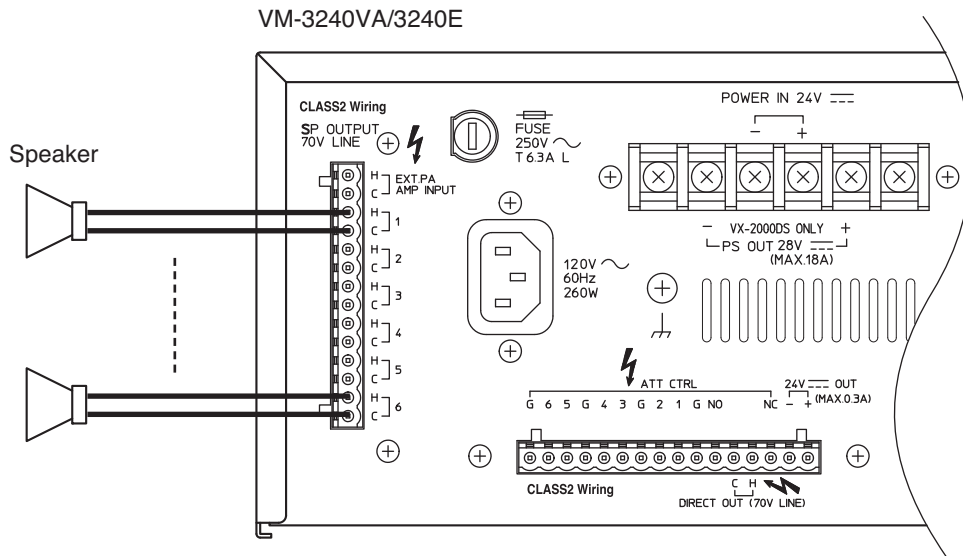

14.7.2. External attenuator connection (3-wire system)

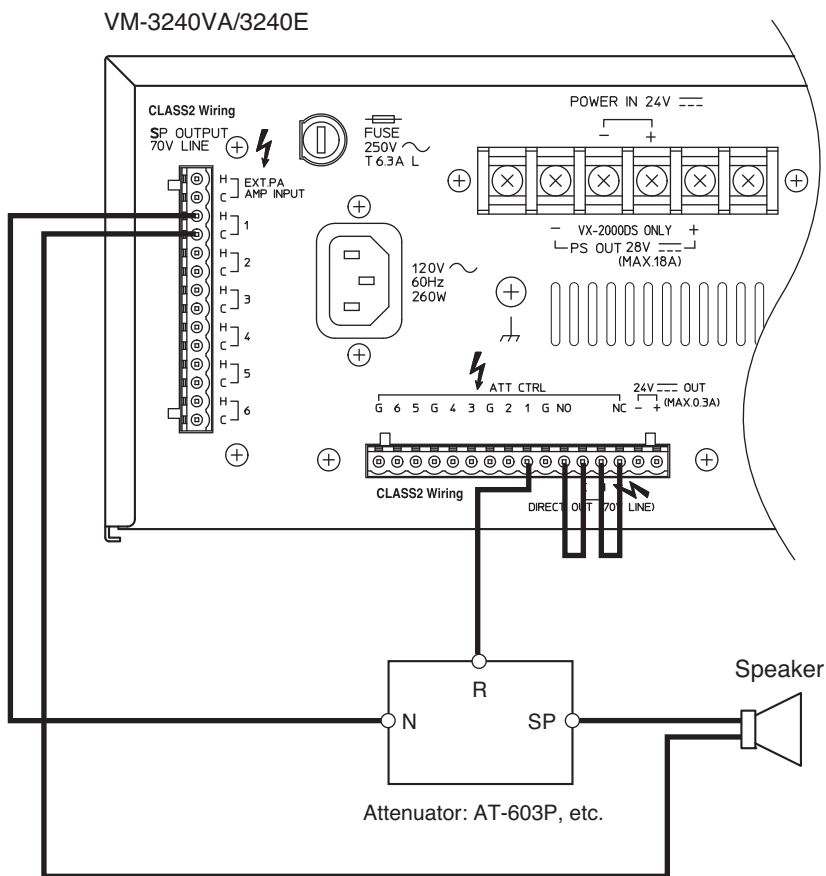

Note

When initializing the surveillance settings, the total speaker wattage per line should be 20 W (500 Ω) or more. Lighter speaker load may cause false detection.

14.7.3. External attenuator connection (4-wire system)

Two types of attenuators are connectable to this unit, one to be bypassed when 24 V DC is applied to the attenuator, and the other to be bypassed when the 24 V DC being normally applied to is cut off (in no voltage mode). Connections of the unit's attenuator control output and 24 V DC output terminals differ depending on the attenuator types as shown below.

[Example 1]

Operation status of the VM amplifier and the corresponding attenuator operation

Operation status of VM amplifier	Applied voltage to the attenuator	Attenuator operation
Normal mode	No-voltage	Normal operation
At the time of emergency broadcast, or Priority 1 or 2 broadcast	24 V DC	Bypassed

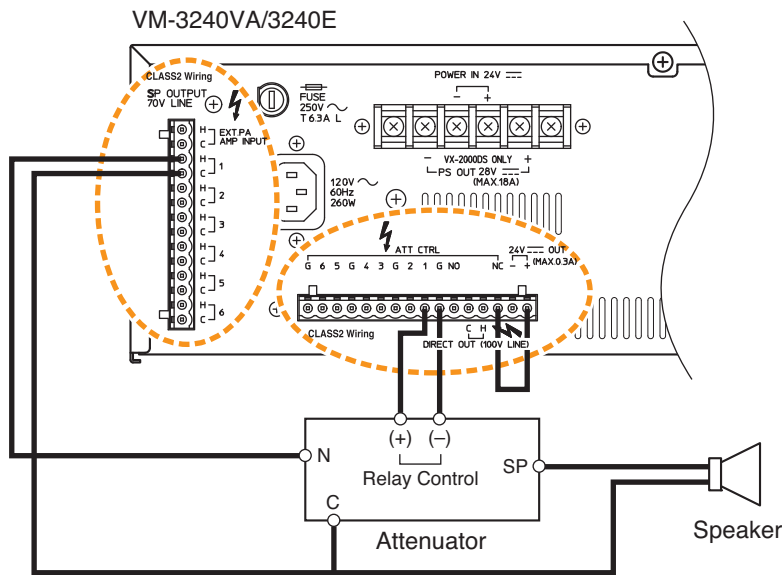

[Example 2]

Operation status of the VM amplifier and the corresponding attenuator operation

Operation status of VM amplifier	Applied voltage to the attenuator	Attenuator operation
Normal mode	24 V DC	Normal operation
At the time of emergency broadcast, or Priority 1 or 2 broadcast	No-voltage	Bypassed

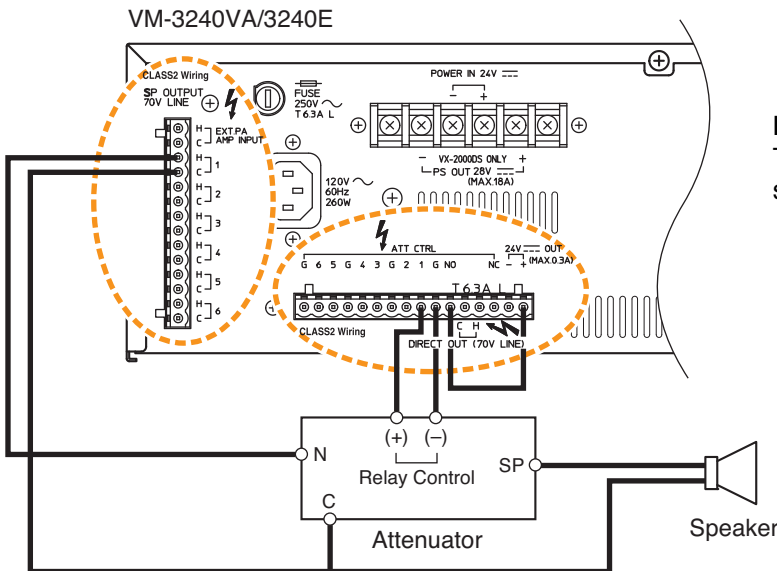

Note
The system in Example 2 is more fail-safe than that in Example 1.

14.8. Connections between VM and VP Amplifiers

[Connection example: System including a standby amplifier]

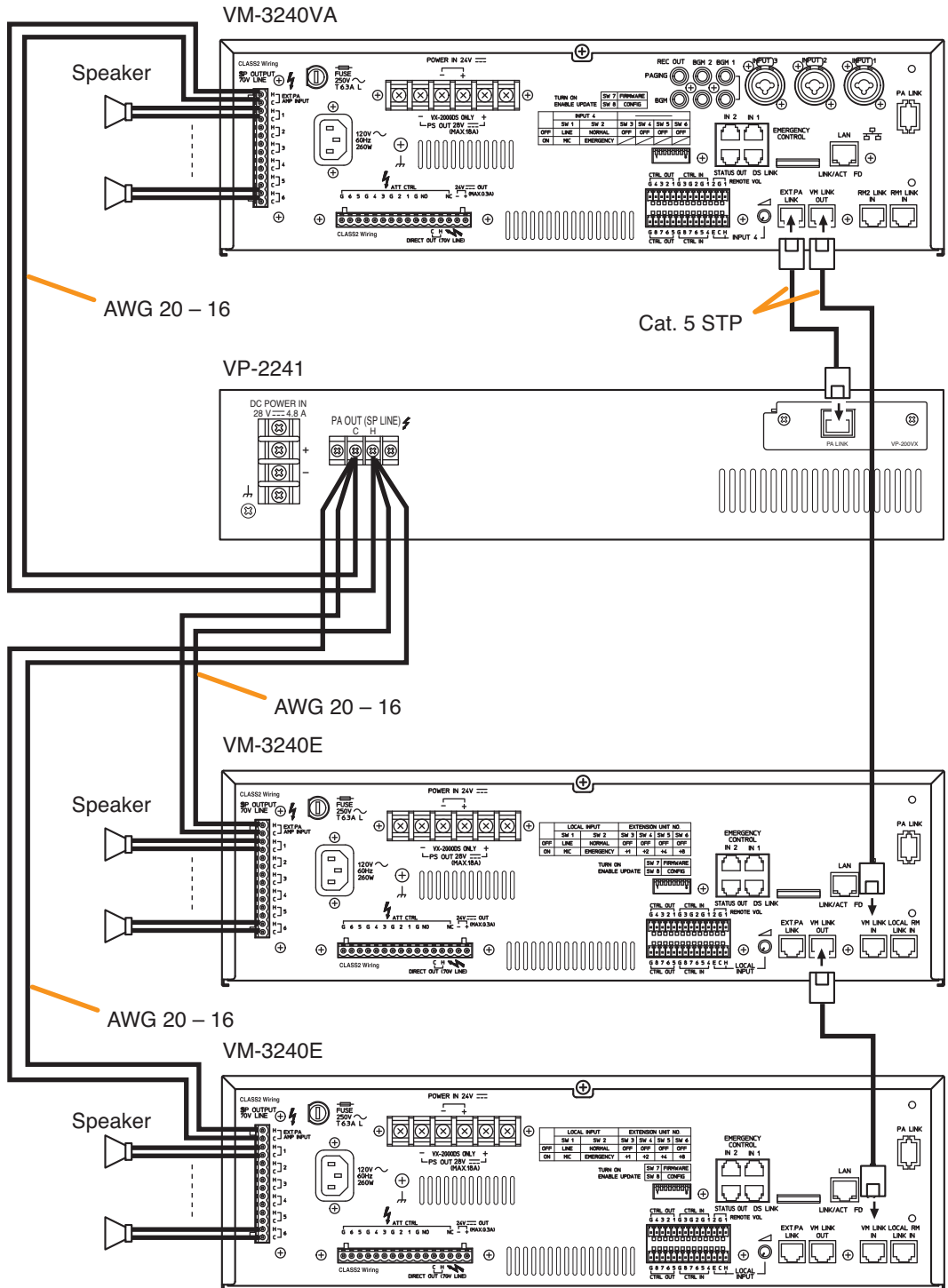

□ --- RJ45 male connector

[Connection example: BGM/Paging system]

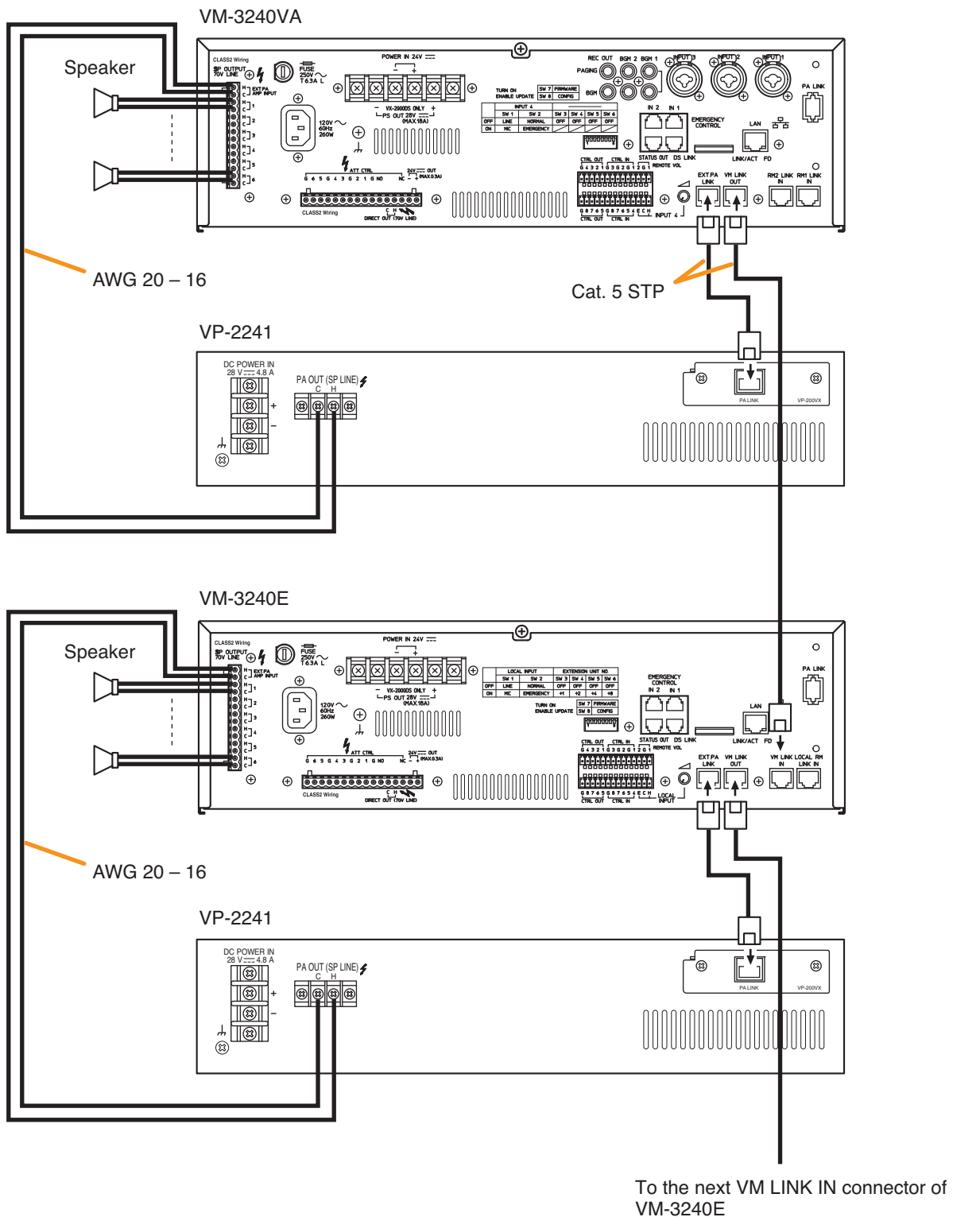

--- RJ45 male connector

14.9. Connections between VM Amplifiers

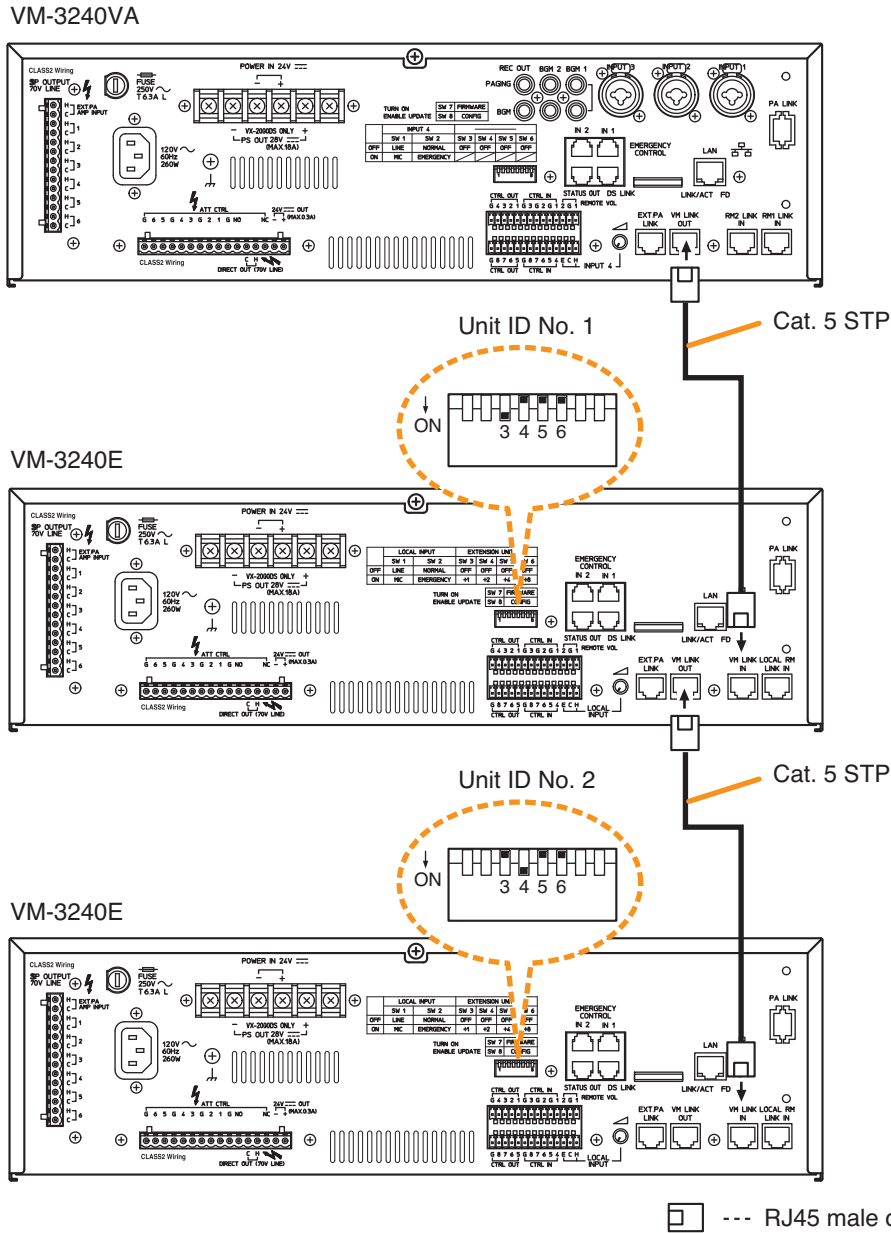

Notes

- When connecting 2 VM-3240E units or more in a system, set the Unit ID with the DIP switch located on each unit's rear panel. Make individual Unit ID numbers different because duplicating ID numbers causes unit malfunction.
- When the Unit ID of VM-3240E has been changed while the system power is on, be sure to restart the system by pushing the front-mounted reset switch on the VM-3240VA.

ID No.	DIP switch	SW 3 (+1)	SW 4 (+2)	SW 5 (+4)	SW 6 (+8)	ID No.	DIP switch	SW 3 (+1)	SW 4 (+2)	SW 5 (+4)	SW 6 (+8)
ID No. 1		ON	OFF	OFF	OFF	ID No. 6		OFF	ON	ON	OFF
ID No. 2		OFF	ON	OFF	OFF	ID No. 7		ON	ON	ON	OFF
ID No. 3		ON	ON	OFF	OFF	ID No. 8		OFF	OFF	OFF	ON
ID No. 4		OFF	OFF	ON	OFF	ID No. 9		ON	OFF	OFF	ON
ID No. 5		ON	OFF	ON	OFF						

Note
SW 3 – 6 are DIP switch numbers.

14.10. Connecting Power Supply Equipment

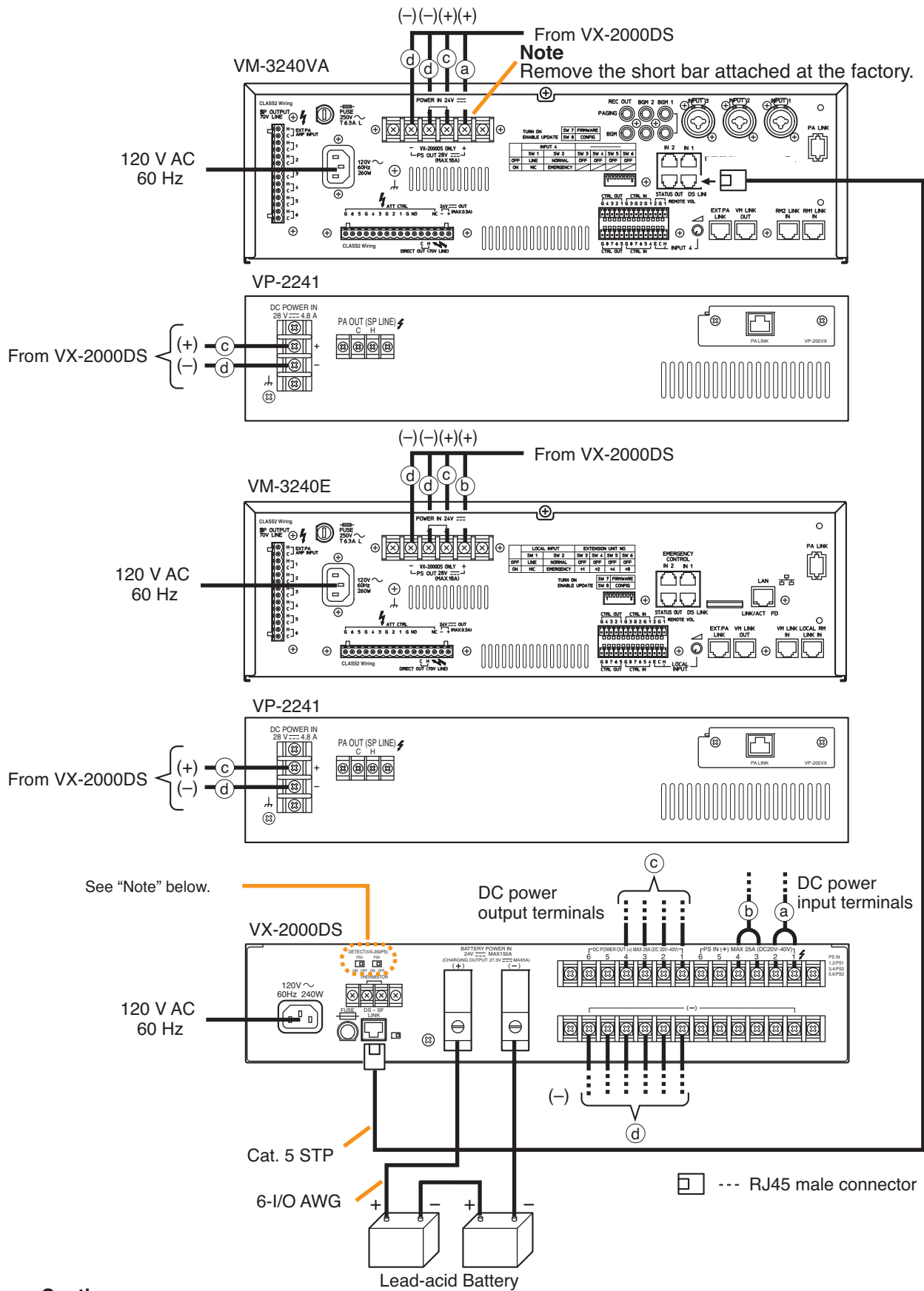

Caution

The charging current from the VX-2000DS is 5 A maximum.

Note

Make PS2 and PS3 switch settings according to the total number of connected power supply units VM-3240VA and VM-3240E (power supply unit incorporated); set PS2 to ON for 2 units, and PS2 and PS3 to ON for 3 units.

Note that these power supply units should be connected to the PS IN (+) terminals 1 and 2 for the 1st unit, 3 and 4 for the 2nd unit, and 5 and 6 for the 3rd unit.

[Required number of VX-2000DS units]

The required number of VX-2000DS Emergency Power Supply units is determined depending on the application of the system configured with the VM-3240VA and VM-3240E (hereinafter called "VM amplifier"), and/or the VP-2241 (hereinafter called "VP amplifier").

• Required number in a 1-channel broadcasting system

System including VM amplifiers only

One VX-2000DS is required every 3 VM amplifiers.

Number of VM amplifiers	1	2	3	4	5	6	7	8	9	10
Number of VX-2000DS'	1			2			3			4

Below is an example showing that one VX-2000DS is required in a system including 3 VM amplifiers.

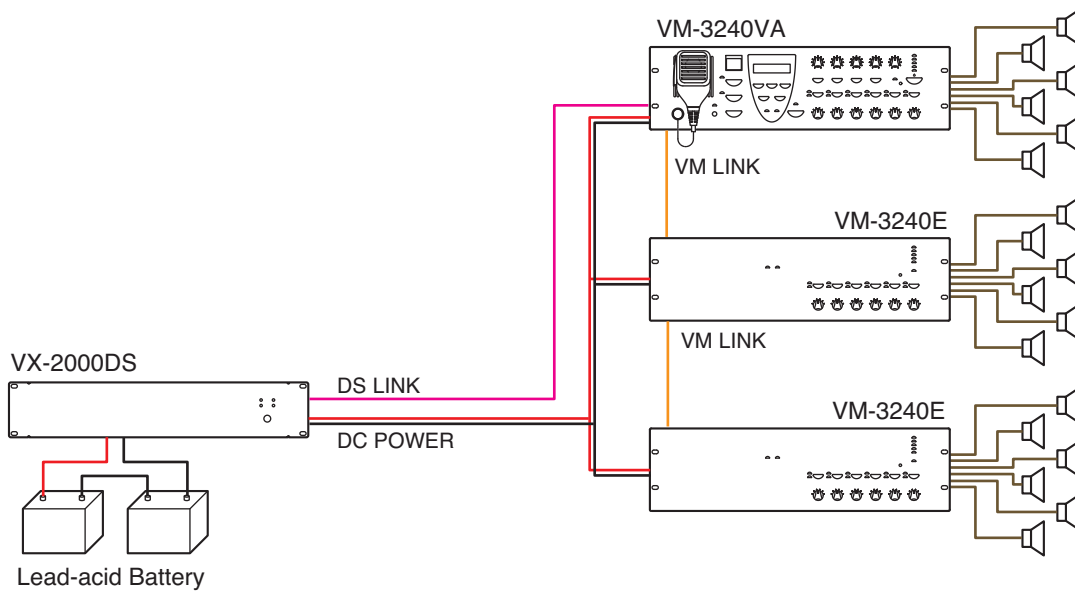

System including one VP amplifier connected as a standby amplifier

One VX-2000DS is required every 3 VM amplifiers.

Number of VM amplifiers	1	2	3	4	5	6	7	8	9	10
Number of VX-2000DS'	1			2			3			4
Maximum output of each VM amplifier	240 W			160 W						

The maximum output of each amplifier is 160 W, if 4 or more VM amplifiers are connected.

Below is an example showing that 2 VX-2000DSs are required in a system including 4 VM amplifiers.

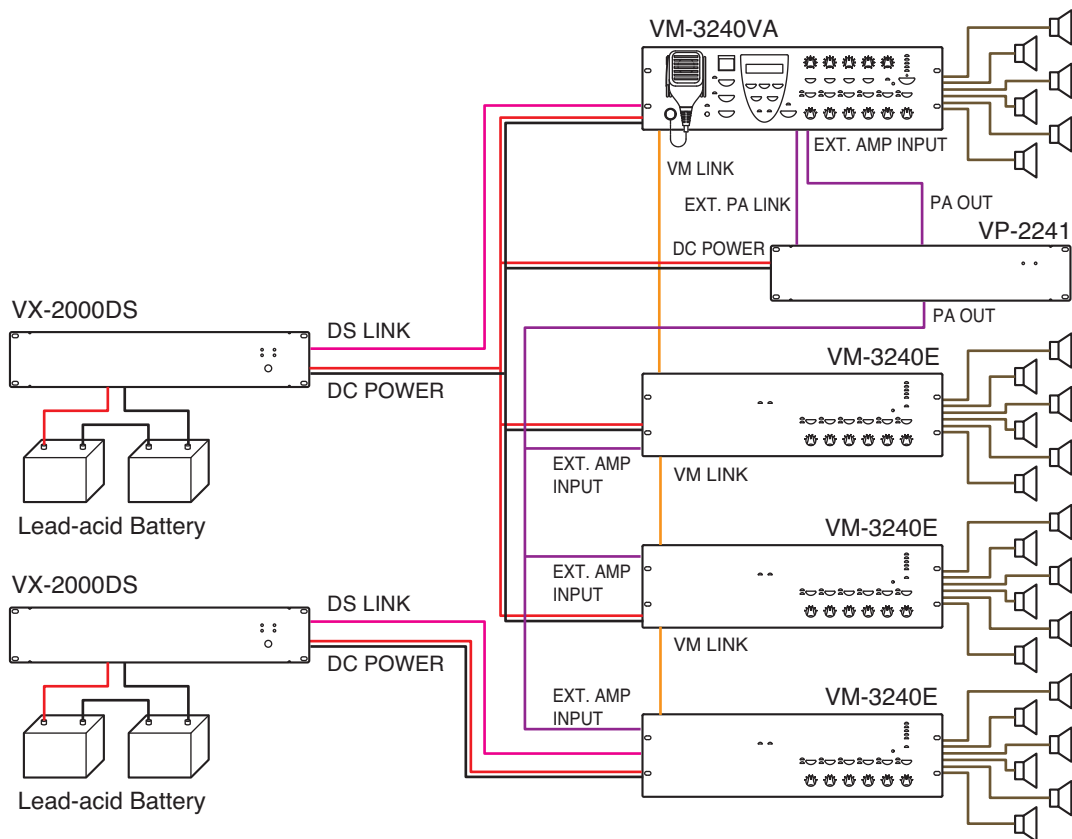

• **Required number in a BGM/Paging system**

One VX-2000DS is required every 3 VM amplifiers.

Number of VM amplifiers	1	2	3	4	5	6	7	8	9	10
Number of VX-2000DS'	1			2			3			4
Maximum output of each VM amplifiers	200 W									

In BGM/Paging system mode, the maximum output of each VM amplifier is 200 W.

Below is an example showing that 2 VX-2000DSs are required in a system including 4 VM amplifiers.

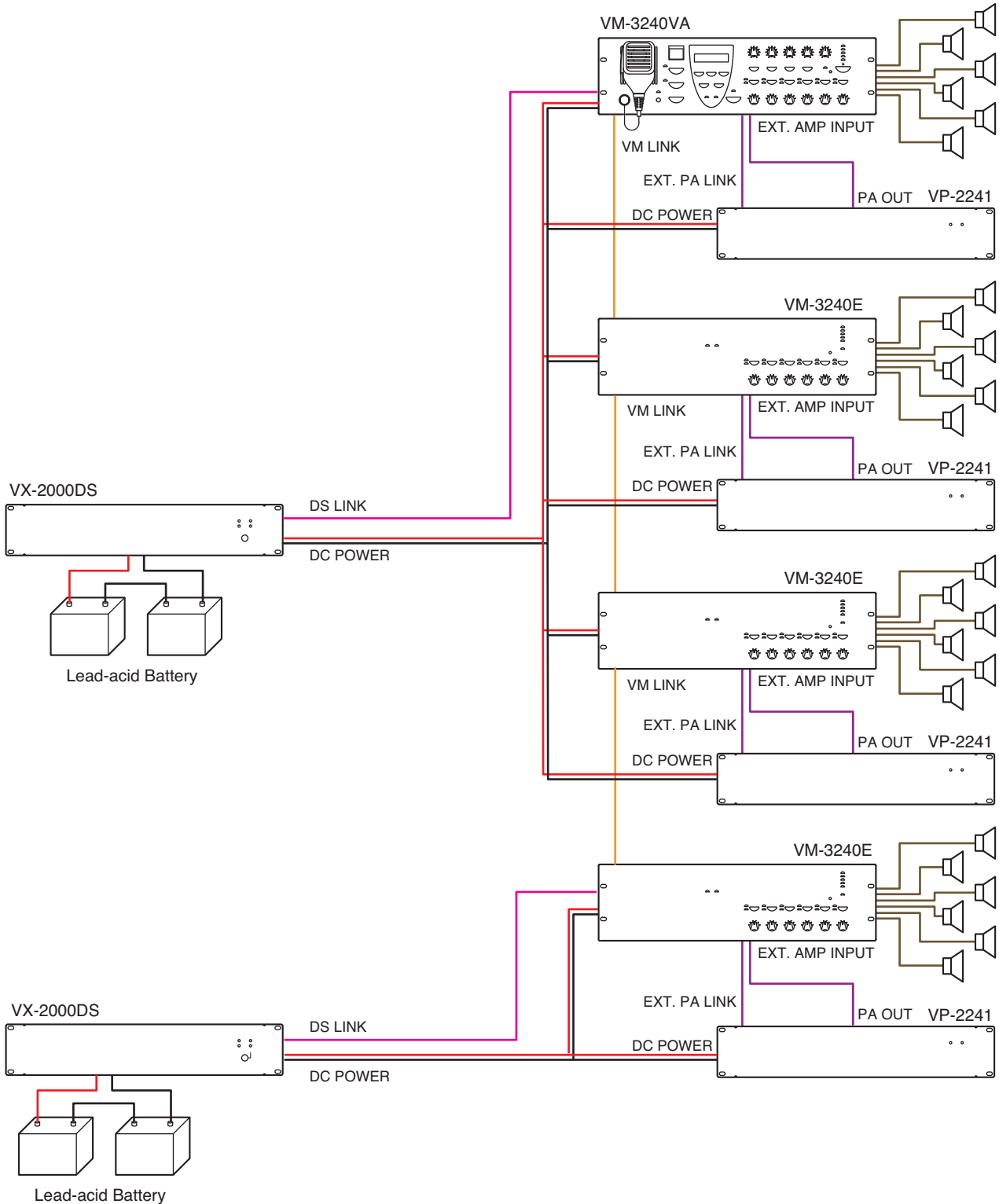

Note

A pair of the VM amplifier and VP amplifier should be connected to the same VX-2000DS.

15. VM-3000 CABLE USAGE TABLE

This table shows the cables to be used in the VM-3000 and their connection locations.

[VM-3240VA]

Terminal to Connect		Cable Type			Equipment to be Connected to		
Terminal Name	Equipment Receptacle	Plug	Cable Type	Plug	Equipment Receptacle	Terminal Name	Equipment
AC IN	3P inlet	AC plug	Supplied cable	AC plug	AC OUTLET AC 230 V, 50/60 Hz		
POWER IN 24 V	Screw terminal	Round terminal	10 – 8 AWG	Round terminal	Screw terminal	DC POWER OUT	VX-2000DS
PS OUT	Screw terminal	Round terminal	10 – 8 AWG	Round terminal	Screw terminal	PS IN	VX-2000DS
CTRL OUT	Screw terminal block	Unprocessed cable end	28 – 22 AWG	—	—	—	Other control unit
CTRL IN	Screw terminal block	Unprocessed cable end	28 – 22 AWG	—	—	—	Other control unit
EXT. PA LINK	RJ45 (female)	RJ45 (male)	Cat. 5 STP	RJ45 (male)	RJ45 (female)	PA LINK (VP-200VX)	VP-2241
VM LINK OUT	RJ45 (female)	RJ45 (male)	Cat. 5 STP	RJ45 (male)	RJ45 (female)	VM LINK IN	VM-3240E
EMERGENCY CONTROL IN	RJ45 (female)	RJ45 (male)	Cat. 5 STP	—	—	—	Fire alarm system/Other control unit
DS LINK	RJ45 (female)	RJ45 (male)	Cat. 5 STP	RJ45 (male)	RJ45 (female)	DS SF LINK	VX-2000DS
STATUS OUT	RJ45 (female)	RJ45 (male)	Cat. 5 STP	—	—	—	Other unit
LAN	RJ45 (female)	RJ45 (male)	Cat. 5 STP	RJ45 (male)	RJ45 (female)	—	HUB
RM LINK IN	RJ45 (female)	RJ45 (male)	Cat. 5 STP	Unprocessed cable end	Screw terminal	DC IN/DATA /AUDIO OUT/ SHIELD	RM-300MF (Wall mount bracket unit)
				RJ45 (male)	RJ45 (female)	LINK	RM-200M

[VM-3240E]

Terminal to Connect		Cable Type			Equipment to be Connected to		
Terminal Name	Equipment Receptacle	Plug	Cable Type	Plug	Equipment Receptacle	Terminal Name	Equipment
AC IN	3P inlet	AC plug	Supplied cable	AC plug	AC OUTLET AC 230 V, 50/60 Hz		
POWER IN 24 V	Screw terminal	Round terminal	10 – 8 AWG	Round terminal	Screw terminal	DC POWER OUT	VX-2000DS
PS OUT	Screw terminal	Round terminal	10 – 8 AWG	Round terminal	Screw terminal	PS IN	VX-2000DS
CTRL OUT	Screw terminal block	Unprocessed cable end	28 – 22 AWG	—	—	—	Other control unit
CTRL IN	Screw terminal block	Unprocessed cable end	28 – 22 AWG	—	—	—	Other control unit
EXT. PA LINK	RJ45 (female)	RJ45 (male)	Cat. 5 STP	RJ45 (male)	RJ45 (female)	PA LINK (VP-200VX)	VP-2241
VM LINK OUT	RJ45 (female)	RJ45 (male)	Cat. 5 STP	RJ45 (male)	RJ45 (female)	VM LINK IN	VM-3240E
VM LINK IN	RJ45 (female)	RJ45 (male)	Cat. 5 STP	RJ45 (male)	RJ45 (female)	VM LINK OUT	VM-3240VA /3240E
EMERGENCY CONTROL IN	RJ45 (female)	RJ45 (male)	Cat. 5 STP	—	—	—	Fire alarm system/Other control unit
DS LINK	RJ45 (female)	RJ45 (male)	Cat. 5 STP	RJ45 (male)	RJ45 (female)	DS SF LINK	VX-2000DS
STATUS OUT	RJ45 (female)	RJ45 (male)	Cat. 5 STP	—	—	—	Other unit

[VP-2241]

Terminal to Connect		Cable Type			Equipment to be Connected to		
Terminal Name	Equipment Receptacle	Plug	Cable Type	Plug	Equipment Receptacle	Terminal Name	Equipment
PA OUT (SP LINE)	2P screw terminal	Round or Y terminal	20 – 16 AWG	Round or Y terminal	Screw terminal	EXT. PA AMP INPUT	VM-3240VA /3240E
DC POWER IN	2P screw terminal	Round terminal	10 – 8 AWG	Round terminal	Screw terminal	DC POWER OUT	VX-2000DS
PA LINK (VP-200VX)	RJ45 (female)	RJ45 (male)	Cat. 5 STP	RJ45 (male)	RJ45 (female)	EXT. PA LINK	VM-3240VA /3240E

[VX-2000DS]

Terminal to Connect		Cable Type			Equipment to be Connected to		
Terminal Name	Equipment Receptacle	Plug	Cable Type	Plug	Equipment Receptacle	Terminal Name	Equipment
AC IN	3P inlet	AC plug	Supplied cable	AC plug	AC OUTLET AC 230 V, 50/60 Hz		
DS-SF LINK	RJ45 (female)	RJ45 (male)	Cat. 5 STP	RJ45 (male)	RJ45 (female)	DS LINK	VM-3240VA /3240E
BATTERY POWER IN	Screw terminal	Unprocessed cable end	6-1/0AWG	Unprocessed cable end	Electrode (+,-)		Lead-acid battery
DC POWER OUT	Screw terminal	Round terminal	10 – 8 AWG	Round terminal	2P screw terminal	DC POWER IN	VM-3240VA /3240E
			12 – 24 AWG	Round or Y terminal	Screw terminal	DC IN 24 V	RM-300MF

16. SPECIFICATIONS

16.1. VM-3240VA Voice Alarm System Amplifier

Power Source	120 V AC, 60 Hz
Power Consumption	600 W (at rated output), 260 W (according to UL60065)
Rated Output	240 W (21 Ω , total of Speaker output 1 – 6 and Direct output)
Frequency Response	50 Hz – 20 kHz, ± 3 dB (at 1/3 rated output)
Distortion	0.7% or less (at rated output, 1 kHz)
S/N Ratio	85 dB or more
Audio Input/Output Characteristic	Sampling frequency: 48 kHz A/D D/A converter: 24 bit
Input	Input 1 – 3: –50 dB* (MIC) / –10 dB* (LINE) (changeable), 600 Ω , electronically balanced, combined XLR connector (female) / phone jack Input 4: –50 dB* (MIC) / –10 dB* (LINE) (changeable), 600 Ω , electronically balanced, removable terminal block (14 pins) BGM 1 – 2: –10 dB*, 10 k Ω , unbalanced, RCA pin jack External AMP Input: 70 V line, removable terminal block (14 pins)
Output	Speaker output 1 – 2: Max. (240 W) per output Speaker output 3 – 6: Max. (120 W) per output Speaker output 1 – 6: Total within 240 W, removable terminal block (14 pins) Allowable minimum load: 245 Ω (20 W) at 70 V line for speaker line failure detection Direct output: Direct output from internal or external amplifier, removable terminal block (16 pins) Recording output BGM/Paging: 0 dB*, 10 k Ω , unbalanced, RCA pin jack
RM Link	Input 1 – 2: Connecting the RM-300MF/200M Remote Microphone, RJ45 female connector Maximum distance: Total 800 m between this unit and remote microphones Link cable: Category 5 Shielded Twisted-Pair straight cable (CAT5-STP)
Network I/F	10BASE-T/100BASE-TX (selectable by automatic negotiation), RJ45 female connector Maximum distance: 100 m between this unit and a switching hub Link cable: Category 5 Shielded Twisted-Pair straight cable (CAT5-STP)
VM Link	Output: Connecting the VM-3240E, RJ45 female connector Maximum distance: Total 800 m Link cable: Category 5 Shielded Twisted-Pair straight cable (CAT5-STP)
EXT PA Link	Connecting the VP-2241, RJ45 female connector Maximum distance: 5 m Link cable: Category 5 Shielded Twisted-Pair straight cable (CAT5-STP)
General Control	Input 1 – 8: No-Voltage make contact input, open voltage: 24 V DC, short-circuit current: 2 mA or less, removable terminal block (14 pins) Output 1 – 8: Isolated open collector output, withstand voltage: 30 V DC, operating current: 10 mA or less, removable terminal block (14 pins)
Emergency Control	Input 1 – 5: No-Voltage make contact input, open voltage: 24 V DC, short-circuit current: 2 mA or less, RJ45 female connector Input 6: Isolated voltage input, Inactive: –24 V $\pm 20\%$, Active: +24 V $\pm 20\%$, RJ45 female connector Status out: Relay contact output, withstand voltage: 40 V DC, operating current: 2 – 300 mA, RJ45 female connector
ATT Control	Relay contact 1 – 6, 125 V AC or 30 V DC, total under 5 A, removable terminal block (16 pins)
Power Input/Output	Power in: Connecting the VX-2000DS only (operating range: 20 – 40 V DC) PS out: 28 V DC / 18 A M4 screw terminal, distance between barriers: 11 mm
24 V DC Output	24 V DC, Maximum feeding current 0.3 A

Ds Link	Connecting the VX-2000DS, RJ45 female connector Maximum distance: 5 m Link cable: Category 5 Shielded Twisted-Pair straight cable (CAT5-STP)
Operating Temperature	0 to +40°C
Operating Humidity	5% to 95% RH (no condensation)
Finish	Panel: Aluminum, hair-line, black Case: Surface-treated steel plate, black, paint
Dimensions	482 (w) x 132.6 (h) x 431.2 (d) mm
Weight	16.5 kg

* 0 dB = 1 V

Note: The design and specifications are subject to change without notice for improvement.

• **Accessories**

AC power cord (2 m)	1
Emergency microphone (hand-held type)	1
Plastic foot	4
Plastic foot mounting screw	4
Removable terminal plug (14 pins)	3
Removable terminal plug (16 pins)	1
Link cable (3 m)	1
Setting software-CD	1

• **Optional product**

Input transformer: IT-450

16.2. VM-3240E VM Extension Amplifier

Power Source	120 V AC, 60 Hz
Power Consumption	600 W (at rated output), 260 W (according to UL60065)
Rated Output	240 W (21 Ω, total of Speaker output 1 – 6 and Direct output)
Frequency Response	50 Hz – 20 kHz, ±3 dB (at 1/3 rated output)
Distortion	0.7% or less (at rated output, 1 kHz)
S/N Ratio	85 dB or more
Input	External amplifier Input: 70 V line, removable terminal block (14 pins) Local Input: –50 dB* (MIC) / –10 dB* (LINE) (changeable), 600 Ω, electronically balanced, removable terminal block (14 pins)
Output	Speaker output 1 – 2: Max. (240 W) per output Speaker output 3 – 6: Max. (120 W) per output Speaker output 1 – 6: Total within 240 W, removable terminal block (14 pins) Allowable minimum load: 245 Ω (20 W) at 70 V line for speaker line failure detection Direct output: Direct output from internal or external amplifier, removable terminal block (16 pins)
VM Link	Input: Connecting the VM-3240VA RJ45 female connector Output: Connecting the VM-3240E RJ45 female connector Maximum distance: 800 m Link cable: Category 5 Shielded Twisted-Pair straight cable (CAT5-STP)
EXT PA Link	Connecting the VP-2241, RJ45 female connector Maximum distance: 5 m Link cable: Category 5 Shielded Twisted-Pair straight cable (CAT5-STP)
General Control	Input 1 – 8: No-Voltage make contact input, open voltage: 24 V DC, short-circuit current: 2 mA or less, removable terminal block (14 pins) Output 1 – 8: Isolated open collector output, withstand voltage: 30 V DC, operating current: 10 mA or less, removable terminal block (14 pins)
Emergency Control	Input 1 – 5: No-Voltage make contact input, open voltage: 24 V DC, short-circuit current: 2 mA or less, RJ45 female connector Input 6: Isolated voltage input, Inactive: –24 V ±20%, Active: +24 V ±20%, RJ45 female connector Status out: Relay contact output, withstand voltage: 40 V DC, operating current: 2 – 300 mA, RJ45 female connector
ATT Control	Relay contact 1 – 6, 125 V AC or 30 V DC, total under 5 A, removable terminal block (16 pins)
Power Input/Output	Power in: Connecting the VX-2000DS only (operating range: 20 – 40 V DC) PS out: 28 V DC / 18 A M4 screw terminal, distance between barriers: 11 mm
24 V DC Output	24 V DC, Maximum feeding current 0.3 A
Ds Link	Connecting the VX-2000DS, RJ45 female connector Maximum distance: 5 m Link cable: Category 5 Shielded Twisted-Pair straight cable (CAT5-STP)
Operating Temperature	0 to +40°C
Operating Humidity	5% to 95% RH (no condensation)
Finish	Panel: Aluminum, hair-line, black Case: Surface-treated steel plate, black, paint
Dimensions	482 (w) x 132.6 (h) x 407 (d) mm
Weight	16.5 kg

Note: The design and specifications are subject to change without notice for improvement.

• Accessories

AC power cord (2 m)	1	Removable terminal plug (14 pins)	3
Plastic foot	4	Removable terminal plug (16 pins)	1
Plastic foot mounting screw	4	Link cable (3 m)	1

16.3. RM-300MF Fireman's Microphone

Power Source	24 V DC (operating range: 15 – 40 V DC, supplied from the VM-3000 system)
Current Consumption	120 mA (RM-300MF), 660 mA (with 3 RM-320Fs connected)
Frequency Response	200 Hz – 15 kHz
Distortion	1% or less
S/N Ratio	55 dB or more
Microphone	Unidirectional dynamic microphone with talk key, compressor (on/off switchable)
Volume Control	Microphone volume control, buzzer volume control
Connection Cable and Terminal	Main line: Shielded CPEV cable (each one pair of Audio line, Data line, Power supply line) or Category 5 Shielded Twisted-Pair straight cable for LAN (CAT5-STP), M3 screw terminal
Maximum Cable Distance	Total 800 m
No. of Connectable RM-320Fs	Max. 3 units
Operation	Emergency key, Evacuate key, Alert key, Emergency reset key, CPU switch, Reset key
Indicator	Power Indicator, Emergency Indicator, Communication Failure Indicator, CPU OFF Indicator, Evacuation Announcement Indicator, Alert Announcement Indicator, Emergency Reset Indicator, Microphone In-Use Indicator, External Emergency Equipment In-Use Indicator
Operating Temperature	–5 to +45°C
Operating Humidity	5% to 95% RH (no condensation)
Finish	ABS resin, blueish gray (PANTONE 538 or its equivalent)
Dimensions	200 (w) x 215 (h) x 82.5 (d) mm
Weight	1.1 kg

Note: The design and specifications are subject to change without notice for improvement.

• **Accessories**

Wall mounting bracket unit	1
Wall mounting screw	2

16.4. RM-320F Fireman's Microphone Extension

Current Consumption	180 mA max. (in terms of RM-300MF)
Connection	Connection to RM-300MF by dedicated cable
Number of Function keys	20
Finish	ABS resin, blueish gray (PANTONE 538 or its equivalent)
Dimensions	175 (w) x 215 (h) x 70 (d) mm
Weight	700 g

Note: The design and specifications are subject to change without notice for improvement.

• **Accessories**

Wall mounting bracket	1
Wall mounting screw	2

16.5. RM-200M Remote Microphone

Power Source	24 V DC (operating range: 14 – 28 V DC) Power input jack: Non-polarity type Usable power input plug*1: Outer diameter ø5.5 mm, inner diameter ø2.1 mm, length 9.5 mm
Current Consumption	100 mA or less
Audio Output	0 dB*2, 600 Ω, balanced
Frequency Response	100 Hz – 20 kHz
Distortion	1% or less
S/N Ratio	60 dB or more
Microphone	Unidirectional electret condenser microphone
Function Key	Number of keys: 10 Function: "Broadcast zone selector" or "Automatic general broadcast Announcement Start" (Either function is assigned to individual keys by the dedicated software.)
Volume Control	Microphone volume control
Connection and Cable Connector	Category 5 Shielded Twisted-Pair straight cable, RJ45 connector
Finish	ABS resin, blueish gray (PANTONE 538 or its equivalent)
Dimensions	190 (w) x 76.5 (h) x 215 (d) mm (Gooseneck microphone excluded)
Weight	750 kg

*1 Use the AC adapter AD-246 or equivalent.

*2 0 dB = 1 V

Note: The design and specifications are subject to change without notice for improvement.

• Accessories

Link cable (3 m) 1

16.6. RM-210 Remote Microphone Extension

Current Consumption	20 mA max. (in terms of RM-200M's DC power input)
Connection	Connection to RM-200M by way of dedicated cable
Number of Function Keys	10
Finish	ABS resin, blueish gray (PANTONE 538 or its equivalent)
Dimensions	110 (w) x 76.5 (h) x 215 (d) mm
Weight	350 g

Note: The design and specifications are subject to change without notice for improvement.

• Accessories

Extension cable 1
Linkage bracket A 1
Linkage bracket B 2
Screw for linkage bracket 2

16.7. VP-2241 Power Amplifier 1 x 240W

Power Source	28 V DC (operating range: 20 – 40 V DC) M4 screw terminal, distance between barriers: 12 mm
Current Consumption (EN60065)	4.8 A
Rated Output Power	240 W (at min. resistive and max. capacitive load)
Output Power (at AC Mains: 195.5 V)	180 W (at min. resistive and max. capacitive load)
Output Voltage	100 V (70 V, 50 V: selectable by internal wiring change)
Minimum Resistive Load	41 Ω (at 100 V), 21 Ω (at 70 V), 10 Ω (at 50 V)
Maximum Capacitive Load	0.5 μF (at 100 V), 1 μF (at 70 V), 1 μF (at 50 V)
Number of Channels	1
Input	Specified by input module VP-200VX
Number of Module Slots	1
Usable Module	VP-200VX
Output	Power amplifier output (speaker line): M3.5 screw terminal, distance between barriers: 8.8 mm
Frequency Response	40 Hz – 16 kHz, ±3 dB (at 1/3 rated output)
Distortion	Under 1% (at rated output, 1 kHz)
Signal-to-Noise Ratio	Over 80 dB
Panel Indicator	Channel power indicator: 1 channels, dual colour LED Overheat indicator: Yellow LED
Operating Temperature	0 to +40°C
Finish	Panel: Surface-treated steel plate, black (30% gloss), paint
Dimensions	482 (w) x 88.4 (h) x 340.5 (d) mm
Weight	8.1 kg

Note: The design and specifications are subject to change without notice for improvement.

• Accessories

Rack mounting screw (5 x 12)	4
Fiber washer	4

16.8. VP-200VX Power Amplifier Input Module

Power Source	Supplied from VP-2241
Current Consumption	30 mA or less
Power Amplifier Link	RJ45 female connector for connecting the VX-200SP Twisted-pair straight cable (TIA/EIA-568A standard)
Finish	Panel: Surface-treated steel plate
Dimensions	88 (w) x 25.8 (h) x 53.2 (d) mm
Weight	50 g
Applicable Model	VP-2241

Note: The design and specifications are subject to change without notice for improvement.

16.9. WB-RM200 WALL MOUNTING BRACKET

Finish	Surface-treated steel plate, black, paint
Weight	100 g
Set Composition	Mount bracket ... 1
Accessory	Rack mounting screw ... 1 set
Usable Unit	RM-200M, RM-210

Note: The design and specifications are subject to change without notice for improvement.

